

E2 External Moisture

Acceptable Solution E2/AS1

**External moisture provisions for
timber-framed buildings up to 10 m in
height**

FOURTH EDITION | EFFECTIVE 28 JULY 2025



Preface

Preface

Document status

This document (E2/AS1) is an acceptable solution issued under section 22 (1) of the Building Act 2004 and is effective on 28 July 2025. It does not apply to building consent applications submitted before 28 July 2025. The previous Acceptable Solution E2/AS1 Third Edition, as amended, can be used to show compliance until 31 July 2026 and can be used for building consent applications submitted before 1 August 2026.

Building Code regulatory system

Each acceptable solution outlines the provisions of the Building Code that it relates to. Complying with an acceptable solution or verification method are ways of complying with that part of the Building Code. Other options for establishing compliance are listed in [section 19 of the Building Act](#).

Schematic of the Building Code system

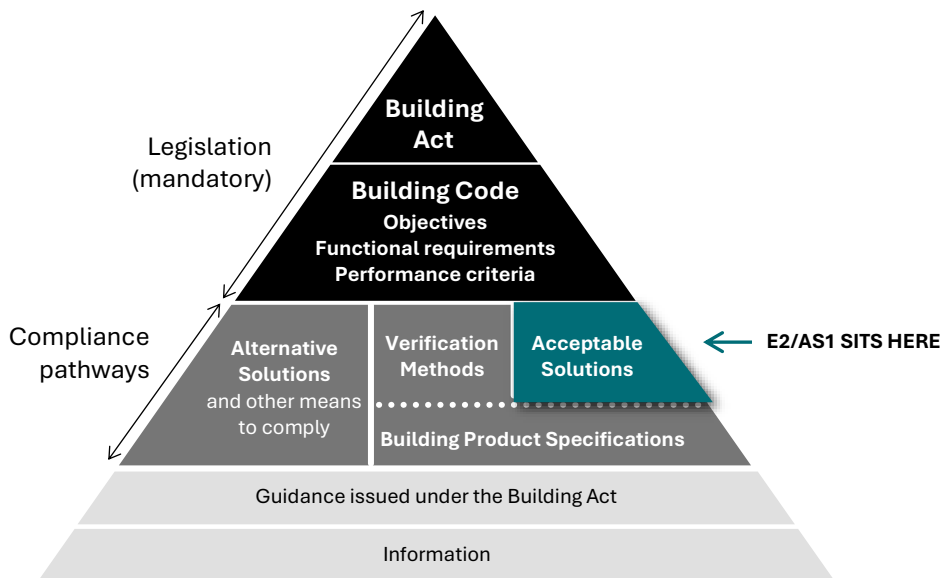

A building design must take into account all parts of the Building Code. The Building Code is located in Schedule 1 of the Building Regulations 1992 and available online at www.legislation.govt.nz.

The part of the Building Code that this acceptable solution relates to is clause E2 External Moisture. Information on the scope of this document is provided in [Part 1. General](#).

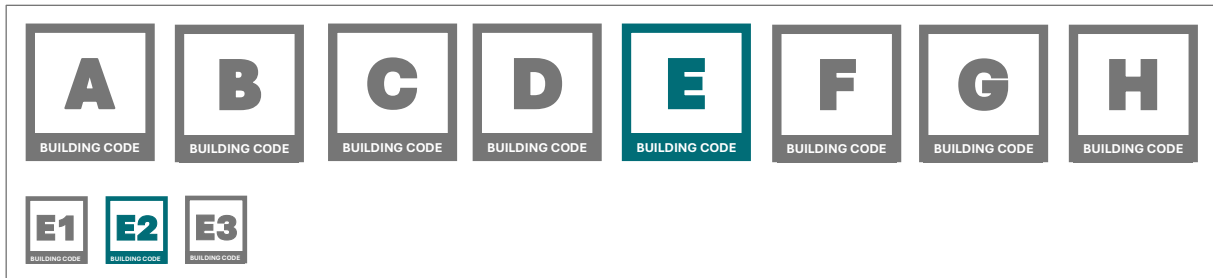

Further information about the Building Code, including objectives, functional requirements, performance criteria, acceptable solutions, and verification methods, is available at www.building.govt.nz.

Main changes in this version

Main changes in this version

This acceptable solution is the fourth edition of E2/AS1. The main changes from the previous version are:

- The document has been published in a standalone format and the layout has been revised to improve clarity. This includes using a common structure for headings, paragraph text, table numberings, and figure numbering throughout the acceptable solution.
- Cross-references to headings, paragraphs, tables, and figures have been revised to reflect the revised structure of the document.
- Minor amendments have been made to correct typos, grammar, cross-references, punctuation, wording, and formatting of the document. This includes changes to headings, paragraphs, tables and figures, table and figure notes, and definitions. These amendments do not affect the level of performance required in the document but may assist in the interpretation of the requirements.
- A title has been provided to the document to reflect the general scope of the acceptable solution. Additional information on the document and its scope has been provided in [Part 1. General](#).
- The acceptable solution now refers to the Building Product Specifications for the specification of windows and doors in Paragraph [9.1.9.2](#); fibre cement in Paragraphs [9.3.5.4](#), [9.5.2.1](#), [9.7.2.1](#); fibreglass reinforcing mesh and EIFS in Paragraphs [9.9.2.3](#) and [9.9.5.1](#). As a consequence, references to NZS 4211, EIMA 101.91, ASTM E2098, and ASTM E2134 have been removed from the document with the applicable specifications for these products located within the Building Product Specifications.
- References have been revised to reflect the documents cited in this acceptable solution in [Appendix A](#).
- Definitions have been revised to reflect the terms used in this acceptable solution in [Appendix B](#).
- Tables for the selection of materials, compatibility of materials, properties of underlays, and fixings have been relocated to [Appendix C](#).
- Examples for using the risk matrix have been relocated to [Appendix D](#).

People using this document should check for amendments on a regular basis. The Ministry of Business, Innovation and Employment may amend any part of any acceptable solution or verification method at any time. Up-to-date versions of acceptable solutions or verification methods are available from www.building.govt.nz.

Features of this document

Features of this document

- For the purposes of Building Code compliance, the standards and documents referenced in this acceptable solution must be the editions, along with their specific amendments, listed in [Appendix A](#).
- Words in *italic* are defined at the end of this document in [Appendix B](#).
- Hyperlinks are provided to cross-references within this document and to external websites and appear with a [blue underline](#).
- Appendices to this acceptable solution are part of, and have equal status to, the acceptable solution. Text boxes headed 'COMMENT' occur throughout this document and are for guidance purposes only.
- A consistent number system has been used throughout this document. The first number indicates the Part of the document, the second indicates the Section in the Part, the third is the Subsection, and the fourth is the Paragraph. This structure is illustrated as follows:

2	Part
2.5	Section
2.5.3	Subsection
2.5.3.1	Paragraph
2.5.3.1(a)	Paragraph (as a portion of the relevant paragraph)
2.5.3.1(a)(i)	Paragraph (as a portion of the relevant paragraph)

- Classified uses for *buildings*, as described in clause A1 of the Building Code, are printed in bold in this document. These requirements are also denoted with classified use icons.

H Housing	Com Commercial	Out Outbuildings
CR Communal residential	Ind Industrial	Anc Ancillary
CN Communal non-residential		

Contents

Contents

PART 1. GENERAL.....	7
1.1 Introduction	7
1.2 Using this acceptable solution	8
PART 2. CLADDING SYSTEMS AND MATERIALS	10
2.1 Cladding systems	10
2.2 Maintenance	10
PART 3. WEATHERTIGHTNESS RISK FACTORS.....	12
3.1 Establishing the risk.....	12
PART 4. FLASHINGS	17
4.1 Demonstrating compliance.....	17
4.2 Materials.....	17
4.3 Fixings	19
4.4 Flashing requirements	20
4.5 Flashing overlaps and upstands	22
PART 5. ROOF-TO-WALL JUNCTIONS	27
5.1 Demonstrating compliance.....	27
PART 6. PARAPETS	30
6.1 Demonstrating compliance.....	30
6.2 Cappings	33
PART 7. DECKS AND PERGOLAS.....	37
7.1 Demonstrating compliance.....	37
7.2 Thresholds for decks	37
7.3 Attachment to building structure	38
7.4 Level thresholds	40
7.5 Enclosed balustrades	43
PART 8. ROOF CLADDINGS	45
8.1 Demonstrating compliance.....	45
8.2 Masonry tiles.....	50
8.3 Pressed metal tiles	56
8.4 Profiled metal roof cladding	60
8.5 Membrane roofs and decks	76
PART 9. WALL CLADDINGS	87
9.1 Demonstrating compliance.....	87
9.2 Masonry veneer	104
9.3 Stucco	115
9.4 Timber weatherboards.....	119
9.5 Fibre cement weatherboards	130
9.6 Profiled metal wall cladding	135

Contents

- 9.7 Fibre cement sheet 145
- 9.8 Plywood sheet 158
- 9.9 EIFS 161
- PART 10. CONSTRUCTION MOISTURE 169**
- 10.1 Managing construction moisture 169
- 10.2 Measuring moisture content 169
- APPENDIX A. REFERENCES 171**
- APPENDIX B. DEFINITIONS 175**
- APPENDIX C. MATERIAL TABLES 181**
- C.1 Materials 181
- C.2 Underlays and membranes 181
- C.3 Fixing selection 181
- APPENDIX D. EXAMPLES USING THE RISK MATRIX 190**
- D.1 Simple buildings – example 1 190
- D.2 Moderately complex buildings – example 2 191
- D.3 Complex buildings – example 3 194

General

Part 1. General

1.1 Introduction

1.1.1 Scope of this document

1.1.1.1 This acceptable solution covers external moisture provisions for timber-framed *buildings* within the scope of NZS 3604. It is limited to the materials, products and processes contained herein, and limited to *buildings*:

- a) up to 3 *storeys* with a height measured from lowest ground level adjacent to the *building* to the highest point of the roof (except for chimneys, aerials and the like) of 10 m or less; and
- b) with floor plan area limited only by seismic and structural *control joints*; and
- c) *external walls* that are vertical, and *roofs* that are 60° or less above the horizontal.

1.1.1.2 Where *buildings* are based on NZS 3604, but require specific engineering design input, the *framing* shall be of at least equivalent stiffness to the framing provisions of NZS 3604.

COMMENT: The floor plan limitations of NZS 3604 may be exceeded up to the point that *specific design* is required to accommodate seismic or wind movement. Beyond that point, *specific design* is required to demonstrate compliance with clause E2 of the Building Code.

Claddings also required to perform as bracing must comply with NZS 3604. Where a *drained cavity* is used, specific testing can be used to demonstrate that a *cladding* on *cavity battens* can provide the required bracing resistance.

1.1.1.3 Attached garages that are integral with the *weathertightness* envelope of the *building* are included within the scope of this acceptable solution (refer to Paragraphs [9.1.2.7](#) and [9.1.1.6](#)).

1.1.2 Items outside the scope of this document

1.1.2.1 *Buildings*, components, or junction details not included or shown in this document are outside the scope of this acceptable solution.

Out

1.1.2.2 **Outbuildings**, such as stand-alone garages and other structures that are unlined, are outside the scope of this acceptable solution.

COMMENT: Details contained in this acceptable solution can be used for outbuildings and unlined structures, but the requirements may be in excess of the minimum required by the Building Code.

This is particularly the case in regard to unlined and uninsulated *buildings*, where a *drained cavity* is unlikely to be necessary.

However, care must be taken, as some *weathertight* details depend on the presence of an internal *lining* to provide pressure equalisation behind the *cladding*.

1.1.2.3 *Buildings* with *drained cavities* and spread of flame requirements, as specified Building Code clause C Protection from fire, are outside the scope of this acceptable solution. Cavities in such circumstances must be specifically designed for both *weathertightness* and spread of flame.

COMMENT: Options could include the provision of a *fire* rated wall behind the battens, or breaking the cavity at each floor and providing a *cavity flashing* and *fire stop* at each level.

1.1.2.4 *Buildings* with *drained cavities* and acoustic requirements, as specified in Building Code clause G6 Airborne and impact sound, are outside the scope of this acceptable solution.

General

COMMENT: Cavities in such circumstances must be specifically designed for both *weathertightness* and acoustic performance.

- 1.1.2.5 *Specific design* for preventing the ingress of snow melt water is required when the open ground snow load S_g , as defined in NZS 3604, exceeds 1.0 kPa, and the roof is *constructed* in a way that is likely to cause a build-up of snow.

COMMENT: *Hidden gutters, parapets*, and skylights are examples of features within a *roof* design that are likely to cause a build-up of snow

1.1.3 Compliance pathway

- 1.1.3.1 This acceptable solution is one option that provides a means of demonstrating compliance with the functional requirements and performance criteria in Building Code clause E2 External Moisture. It can be used to demonstrate compliance with performance clauses:

- a) E2.3.1 for shedding water; and
- b) E2.3.2 for the penetration of water; and
- c) E2.3.3 for contact with or proximity to the ground; and
- d) E2.3.4 for suspended floors; and
- e) E2.3.5 for concealed spaces and cavities; and
- f) E.2.3.6 for *construction* moisture; and
- g) E2.3.7 for the due allowance for:
 - i) the consequences of failure, and
 - ii) the uncertainties in *construction*, and
 - iii) variations relating to the materials and the site.

- 1.1.3.2 If this acceptable solution cannot be followed in full, use an alternative means to demonstrate compliance.

1.2 Using this acceptable solution

1.2.1 Qualifications

- 1.2.1.1 Certain work relating to the design or *construction* of external moisture-management systems in residential *buildings* is Restricted Building Work as defined by regulations made under the Building Act 2004.
- 1.2.1.2 The Building Act 2004 requires that Restricted Building Work is carried out or supervised by Licensed Building Practitioners who are licenced in the relevant class for that work (or certain registered professionals who may be treated as if they were licenced). In limited circumstances, Restricted Building Work may be carried out by owner-builders.

COMMENT: An understanding of the proper methods of design and installation and the importance of the correct construction sequence is essential if a Building Code compliant building is to be achieved.

Further information on Restricted Building Work and on Licensed Building Practitioners is available on the websites www.lbp.govt.nz or www.building.govt.nz.

General

1.2.2 Content of this acceptable solution

1.2.2.1 The provisions of this acceptable solution are arranged as follows:

- a) cladding systems and materials in [Part 2. Cladding systems and materials](#); and
- b) determining acceptable *walls claddings* in [Part 3. Weathertightness risk factors](#); and
- c) *flashings* in [Part 4. Flashings](#); and
- d) *roof to wall junctions* in [Part 5. Roof-to-wall junctions](#); and
- e) *parapets* in [Part 6. Parapets](#); and
- f) *decks* and *pergolas* in [Part 7. Decks and pergolas](#); and
- g) *roofs* in [Part 8. Roof claddings](#); and
- h) *walls* in [Part 9. Wall claddings](#); and
- i) *construction moisture* in [Part 10. Construction moisture](#).

1.2.3 Building Product Specifications

1.2.3.1 This acceptable solution refers to the Building Product Specifications for *building* product standards and specifications in relation to their manufacture, fabrication, testing, quality control, physical properties, performance, installation, and/or maintenance

1.2.3.2 The Building Product Specifications cannot be used in isolation to demonstrate compliance with any requirement of the Building Code. To comply with E2/AS1, *building* products conforming to the Building Product Specifications must be used with the scope, limitations, and other applicable requirements set out in this acceptable solution.

Cladding systems and materials

Part 2. Cladding systems and materials

2.1 Cladding systems

2.1.1 Selection of materials

2.1.1.1 Materials used to construct the *building* envelope shall be:

- a) in accordance with the durability requirements of Building Code clause B2 Durability; and
- b) suitable for their end-use, location, and environment as shown in [Table C.1.1.1A](#); and
- c) compatible with adjoining materials as shown in [Table C.1.1.1B](#) and [Table C.1.1.1C](#).

2.1.2 Systems versus materials

2.1.2.1 All *building* products shall be considered as part of a system, even if the components of that system are provided from different sources. Materials used to *construct* the *building* envelope shall be designed as a complete *cladding system* rather than as separate items.

COMMENT:

1. It is important that the compatibility and durability of the combination of materials is able to be demonstrated for any given application.
2. Most manufacturers provide technical literature for their cladding materials and systems that include recommendations for design and installation. Manufacturers' recommendations may include information additional to that shown in this acceptable solution. However, some additional work, such as extra fixings that penetrate flashings, can lead to details that need to be considered in terms of specific design. Additional or alternative details may be required that need supporting documentation or testing to demonstrate compliance in regard to weathertightness.

2.1.3 Cladding finish colours

2.1.3.1 Finish colours for *flush-finished* fibre cement sheet and *EIFS* shall have a reflectivity of 40% or more when measured in accordance with ASTM C1549.

COMMENT: Dark colours cause *claddings* to reach higher temperatures, which results in more thermal expansion and a greater risk of cracking of joints in monolithic wall *claddings*. Risks of cracking are also associated with dark colours on painted timber wall *claddings* and trim. Expansion of metal roofing and *flashings* are affected by dark colours. Colour cards from some coating manufacturers may include reflectance values.

2.2 Maintenance

2.2.1 Maintenance to achieve durability

2.2.1.1 Maintenance shall be carried out as necessary to achieve the required durability of materials, components and junctions.

2.2.1.2 The extent and nature of necessary maintenance is dependent on the:

- a) type of *cladding* or components used; and
- b) position of *cladding* or components on the *building*; and
- c) geographical location of the *building*; and
- d) specific site conditions.

Cladding systems and materials

COMMENT: A deterioration in the appearance of the surface of a *cladding* does not necessarily relate to a deterioration in the *weathertightness* of the *cladding*.

2.2.2 Regular maintenance

2.2.2.1 Regular maintenance of a *building* will include:

- a) washing exterior surfaces; and
- b) inspecting surfaces and junctions, and repairing or replacing items when necessary, in order to preserve the *weathertightness* of the *building*; and
- c) maintaining clearances between *cladding* and external ground or paving as per Subsection 9.1.2; and
- d) maintaining minimum 35 mm clearances between *roofing* and *membrane* decking, and *wall cladding* above; and
- e) maintaining finish coatings especially for *stucco*, *EIFS*, and fibre cement *claddings*.

COMMENT: Washing by rain removes most accumulated atmospheric contaminants, but sheltered areas, such as walls directly below *eaves*, are protected from the direct effects of rain and require regular manual washing.

Some heavily textured surfaces will not be as effectively washed by rain as smoother surfaces, so will require more regular manual washing.

However, it is important that high pressure water is not directed at sensitive junctions such as window surrounds and other *flashings*. Great care must be taken to avoid water being driven past anti-capillary gaps and *flashings* into the *wall* cavities.

Weathertightness risk factors

Part 3. Weathertightness risk factors

3.1 Establishing the risk

3.1.1 Risk assessment

- 3.1.1.1 A risk assessment of the proposed design shall be carried out using a *building* envelope *risk matrix*. This allows the risks related to various features to be aggregated, resulting in a *risk score* for the design. [Figure 3.1.1.1](#) shows the process that shall be followed in order to assess the risk.

COMMENT: Analysis of inspection reports from leaking *buildings* shows that a high incidence of leaks is associated with junctions within, and penetrations through, the *building* envelope. It also shows serious problems are more commonly associated with *claddings* that have limited capacity to drain and dry out any water that gets behind them, when a leak occurs.

This acceptable solution addresses these problems in two ways:

1. By providing details for common junctions and penetrations of the *building* envelope; and
2. By classifying *buildings* within the scope of this document into risk categories, and requiring different *cladding* solutions depending on the *risk score*.

Using the risk assessment, risk factors can be identified and changes may be made to a design to lower the *risk score*.

3.1.2 Definitions of risk

- 3.1.2.1 [Table 3.1.2.1](#) sets out the definitions of risk levels relating to the location and design features of the *building*.

3.1.3 The risk score

- 3.1.3.1 [Table 3.1.3.1](#) sets out the *risk matrix* that shall be used to define the *risk score* for a *building* within the scope of this acceptable solution.
- 3.1.3.2 A *risk score* is calculated for each external face of the *building*. *Claddings* are then selected from [Table 3.1.3.2](#) according to the *risk scores*, or the highest *risk score* may be used for all *walls*.
- 3.1.3.3 Examples using the *risk matrix* are provided in [Appendix D. Examples using the risk matrix](#) for a range of *building* designs. The completion of the *risk matrix* for each design is shown, together with the choice of *wall claddings* the *risk scores* indicate.

COMMENT: The examples have been selected to show a range of design complexities, features and materials. Further guidance on using the risk matrix is available on www.building.govt.nz.

3.1.4 Wall cladding systems

- 3.1.4.1 *Wall cladding systems* in this acceptable solution include:
- a) *masonry veneer* in Section [9.2](#); and
 - b) *stucco* in Section [9.3](#); and
 - c) timber weatherboards in Section [9.4](#); and
 - d) fibre cement weatherboards in Section [9.5](#); and

Weathertightness risk factors

- e) profiled metal *wall claddings* in Section [9.6](#); and
- f) fibre cement sheet in Section [9.7](#); and
- g) plywood sheet in Section [9.8](#); and
- h) *EIFS* in Section [9.9](#).

3.1.4.2 Other *wall claddings* are outside the scope of this acceptable solution.

Figure 3.1.1.1: How to assess risk

Paragraph [3.1.1.1](#)

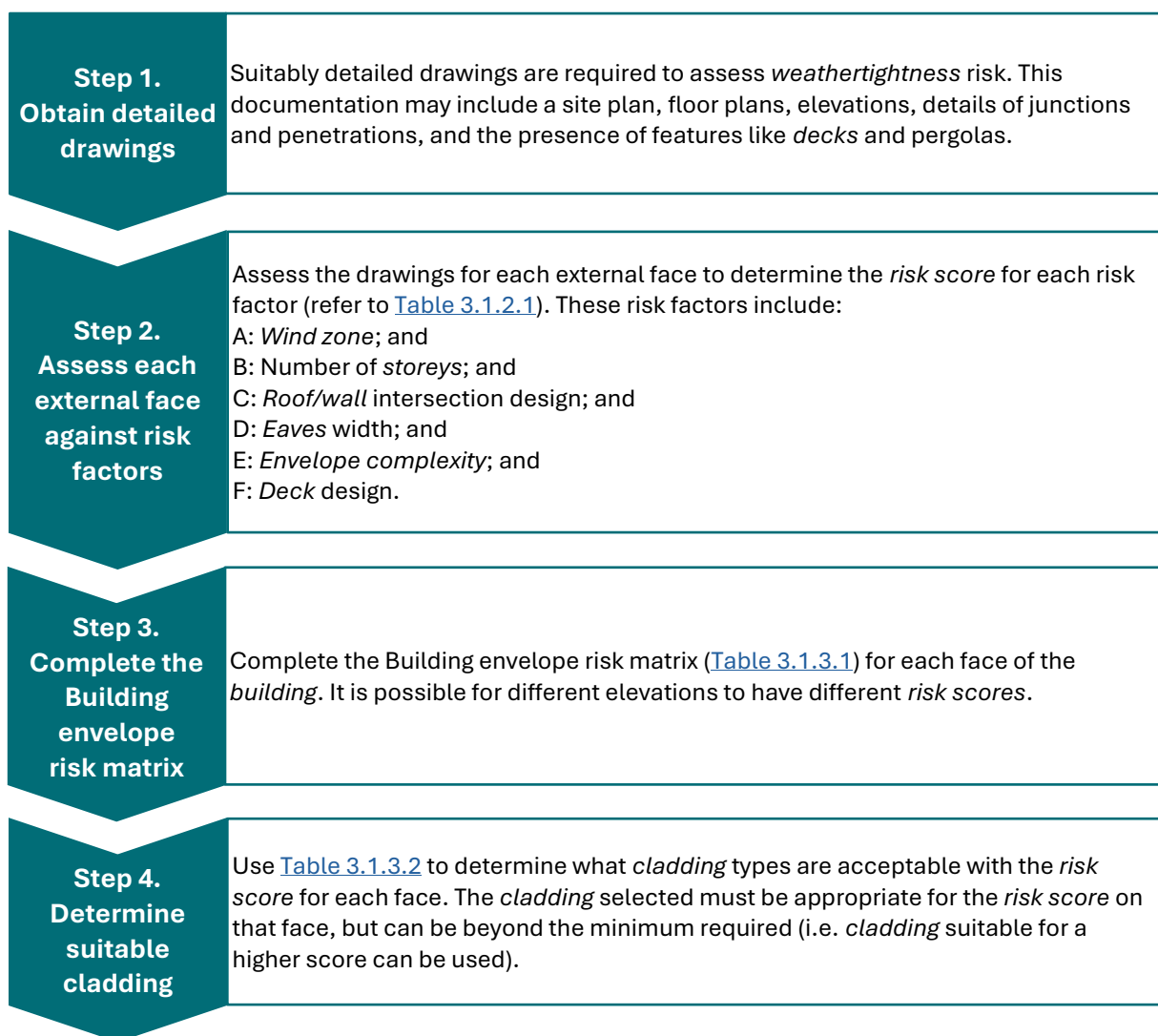

Weathertightness risk factors

Table 3.1.2.1: Definitions of risk levels

Paragraphs [3.1.2.1](#), [6.1.1.3](#), [7.5.1.1](#), [9.1.1.3](#), [9.1.6.2](#), [9.7.1.1](#), [Table 3.1.3.1](#), and [Figure 3.1.1.1](#)

Risk factor	Score ⁽⁵⁾	Risk severity	Comments
A: Wind zone	0	Low risk	Low <i>wind zone</i> as described by NZS 3604
	0	Medium risk	Medium <i>wind zone</i> as described by NZS 3604
	1	High risk	High <i>wind zone</i> as described by NZS 3604
	2	Very high risk	Very High <i>wind zone</i> as described by NZS 3604
	2	Extra high risk	Extra High <i>wind zone</i> as described by NZS 3604 ⁽⁴⁾
B: Number of storeys	0	Low risk	One <i>storey</i>
	1	Medium risk	Two <i>storeys</i> in part
	2	High risk	Two <i>storeys</i>
	4	Very high risk	More than two <i>storeys</i>
C: Roof/wall intersection design	0	Low risk	Roof-to-wall intersection fully protected (e.g. hip and gable roof with eaves)
	1	Medium risk	Roof-to-wall intersection partly exposed (e.g. hip and gable roof with no eaves)
	3	High risk	Roof-to-wall intersection fully exposed (e.g. <i>parapets</i> , <i>enclosed balustrades</i> , or <i>eaves</i> at greater than 90° to vertical with soffit <i>lining</i>)
	5	Very high risk	Roof elements finishing within the boundaries formed by the exterior walls (e.g. lower ends of aprons, <i>chimneys</i> , <i>dormers</i> , etc.)
D: Eaves width ⁽¹⁾⁽²⁾	0	Low risk	Greater than 600 mm for single <i>storey</i>
	1	Medium risk	451 to 600 mm for single <i>storey</i> , or over 600 mm for two <i>storeys</i>
	2	High risk	101 to 450 mm for single <i>storey</i> , or 451 to 600 mm for two <i>storeys</i> , or Greater than 600 mm above two <i>storeys</i>
	5	Very high risk	0 to 100 mm for single <i>storey</i> , or
			0 to 450 mm for two <i>storeys</i> , or 0 to 600 mm above two <i>storeys</i>
E: Envelope complexity	0	Low risk	Simple rectangular, L, T, or boomerang shape with single <i>cladding type</i>
	1	Medium risk	Moderately complex, angular, or curved shapes (e.g. Y or arrowhead) with no more than two <i>cladding types</i>
	3	High risk	Complex, angular, or curved shapes (e.g. Y or arrowhead) with multiple <i>cladding types</i>
	6	Very high risk	As for High risk, but with junctions not covered in C or F of this table (e.g. box windows, pergolas, multi-storey re-entrant shapes, etc.)
F: Deck design ⁽³⁾	0	Low risk	None, timber slat <i>deck</i> or porch at ground floor level
	2	Medium risk	Fully covered in plan by <i>roof</i> , or timber slat deck attached at first or second floor level
	4	High risk	<i>Enclosed deck</i> exposed in plan or cantilevered at first floor level
	6	Very high risk	<i>Enclosed deck</i> exposed in plan or cantilevered at second floor level or above

Notes:

(1) *Eaves width* measured horizontally from external face of *wall cladding* to outer edge of overhang, including fascias and external gutters/spoutings.

(2) *Balustrades* and *parapets* count as 0 mm eaves.

(3) The term *deck* includes balconies, as described in [Appendix B. Definitions](#).

(4) *Buildings* in Extra High *wind zones* require rigid *underlays* and *drained cavities*, refer to [Table 3.1.3.2](#).

(5) Refer also to [Table 3.1.3.1](#).

Weathertightness risk factors

Table 3.1.3.1: Building envelope risk matrix

Paragraph 3.1.3.1, Table 3.1.2.1, Table 3.1.3.2, and Figure 3.1.1.1

Risk factor	Low risk		Medium risk		High risk		Very High risk		Subtotals for each risk factor ⁽¹⁾
	severity ⁽¹⁾	Score	Severity ⁽¹⁾	Score	severity ⁽¹⁾	Score	severity ⁽¹⁾	Score	
Wind zone (as per NZS 3604) ⁽¹⁾	0		0		1		2		
Number of storeys	0		1		2		4		
Roof/wall intersection design	0		1		3		5		
Eaves width	0		1		2		5		
Envelope complexity	0		1		3		6		
Deck design	0		2		4		6		
Total risk score for use in Table 3.1.3.2									

Notes:

(1) Enter the appropriate risk severity score for each risk factor in the score columns. Transfer these numbers across to the right-hand column. Finally, add up the numbers in the right-hand column to get the total *risk score*.

(2) For *buildings* in Extra High wind zones, refer to Table 3.1.2.1 and Table 3.1.3.2 for rigid *underlay* and *drained cavity* requirements.

Weathertightness risk factors

Table 3.1.3.2: Suitable wall claddings

Paragraphs [3.1.3.2](#), [9.6.1.1](#), [9.6.1.2](#), [9.6.1.3](#), [9.4.1.5](#), [9.4.1.6](#), [Table 3.1.2.1](#), [Table 3.1.3.1](#), and [Appendix D. Examples using the risk matrix](#)

Risk score from Table 3.1.3.1	Suitable wall claddings ⁽¹⁾ for direct fixed to framing ⁽²⁾	Suitable wall claddings ⁽¹⁾ over nominal 20 mm drained cavity ⁽²⁾
0 to 6	a) Timber weatherboards – all types b) Fibre cement weatherboards c) Vertical profiles metal – corrugated and symmetrical <i>trapezoidal</i> ⁽⁴⁾ d) Fibre cement sheet ⁽⁵⁾ – jointed finish e) Plywood sheet	a) <i>Masonry veneer</i> ⁽³⁾ b) <i>Stucco</i> c) Horizontal profiled metal ⁽⁴⁾ – corrugated and <i>trapezoidal</i> only d) Fibre cement sheet – <i>flush-finished</i> e) <i>EIFS</i>
7 to 12	a) Bevel-back timber weatherboards b) Vertical timber board and batten c) Vertical profiled metal – corrugated only ⁽⁴⁾⁽⁷⁾	a) <i>Masonry veneer</i> ⁽³⁾ b) <i>Stucco</i> c) Horizontal profiled metal ⁽⁴⁾ – corrugated and <i>trapezoidal</i> only d) Rusticated weatherboards e) Fibre cement weatherboard f) Fibre cement – flush and jointed finish g) Plywood sheet h) <i>EIFS</i>
13 to 20	Vertical profiled metal – corrugated only ⁽⁴⁾⁽⁷⁾	a) <i>Masonry veneer</i> ⁽³⁾ b) <i>Stucco</i> c) Horizontal profiled metal ⁽⁴⁾ – corrugated and <i>trapezoidal</i> only d) Rusticated weatherboards e) Fibre cement weatherboard f) Fibre cement – flush and jointed finish g) Plywood sheet h) <i>EIFS</i> i) Bevel-back timber weatherboards
Over 20	a) Redesign the <i>building</i> to achieve a lower score, or b) Use <i>specific design</i> ⁽⁸⁾	a) Redesign the <i>building</i> to achieve a lower score, or b) Use <i>specific design</i> ⁽⁸⁾

Notes:

(1) The wall claddings in this table are limited to those covered in this acceptable solution.

(2) *Claddings* on *parapets*, *enclosed balustrades*, and in Extra High *wind zones* shall be installed over *drained cavities*. See notes (6) and (7).

(3) Traditional *masonry veneer* as per SNZ HB 4236, with minimum 40 mm cavity.

(4) Refer to [Figure 8.4.3.1](#) for profiles.

(5) Except *stucco* over a fibre cement backing.

(6) *Claddings* in Extra High *wind zones* require rigid underlays – refer to Paragraphs [9.1.6.2](#), [9.1.6.3](#), and [9.1.6.4](#).

(7) Direct fix vertical corrugated steel is included as cavity construction.

(8) *Specific design* is outside the scope of this acceptable solution. It may involve measures such as the following:

- (a) the design may need changing to reduce the risk, and
- (b) the building consent authority may require more comprehensive details and documentation providing evidence of weathertightness, and
- (c) the building consent authority, designer, or owner may require more inspections, and
- (d) a third-party audit of the design may be required.

Flashings

Part 4. Flashings

4.1 Demonstrating compliance

4.1.1 Overview

4.1.1.1 This part contains requirements for *flashings* to be used at junctions and penetrations of the *cladding system*.

4.2 Materials

4.2.1 Selection of flashing materials

4.2.1.1 *Flashing* materials shall take into account the following factors:

- a) the requirements of Building Code clause B2 Durability; and
- b) the environment where the *building* is located; and
- c) the specific conditions of use; and
- d) consideration of the surrounding materials.

COMMENT: Generally, the durability requirements for *flashings* specified in B2 are:

1. 50 years, where *flashings* are completely hidden behind *claddings* such as *masonry veneer*, or not accessible; and
2. 15 years, where *flashings* are exposed, partially exposed, or accessible.

Two-part *flashings* allow replacement of the *flashing* without *cladding* alteration. An example of a two-part *flashing* is shown in [Figure 4.5.2.1](#).

4.2.1.2 *Flashing* materials shall be selected according to the relevant exposure conditions as defined in [Table C.1.1.1A](#) to minimise corrosion.

COMMENT: The exposure zone in which a *building* is located can affect the durability of *flashings*.

Exposure zones are defined in NZS 3604, based on the likely exposure to wind-driven sea-salt. Corrosion due to geothermal or corrosive industrial atmospheres, as defined in NZS 3604, require *specific design*.

Exposure zones are based on AS/NZS 2728. AS/NZS 2728 lists atmospheric classes derived from ISO 9223 for Australia and New Zealand.

4.2.1.3 Metals that are in contact in locations where they will become wet, or where water can flow over various materials onto certain metals, shall be selected in accordance with [Table C.1.1.1B](#) and [Table C.1.1.1C](#).

COMMENT: Undesirable effects can occur when some materials are in contact with each other. Examples are corrosion of metals, stress cracking of plastics and staining of glass.

4.2.1.4 Uncoated metals shall not be used where carbon deposits or chemical contaminants may accumulate.

COMMENT: Carbon deposits such as soot will cause accelerated corrosion of damp uncoated metal.

Flashings

- 4.2.1.5 [Table C.1.1.1A](#), [Table C.1.1.1B](#), and [Table C.1.1.1C](#) shall be used to assess suitability of *flashing* materials for the required durability.

COMMENT: Additional guidance on *flashing* materials can be found in the New Zealand Metal Roof and Wall Cladding Code of Practice.

4.2.2 uPVC flashings

- 4.2.2.1 uPVC *flashings* shall be a minimum of 0.75 mm thick.
- 4.2.2.2 uPVC *flashings* shall comply with the requirements of the following Clauses of AS/NZS 4256.2:
- clause 9.2 Impact resistance; and
 - clause 9.3 Tensile strength; and
 - clause 9.4 Colourfastness and impact resistance following ultraviolet light exposure.
- 4.2.2.3 Where uPVC *flashings* are exposed to the weather, they shall also comply with Section 8 of AS/NZS 4256.2.
- 4.2.2.4 uPVC *flashings* shall have a finish colour with a reflectance of 40% or more, as outlined in Subsection [2.1.3](#).

COMMENT: Manufacturers of uPVC *flashings* which have a proven performance in use may be able to show compliance with Building Code clause B2 Durability as detailed in B2/VM1.

4.2.3 Aluminium flashings

- 4.2.3.1 Aluminium *flashings* shall be a minimum thickness of 0.7 mm, and formed from 5000 series in accordance with AS/NZS 1734.

4.2.4 Galvanized steel flashings

- 4.2.4.1 Galvanized steel *flashings* shall:
- have a BMT of 0.55 mm minimum; and
 - be grade G550, or G300 for rolled or crimped *flashings*; and
 - be selected for corrosion protection according to the intended exposure zone as shown in [Table C.1.1.1A](#).

4.2.5 Aluminium-zinc-magnesium (combinations) coated steel flashings

- 4.2.5.1 Aluminium-zinc-magnesium coated steel shall:
- comply with AS 1397; and
 - have a *BMT* of 0.55 mm minimum; and
 - be grade G550, or G300 for curved or crimped *flashings*; and
 - be selected for corrosion protection according to the intended exposure zone as shown in [Table C.1.1.1A](#).

4.2.6 Stainless steel flashings

- 4.2.6.1 Stainless steel *flashings* shall be:
- minimum thickness of 0.45 mm; and
 - 304 or 316 stainless steel in accordance with Table 1 of ISO/TS 15510.

4.2.7 Copper flashings

- 4.2.7.1 Copper *flashings* shall be:

Flashings

- a) a minimum thickness of 0.5 mm; and
- b) in compliance with AS 1566; and
- c) alloy, designation C11000 or C12200.

4.2.8 Lead sheet flashings

4.2.8.1 Lead sheet *flashings* shall:

- a) comply with AS 1804; and
- b) have a minimum unit mass of 17 kg/m².

4.2.9 Zinc sheet flashings

4.2.9.1 Zinc sheet *flashings* shall only be used in accordance with [Table C.1.1.1A](#), [Table C.1.1.1B](#), and [Table C.1.1.1C](#).

4.2.9.2 Zinc sheet *flashings* shall be:

- a) a minimum thickness of 0.7 mm; and
- b) in compliance with BS EN 988.

4.2.10 Butyl rubber and EPDM flashings

4.2.10.1 Butyl rubber *flashings* shall only be used in accordance with [Table C.1.1.1A](#), [Table C.1.1.1B](#), and [Table C.1.1.1C](#).

4.2.10.2 Butyl rubber and *EPDM flashings* shall be a minimum thickness of 1.0 mm, and shall comply with the following parts of Table 1 in ASTM D6134:

- a) tensile strength; and
- b) elongation; and
- c) water absorption; and
- d) water vapour permeance; and
- e) heat aging followed by:
 - i) tensile strength, and
 - ii) elongation.

4.2.11 Bituminous flashings

4.2.11.1 Bituminous *flashings* shall only be used in accordance with [Table C.1.1.1A](#).

4.2.11.2 *Flashings* made from bitumen-impregnated material shall:

- a) comply with AS/NZS 2904; and
- b) be used only in fully concealed applications.

4.2.12 Flexible flashing tape

4.2.12.1 *Flexible flashing tape* shall comply with Parts 3.2 and 4 of ICBO Acceptance Criteria AC148, shall be compatible with adjacent *building wall underlay* or *roof underlay*, and be used only in fully concealed applications.

4.3 Fixings

4.3.1 Fixings of flashings

4.3.1.1 Fixings of metal *flashings* shall comply with [Table C.1.1.1A](#), [Table C.1.1.1B](#), and [Table C.1.1.1C](#).

4.3.1.2 Exposed *flashings* such as barge and ridge *flashings* are to be fixed along both edges.

COMMENT: Fixings that penetrate flashings should be avoided where possible.

Flashings

4.4 Flashing requirements

4.4.1 Flashing locations

4.4.1.1 *Flashings* are required to shed or divert water at sensitive areas of the *building cladding*. These include at:

- the *building* periphery, except where gutters are present; and
- changes of direction in *cladding* materials; and
- intersections between *cladding* materials or with other *buildings*; and
- roof* or *wall* penetrations, including windows, doors and other penetrations.

4.4.2 Expansion joints in flashings

4.4.2.1 All *flashings* shall have *expansion joints* where required in Subsection 4.4.4 to provide for thermal expansion.

4.4.3 Edge treatments for flashings

4.4.3.1 *Flashings* shall be to the dimensions shown throughout this acceptable solution.

4.4.3.2 Exposed bottom edges of *flashings* shall be folded to a *kick-out* or a *bird's beak* as shown in Figure 4.4.3.2.

4.4.3.3 For Low, Medium, High, and Very High *wind zones*; *flashing* upstands shall have either:

- a *hem* or *hook* to Figure 4.4.3.2, with upstand dimensions as shown throughout the document; or
- no *hooks* or *hems*, and *flashing* upstand dimensions increased by 25 mm beyond those shown.

4.4.3.4 For Extra High *wind zones*, *hooks* and *hems* shall be used, and *flashing* upstand dimensions increased by 25 mm beyond those shown in Table 4.5.1.1 or elsewhere in the document.

COMMENT: Refer to the New Zealand Metal Roof and Wall Cladding Code of Practice for further edge treatments.

Figure 4.4.3.2: Typical metal flashing edge treatments

Paragraphs 4.4.3.2, 4.4.3.3, 6.2.2.1, 7.5.5.2, and 9.6.5.2

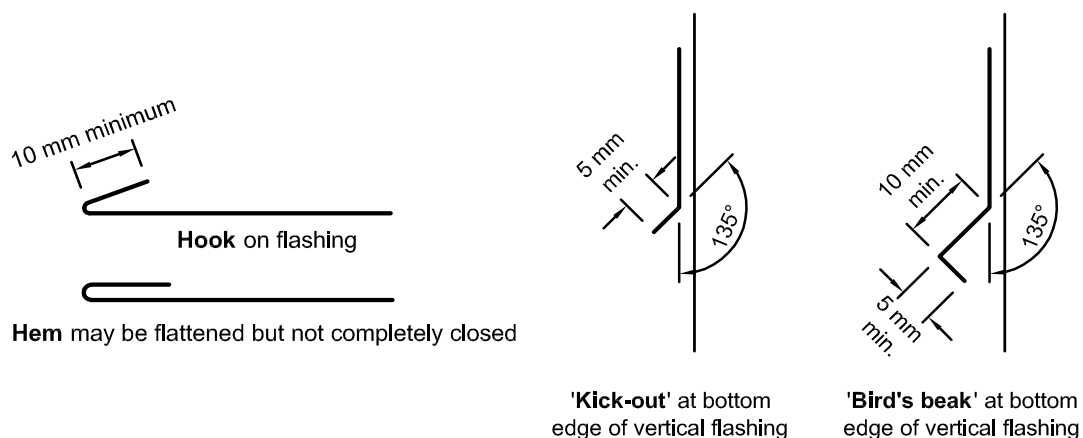

Notes:

(1) For L, M, H, VH *wind zones*, *hooks* and *hems* may be omitted on *flashing* upstands on condition the upstand dimensions are increased by 25 mm.

(2) For EH *wind zone*, *hems* and *hooks* are mandatory. Refer to Paragraph 4.4.3.4.

Flashings

4.4.4 Metal flashing joints

4.4.4.1 Where metal *flashings* require to be joined, the method shall be as shown in [Figure 4.4.4.1](#).

Joins of metal *flashings* shall have the following features:

- a) rivets used for joining and sealing laps shall be spaced at a maximum of 50 mm centres, and be:
 - i) compatible with the *flashing* material as per [Table C.1.1.1B](#) and [Table C.1.1.1C](#), and
 - ii) sealed against moisture, or
 - iii) of a sealing type or blind rivet; and
- b) *expansion joints* shall be provided for joined *flashings* with a combined length exceeding:
 - i) 12 metres for light coloured steel and stainless steel, and
 - ii) 8 metres for dark coloured steel, and
 - iii) 8 metres for copper, and
 - iv) 8 metres for aluminium; and
- c) where both ends of a *flashing* are constrained, allowance shall be made for expansion; and
- d) where necessary, *expansion joints* shall be formed as shown in [Figure 4.4.4.1](#), with:
 - i) minimum 200 mm laps, and
 - ii) sliding clips at both sides of the lap; and
- e) when using uncoated galvanized steel, zinc, stainless steel, or copper *flashings*, joints shall be riveted or soldered as described in the New Zealand Metal Roof and Wall Cladding Code of Practice; and
- f) when using uncoated or coated lead *flashings*, maximum continuous lengths shall be 1300 mm for 17 kg or 1500 mm for 20 kg lead and:
 - i) where the pitch of the *flashing* is greater than 15° at the join, the lap at the join shall be 100 mm minimum, and
 - ii) where the pitch of the *flashing* is 15° or less at the join, the lap at the join shall be 200 mm minimum and the *flashing* underneath the lap shall have a *hook* at the edge; and
- g) lap joints on other metal *flashings* shall be sealed using a neutral cure silicone sealant in conjunction with mechanical fasteners. The sealant shall comply with:
 - i) Type F, Class 20LM, or 25LM of ISO 11600, or
 - ii) low modulus Type II Class A of Federal Specification TT-S-00230C.

COMMENT: Further information may be found in the New Zealand Metal Roof and Wall Cladding Code of Practice for joints in metal *flashings*.

Flashings

Figure 4.4.4.1: Joints in metal flashings

Paragraph [4.4.4.1](#), [8.4.9.5](#), [8.4.9.6](#), and [9.6.5.3](#)

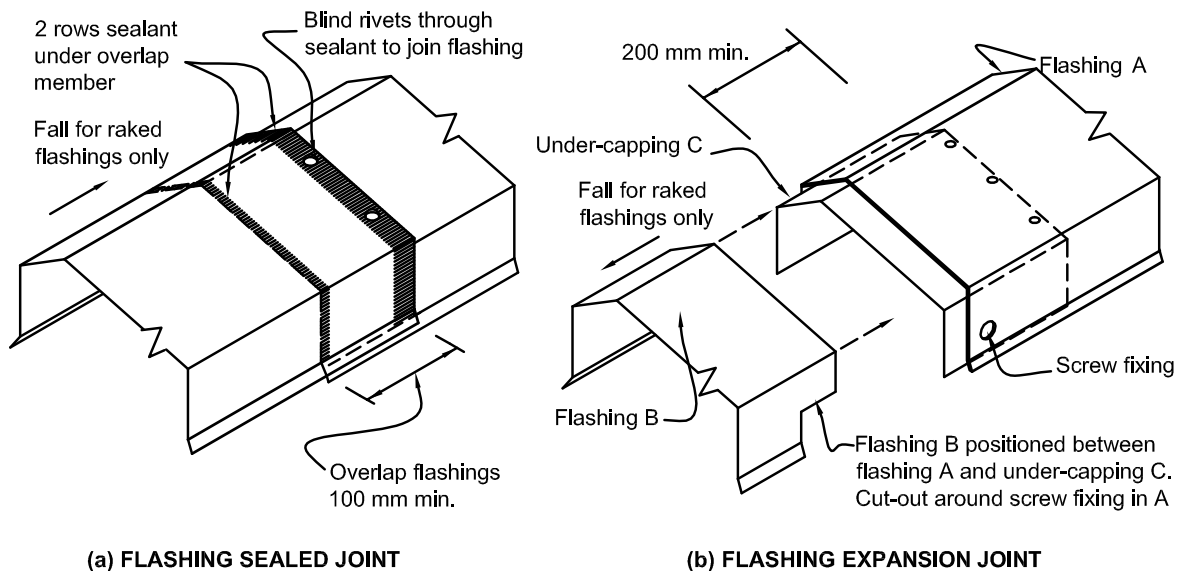

4.5 Flashing overlaps and upstands

4.5.1 Flashing edges

- 4.5.1.1 Overlaps and upstands to *flashings* shall be as specified in this subsection and [Table 4.5.1.1](#) unless specifically shown otherwise. For requirements for specific *claddings*, refer to [Part 8. Roof claddings](#) and [Part 9. Wall claddings](#)
- 4.5.1.2 *Flashing edges*, with *hooks*, *hems*, *kick-outs*, and *bird's beaks* shall be as required in [Table 4.5.1.1](#) and Subsection [4.4.3](#).
- 4.5.1.3 Where a turn-down to the cover *flashing* for profiled metal *claddings* is required, use:
- a *soft edge flashing* for corrugated profiles; or
 - a notched turn-down or *soft edge flashing* for *trapezoidal* profiles with rib height not exceeding 30 mm and/or rib centres not exceeding 200 mm; or
 - a notched turn-down for *trapezoidal* profiles with rib height exceeding 30 mm and/or rib centres exceeding 200 mm; or
 - a notched turn-down for *trough profiles*.
- 4.5.1.4 Where a notched turn-down is used there shall be a gap between the edge of the *flashing* and the pan of the *roof cladding*. The gap shall be a maximum of 5 mm.

Flashings

Table 4.5.1.1: General dimensions of metal flashings and other flashings as listed (continued on next page)

Paragraphs [4.4.3.4](#), [4.5.1.1](#), [4.5.1.2](#), [4.5.2.1](#), [4.5.3.1](#), [4.5.3.2](#), [4.5.4.1](#), [4.5.4.2](#), [4.5.5.1](#), [4.5.5.2](#), [5.1.2.2](#), [6.2.2.1](#), [6.2.4.1](#), [7.5.5.1](#), [8.3.2.5](#), [9.1.2.2](#), [9.1.9.8](#), [9.1.10.2](#), [9.4.5.6](#), [Figure 4.5.2.1](#), [Figure 6.1.1.4A](#), [Figure 6.1.1.4B](#), [Figure 7.5.6.1](#), [Figure 8.4.12.3B](#), [Figure 8.4.12.3C](#), [Figure 8.4.9.2A](#), [Figure 8.4.9.2B](#), [Figure 8.4.9.7A](#), [Figure 8.4.9.7B](#), [Figure 8.4.9.7C](#), [Figure 8.4.9.7D](#), [Figure 8.4.9.7E](#), [Figure 8.4.9.7F](#), [Figure 8.5.6.1C](#), [Figure 9.6.6.3](#), [Figure 9.6.6.9](#), and [Figure 9.9.9.4](#)

Type	Description	Minimum dimensions (1),(2),(3),(8)	Figure references (as examples)
Aprons: general	<i>Transverse flashing</i> over roofing	Situation 1: 130 mm ⁽⁴⁾ Situation 2: 200 mm ⁽⁴⁾ Situation 3: 200 mm ⁽⁴⁾	Figure 4.5.2.1 , Figure 8.4.9.7B , Figure 8.4.12.3B , Figure 8.4.12.3C (X values)
	<i>Parallel flashing</i> over roofing	All situations: Two crests, finish in next trough (refer to Paragraph 4.5.2.2(b))	Figure 8.4.9.7E , Figure 8.4.9.7F , Figure 8.4.12.3B (Y values)
Ridges/hips	<i>Transverse flashing</i> over roofing	Refer to Aprons: general	Figure 8.4.9.7A , Figure 8.4.9.7C(b) , Figure 8.4.9.7D
Changes in roof pitches	Upper lap under roofing	Situation 1 and 2: 250 mm Situation 3: Not permitted	Figure 8.4.9.7B
	<i>Transverse flashing</i> over roofing	Situation 1 and 2: Refer to Aprons: general Situation 3: Not permitted	
Barges	<i>Transverse flashing</i> over roofing	Situation 1: 50 mm ⁽⁷⁾ Situation 2: 70 mm ⁽⁷⁾ Situation 3: 90 mm ⁽⁷⁾	Figure 8.4.9.7E (Z values)
Cappings	Overlaps to <i>cladding</i>	Situation 1: 50 mm ⁽⁷⁾ Situation 2: 70 mm ⁽⁷⁾ Situation 3: 90 mm ⁽⁷⁾	Figure 6.1.1.4A (Z values)
	Slope to top: <i>parapet</i> and balustrade metal capping	All situations: 5°	Figure 6.1.1.4A , Figure 6.2.3.1A , Figure 6.2.3.1B , Figure 9.9.9.4
	Slope to balustrade: <i>flush-</i> <i>finished EIFS</i> and fibre cement ⁽⁵⁾	All situations: 10°	Figure 9.7.8.4 , Figure 9.9.9.3 , Figure 9.9.9.4
Roof or deck to wall (metal flashings)	Overlaps to roofing	Refer to Aprons: general	Figure 4.5.2.1 , Figure 8.2.5.1D , Figure 8.2.5.1H , Figure 8.3.6.1B , Figure 8.3.6.1D , Figure 8.4.9.7B , Figure 8.4.9.7F , Figure 8.4.11.2
	Lap under <i>cladding</i> above	Situation 1: 75 mm Situation 2: 75 mm Situation 3: 90 mm	

Flashings

Table 4.5.1.1: General dimensions of metal flashings and other flashings as listed (continued from previous page)

Type	Description	Minimum dimensions (1),(2),(3),(8)	Figure references (as examples)
Roof or deck to wall (metal flashings)	Clearance below <i>cladding</i>	All situations: 35 mm	
	Total upstand	Situation 1 and 2: 110 mm Situation 3: 125 mm	
Membrane roofs and decks	Lap under <i>cladding</i> above	All situations: 115 mm	Figure 7.5.4.1 , Figure 8.2.5.1H , Figure 8.5.4.1B , Figure 8.5.6.1D , Figure 8.5.8.1
	Window flange clearance for <i>direct fixed claddings</i> and ply or fibre cement on cavities	All situations: 5 mm	Figure 9.4.6.1A
Windows	Cover to window/door head and jamb flange	All situations: 10 mm ⁽⁷⁾	Figure 9.4.6.1A (a) and (c)
	Cover to window/door sill flange	All situations: 8 mm ⁽⁷⁾	Figure 9.4.6.1A(b)
	Sill flashing slope ⁽⁶⁾	All situations: Flat ⁽⁶⁾	Figure 9.1.9.4 , Figure 9.4.6.1A(b)
Heads	Head <i>flashing</i> slope	All situations: 15°	Figure 9.4.6.1A(a)
	Lap under <i>cladding</i> above	Situation 1 and 2: 35 mm Situation 3: 60 mm	Figure 9.4.6.1A(a)
	Anti-capillary gap to <i>cladding</i>	All situations: 5 mm (max. 10 mm)	Figure 9.4.6.1A(a)
	Total upstand	All situations: 40 mm	
Corners	Corner flashings	Situation 1 and 2: 50 x 50 mm Situation 3: 75 x 75 mm	Figure 9.4.4.5
	Inter-storey junctions (metal flashings)	Junction <i>flashing</i> slope	All situations: 15°
Lap over <i>cladding</i> below		Situation 1 and 2: 35 mm ⁽⁷⁾ Situation 3: 60 mm ⁽⁷⁾	Figure 9.1.8.4
Lap under <i>cladding</i> above		Situation 1 and 2: 35 mm Situation 3: 60 mm	Figure 9.1.8.4
Clearance under <i>cladding</i>		All situations: 5 mm (max. 10 mm)	Figure 9.1.8.4
Total upstand		All situations: 40 mm	Figure 9.1.8.4

Notes:

- (1) Situation 1: Low, Medium, and High *wind zones*; where the *roof pitch* $\geq 10^\circ$ (X or Z values).
(2) Situation 2: All *roof pitches* in Very High *wind zones*; or Low, Medium, and High *wind zones* where *roof pitch* $< 10^\circ$ (X or Z values).
(3) Situation 3: For all *roof pitches* in Extra High *wind zone*.
(4) Excludes any *soft edge* or turn-down to roofing.
(5) For *buildings* other than **housing**, the slope shall be as per Acceptable Solution F4/AS1.
(6) For *direct fixed* window/doors, unless shown. Sill *flashing* must extend past the condensation channel. Ensure sill *flashings* are not installed with backwards slope.
(7) Excludes *drip edge*.
(8) For edge treatments of flashings, refer to Subsection [4.4.3](#).

Flashings

4.5.2 Apron flashing cover to metal roofing

4.5.2.1 For an *apron flashing* cover over metal roofing with a *transverse flashing*, refer to [Figure 4.5.2.1](#) for example of use. The apron shall have:

- for notched turn-downs, a gap between the *flashing* and the pan of the *roof cladding*. The gap shall be a maximum of 5 mm; and
- a minimum effective cover to *roof cladding*, excluding any soft edge or turn-down to the flashing, as shown in [Table 4.5.1.1](#).

4.5.2.2 For an *apron flashing* cover over metal roofing with a *parallel flashing*, refer to [Figure 8.4.9.7F](#) for example of use. The apron shall:

- be dimensioned to suit the *roof cladding* profile; and
- for profiled metal *roof cladding*, cover at least two crests, (turned-up edge to full crest height constitutes a crest); and
- for profiled metal *roof cladding*, overhang *flashing* a minimum 10 mm clear of crest and maximum 5 mm clear of trough as shown in [Figure 8.4.9.7E](#).

Figure 4.5.2.1: Basic apron flashing

Paragraphs [4.5.2.1](#), [5.1.2.2](#), [Figure 4.5.2.1](#), and [Table 4.5.1.1](#)

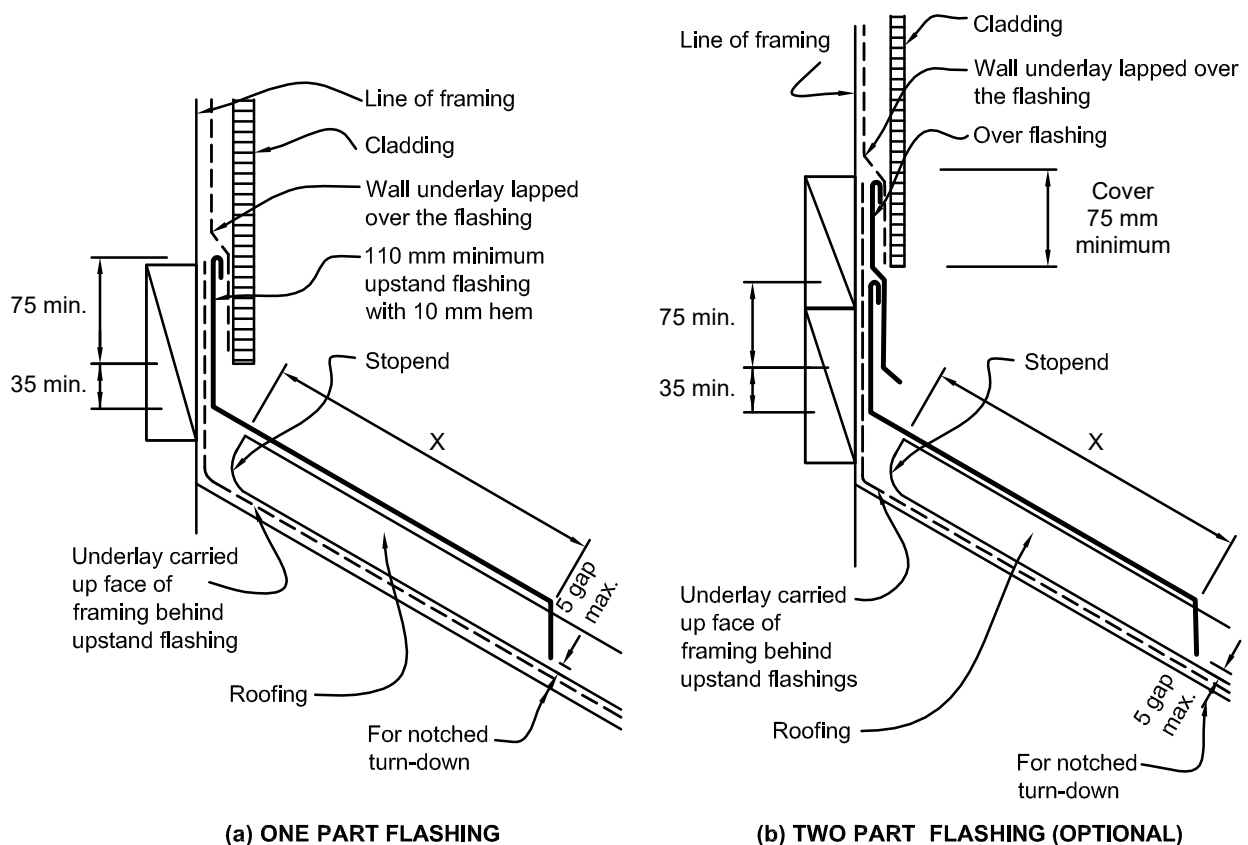

Notes:

- For *stopends* to profiled metal, refer to [Figure 8.4.10.1](#).
- For dimension X, refer to [Table 4.5.1.1](#).

Flashings

4.5.3 Roof-to-roof junction flashing cover for metal roofing

4.5.3.1 For ridges and hips, refer to [Figure 8.4.9.7D](#) for example of use and:

- a) for notched turn-downs of the *flashing* leave a gap between the *flashing* and the *roof cladding*. The gap shall be a maximum of 5 mm; and
- b) there shall be a minimum effective cover to *roof cladding*, excluding any soft edge or turn-down to the *flashing*, in accordance with [Table 4.5.1.1](#).

4.5.3.2 For a change in metal roof pitches, refer to [Figure 8.4.9.7B](#) for example of use and:

- a) there shall be a minimum effective lap under *roof cladding* in accordance with [Table 4.5.1.1](#), with a *hem* at upper edge; and
- b) the apron cover over the *roof cladding* shall be in accordance with [Table 4.5.1.1](#).

4.5.4 Roof edge junction flashing cover

4.5.4.1 For roof- or deck-to-wall junctions, refer to [Figure 4.5.2.1](#) for example of use. There shall be a total minimum upstand height of 110 mm, in accordance with [Table 4.5.1.1](#), comprising a minimum:

- a) overlap cover of cladding to the flashing upstand of 75 mm; and
- b) 35 mm clearance from bottom of the wall cladding to *roof cladding* or finished *deck* material.

4.5.4.2 For barges, refer to [Figure 8.4.9.7E](#) for example of use and:

- a) there shall be a minimum effective overlap to the barge board, excluding the drip edge to the *flashing*, in accordance with [Table 4.5.1.1](#); and
- b) the apron cover over the *roof cladding* shall be as for Paragraphs [4.5.2.1](#) and [4.5.2.2](#).

4.5.5 Window, door, and inter-storey junction flashings

4.5.5.1 For window and door heads, refer to [Figure 9.1.10.1](#) and [Figure 9.4.6.1A](#) for example of use and:

- a) slopes and covers of *flashings* at window and door heads shall comply with [Table 4.5.1.1](#); and
- b) overlap cover of *cladding* to the *flashing* upstand and clearance from the bottom of the cladding to top of head flashing slope shall be in accordance with [Table 4.5.1.1](#); and
- c) details for door heads shall be based on those applying to windows.

4.5.5.2 For inter-storey junctions, refer to Paragraph [9.1.8.4](#) and [Figure 9.1.8.4](#); and

- a) minimum slopes and covers of *flashings* shall be in accordance with [Table 4.5.1.1](#); and
- b) overlap cover of the *cladding* to the flashing upstand, and clearance from the bottom of the *cladding* to the top of the slope of the head *flashing*, shall be in accordance with [Table 4.5.1.1](#).

Roof-to-wall junctions

Part 5. Roof-to-wall junctions

5.1 Demonstrating compliance

5.1.1 Overview

5.1.1.1 This part contains provisions for *roof-to-wall* junctions for the *cladding system*.

5.1.2 Apron flashings

5.1.2.1 Refer to [Section 4.2](#) for acceptable *apron flashing* materials.

5.1.2.2 All *roof-to-wall* junctions shall be made *weathertight* by using an *apron flashing* as outlined in Paragraphs [4.5.2.1](#) and [4.5.2.2](#), and shown in [Figure 4.5.2.1](#), that:

- a) provides a minimum lap under the *wall cladding* of 75 mm in accordance with [Table 4.5.1.1](#), except that pressed metal tiles shall have a *flashing* fitted to achieve the minimum required overlap of *wall cladding*, as shown in [Figure 8.3.6.1B](#); and
- b) for profiled metal, incorporates *stopends* at the upper end of the *roof cladding* as per Subsection [8.4.10](#); and
- c) provides a minimum clearance from the *wall cladding* to the roofing in accordance with [Table 4.5.1.1](#); and
- d) extends over the roofing by a minimum cover in accordance with Paragraphs [4.5.2.1](#) and [4.5.2.2](#) and [Table 4.5.1.1](#) depending on the:
 - i) *wind zone* and,
 - ii) pitch of the *roof*.

COMMENT: 40 mm is the maximum upturn achievable with pressed metal tiles, meaning that a *flashing* is required.

5.1.2.3 Details for specific *wall cladding systems* are given in [Part 9. Wall claddings](#).

5.1.2.4 Where the *roof* finishes within the length of an adjacent *wall*, a *kick-out* or *stopend* as detailed in [Figure 5.1.2.4](#) shall be provided to direct water out from the *wall cladding* onto the *roof cladding* and gutter.

5.1.3 Gutters, barges, and fascias

5.1.3.1 Where *eaves gutters/spoutings*, *barges*, or *fascias* terminate against *claddings*, these shall be installed after the *wall cladding*, and after any protective finishes have been applied.

5.1.3.2 *Eaves gutters/spouting*, *barges*, and *fascias* shall terminate so as to leave a gap of 10 mm from the finished *wall cladding* as shown in [Figure 5.1.2.4](#).

COMMENT: It is important to ensure the *wall cladding* behind *eaves gutters/spoutings*, *barges* and *fascias* is protected by the surface coating to prevent moisture penetration through the unsealed *cladding*.

5.1.4 Soffits

5.1.4.1 *Eaves* shall be enclosed by installing soffit linings direct fixed to framing and comprising minimum 4.5 mm fibre cement sheet, or 7 mm H3 plywood, with joints, fixings, and finishes as shown in Sections [9.7](#) and [9.8](#).

5.1.4.2 Soffit *linings* shall be finished to *fascias*, *barges*, and *wall claddings* as outlined in

- a) [Figure 5.1.4.2](#) generally; or
- b) [Figure 9.7.6.1](#) for *flush-finished* fibre cement.

Roof-to-wall junctions

5.1.4.3 *Wall underlays* shall not be required behind soffit *linings*.

Figure 5.1.2.4: Gutter/wall junction

Paragraphs [5.1.2.4](#) and [5.1.3.2](#)

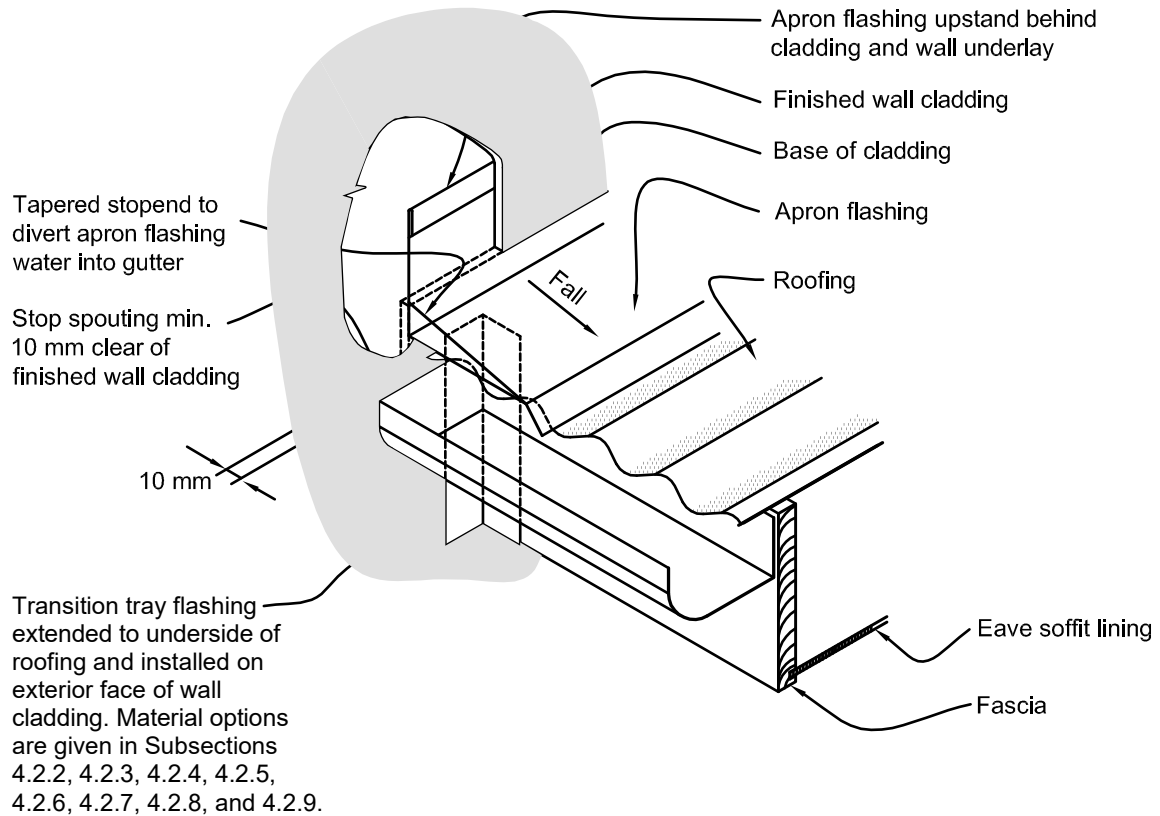

Notes:

- (1) The upstand at the lower edge of the *apron flashing* may be preformed to a larger size and then trimmed on site to suit.
- (2) The transition *flashing* bridges gap at the end of the fascia to protect the soffit *framing*.
- (3) *Wall underlay* not shown for clarity.

Roof-to-wall junctions

Figure 5.1.4.2: Soffit/wall junction

Paragraphs 5.1.4.2, 9.7.6.1, and 9.8.6.1

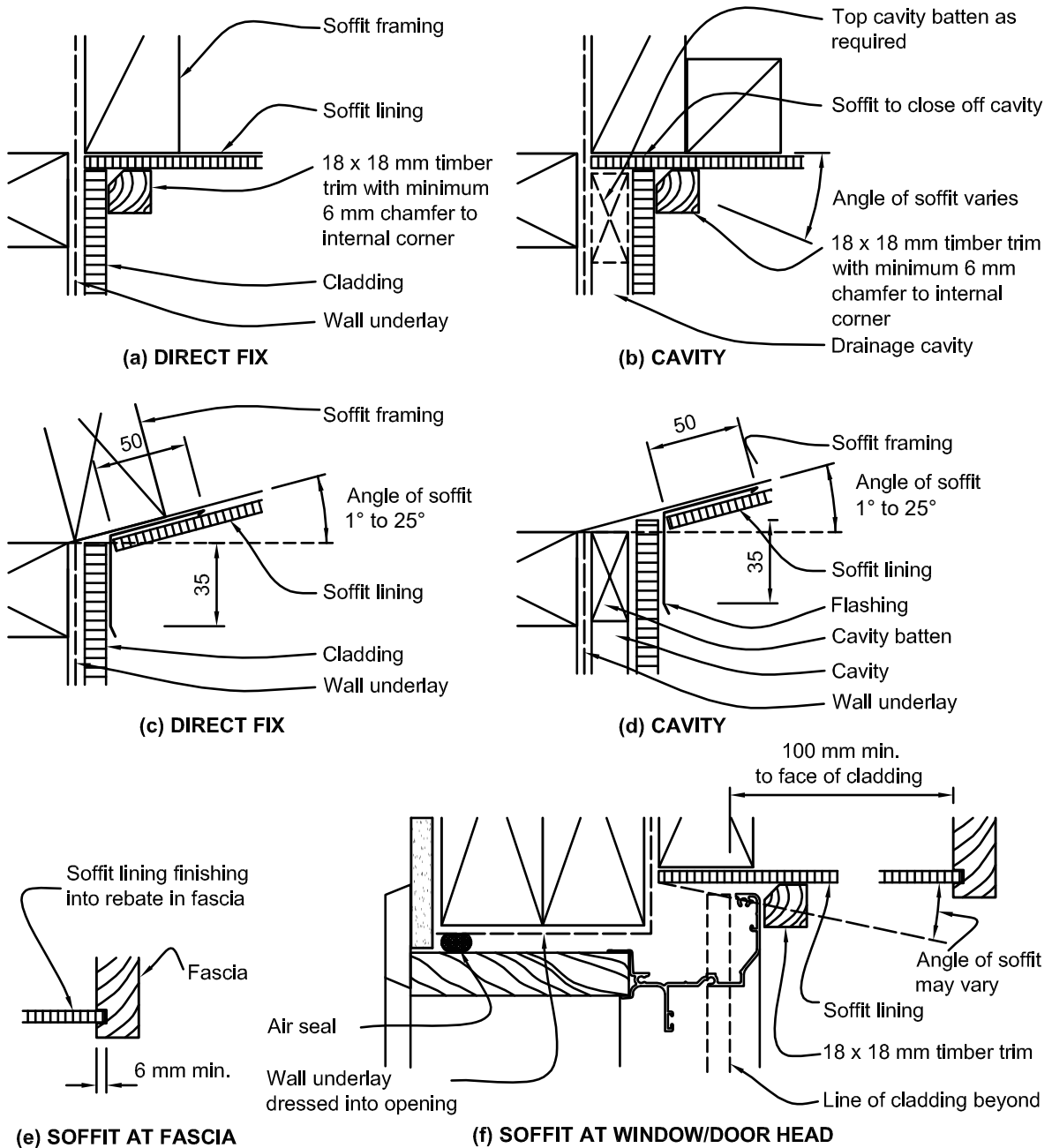

Parapets

Part 6. Parapets

6.1 Demonstrating compliance

6.1.1 Overview

- 6.1.1.1 This part contains provisions for *cladding systems* used for *parapets*.
- 6.1.1.2 This acceptable solution does not cover *parapet* cappings that use *stucco*, *EIFS*, and *flush-finished* fibre cement materials.
- 6.1.1.3 *Claddings* on *parapets* shall be installed over a *drained cavity* except for vertical corrugated steel as outlined in [Table 3.1.2.1](#). Refer also to Section [7.5](#).
- 6.1.1.4 *Parapets* shall be *constructed* as shown in [Figure 6.1.1.4A](#), and shall comply with the following requirements:
 - a) timber for *framing* and *cavity battens* shall comply with B2/AS1; and
 - b) sloped packers under cappings shall be polystyrene or timber treated to B2/AS1, or minimum 9 mm H3 plywood on packers; and
 - c) *framing* shall be fully enclosed with *wall underlay* or *roof underlay*, in accordance with [Table C.2.1.1](#) for the specific *cladding*; and
 - d) *claddings* shall be installed over a *drained cavity* in accordance with Subsection [9.1.7](#).
- 6.1.1.5 Details for specific wall cladding systems are given in [Part 9. Wall claddings](#).
- 6.1.1.6 Specific requirements for enclosed balustrades are given in Section [7.5](#).

Parapets

Figure 6.1.1.4A: General construction of parapet and enclosed balustrade

Paragraph [6.1.1.4](#), [6.2.2.1](#), [7.5.1.1](#), [Figure 6.1.1.4A](#), [Figure 6.1.1.4B](#), and [Table 4.5.1.1](#)

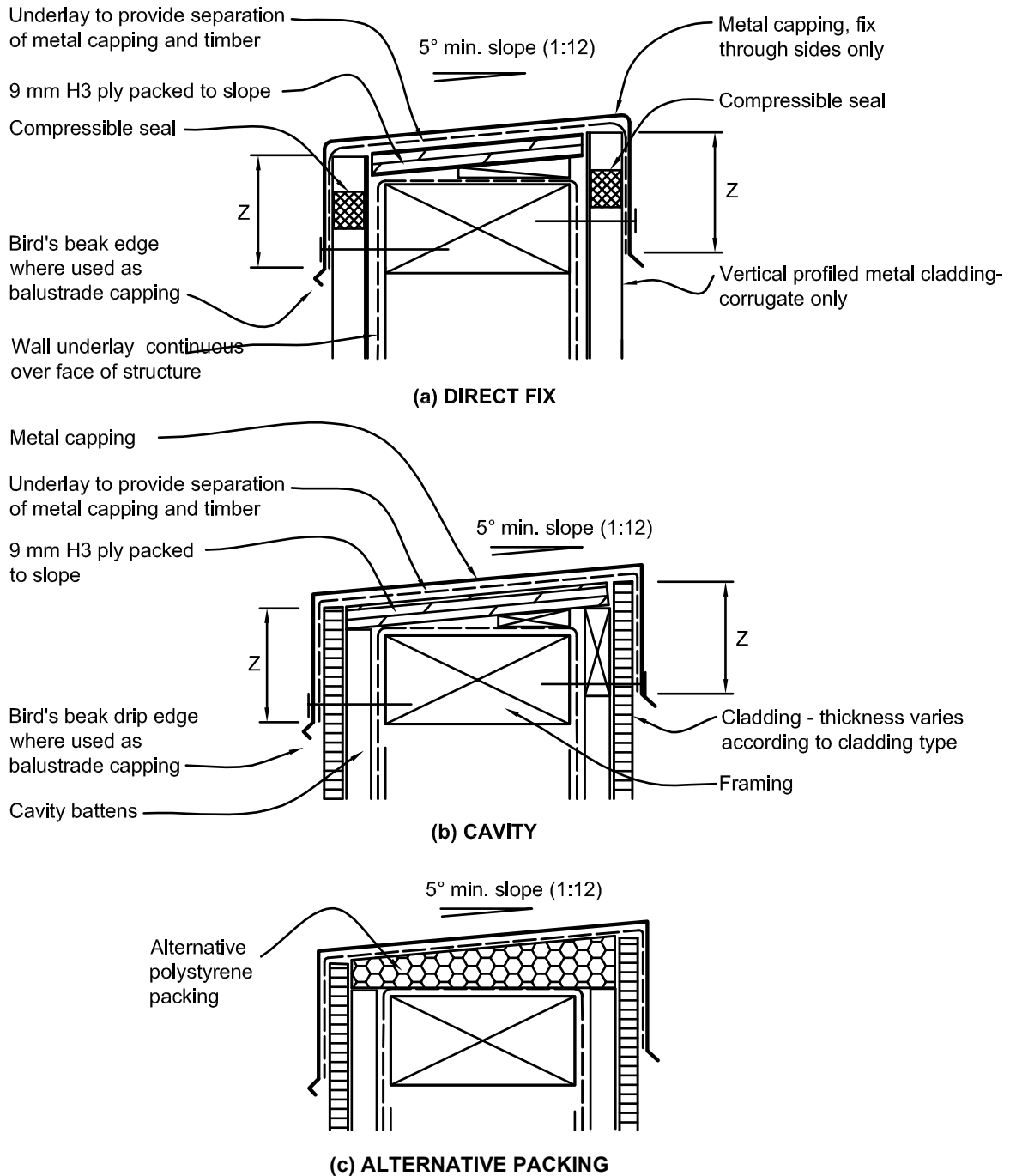

Notes:

- (1) For *capping* joints and fixings, refer to Subsection [4.4.4](#).
- (2) For dimension Z, refer to [Table 4.5.1.1](#)

Parapets

Figure 6.1.1.4B: General capping joints for parapets and enclosed balustrades

Paragraph 6.1.1.4 and 6.2.2.1

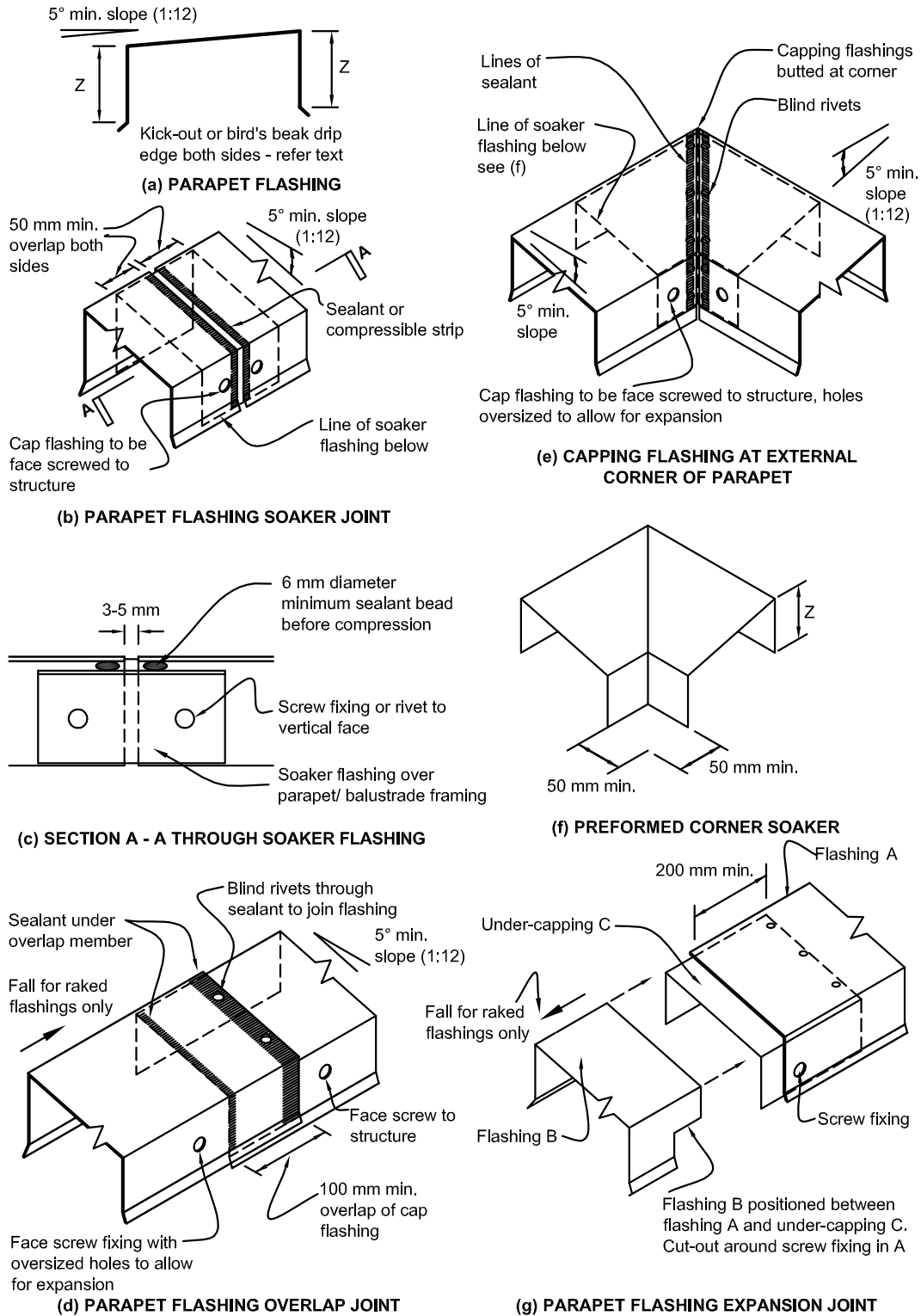

Notes: (1) For dimension Z, refer to [Table 4.5.1.1](#)

(2) For capping joints and fixings, refer to Subsection [4.4.4](#) and [Figure 6.1.1.4A](#).

Parapets

6.2 Cappings

6.2.1 Capping materials

6.2.1.1 *Parapets* shall be capped with metal, butyl membrane, or EPDM membrane. *Cappings* shall comply with the requirements of [Part 4. Flashings](#).

6.2.2 Metal cappings

6.2.2.1 Metal *cappings* installed over *parapets* and *enclosed balustrades*, shall be as outlined in this part and [Section 7.5](#), and comply with the following requirements:

- a) tops of *cappings* shall be free of any penetrations; and
- b) slope of top shall be 5° (1:12) minimum; and
- c) the cover at the sides of the *capping* shall be in accordance with [Table 4.5.1.1](#); and
- d) all *cappings* shall have *drip edges*. The details shown in [Figure 4.4.3.2](#) are acceptable minimum *drip edges* for *parapets*; and
- e) *cappings* shall be separated from underlying timber by *roof underlay* as shown in [Figure 6.1.1.4A](#); and
- f) lengths of *capping* shall be joined as shown in [Figure 6.1.1.4B\(b\)](#) or [Figure 6.1.1.4B\(d\)](#); and
- g) external corners of *cappings* shall be as shown in [Figure 6.1.1.4B\(e\)](#); and
- h) Expansion joints shall be provided for joined *cappings* with a combined length exceeding:
 - i) 12 metres for light coloured steel and stainless steel, 8 metres for dark coloured steel, and
 - ii) 8 metres for copper, and
 - iii) 8 metres for aluminium; and
- i) where both ends of a *capping* are constrained, allowance shall be made for expansion; and
- j) where necessary, expansion joints shall be formed as shown in [Figure 6.1.1.4B\(g\)](#), and with:
 - i) minimum 200 mm laps; and
 - ii) sliding clips at both sides of the lap.

6.2.2.2 Any textured coating application, except for the finished coat, over *flush-finished cladding* shall be completed prior to the installation of metal *cappings*.

6.2.3 Parapet-to-wall junctions with metal cappings

6.2.3.1 Junctions of *parapets* to *walls* shall be flashed to direct water clear of the outside face of the *cladding system*, using a saddle *flashing* as shown in [Figure 6.2.3.1A](#) and [Figure 6.2.3.1B](#).

COMMENT: Reports on leaky *buildings* show these junctions have been prone to leakage and care must be taken to detail and build them correctly.

6.2.3.2 *Parapets* that are continuous and in-plane with adjacent wall surfaces are outside the scope of this acceptable solution. An offset in wall line between *parapet* and adjacent *wall* is required as in [Figure 6.2.3.1A](#) and [Figure 6.2.3.1B](#).

COMMENT: In-plane junctions require *specific design* of *flashing* arrangements.

Parapets

6.2.4 Membrane cappings

6.2.4.1 Butyl rubber and *EPDM cappings* shall be in accordance with Subsection [4.2.10](#), and comply with the following requirements:

- tops of *membrane cappings* shall be free of any penetrations, and shall have a minimum slope of 10° (1:6); and
- sides of *membrane cappings* shall overlap the *wall claddings* as outlined in [Table 4.5.1.1](#); and
- joints shall be in accordance with Paragraphs [8.5.3.3](#) and [8.5.3.4](#).

6.2.5 Integral surface cappings

6.2.5.1 *Cappings* formed by using *EIFS* or *flush-finished* fibre cement materials shall not be used for *parapets* but may be used for *enclosed balustrades* as described in Section [7.5](#).

COMMENT: The tops to *parapets* are considered to be more risky locations than the tops to *enclosed balustrades*, as they are less accessible for inspection and regular maintenance.

Figure 6.2.3.1A: Parapet/enclosed balustrade-to-wall junctions – plan section

Paragraph [6.2.3.1](#), [6.2.3.2](#), [7.5.1.1](#), [7.5.3.1](#), [9.9.9.5](#), [Figure 6.2.3.1B](#), [Figure 9.7.8.4](#), [Figure 9.9.9.3](#), and [Table 4.5.1.1](#)

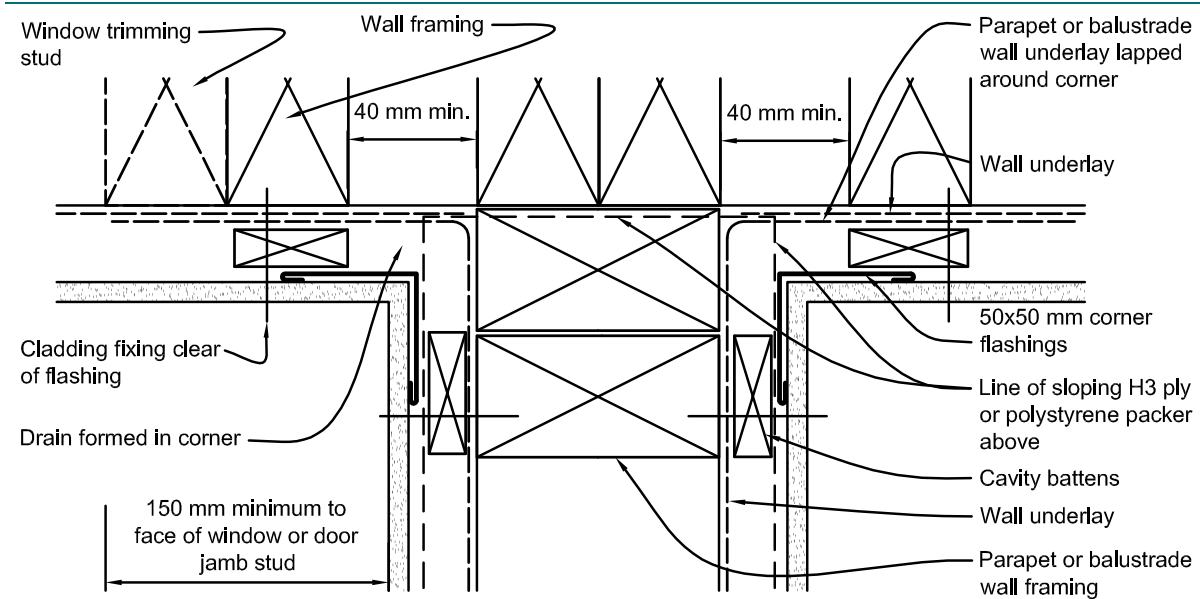

Notes:

- (1) For *saddle flashing* and *capping-to-wall* junction, refer to [Figure 6.2.3.1B](#).
- (2) Plan section is through balustrade or *parapet framing* below *capping* packer.

Parapets

Figure 6.2.3.1B: General junction of parapet and enclosed balustrade-to-wall with metal capping (figure notes on next page)

Paragraph [6.2.3.1](#), [6.2.3.2](#), [7.5.1.1](#), [7.5.3.1](#), [9.9.9.5](#), [Figure 6.2.3.1A](#), [Figure 9.7.8.4](#), [Figure 9.9.9.3](#), and [Table 4.5.1.1](#)

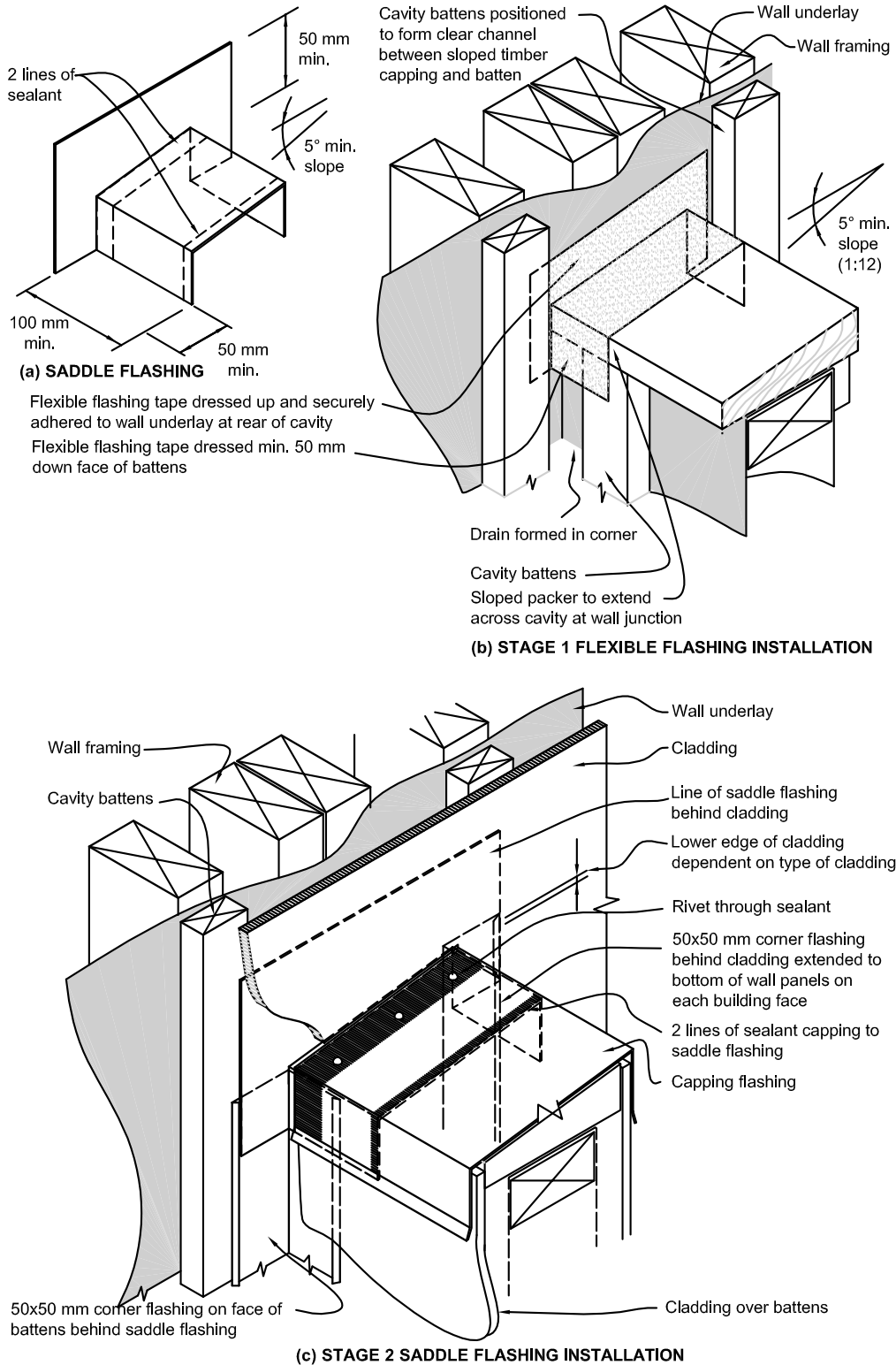

Parapets

Notes:

- (1) The junction is weatherproofed by the *saddle flashing* which is positioned at the front of the cavity as shown in (c).
- (2) The *flexible flashing tape* over the sloped *capping* packer is intended to:
 - (a) drain only moisture from within the drained cavity above; and
 - (b) to direct it into the adjacent continuous cavity.For the plan section, refer to [Figure 6.2.3.1A](#).
- (3) Separation layer of *underlay* between sloped timber *capping* and *capping flashing* not shown for clarity.

Decks and pergolas

Part 7. Decks and pergolas

7.1 Demonstrating compliance

7.1.1 Overview

- 7.1.1.1 This part contains provisions for *cladding systems* for or connected with *decks* and *pergolas*.
- 7.1.1.2 Enclosed *decks* shall have a maximum area of 40 m².
- 7.1.1.3 Junctions between *wall claddings* and the surface of enclosed *decks* shall be as shown in [Figure 8.5.6.1D](#).

7.1.2 Materials

- 7.1.2.1 Timber used to construct *decks*, *enclosed balustrades*, and other attachments such as *pergolas* shall comply with B2/AS1.

7.2 Thresholds for decks

7.2.1 Threshold height above deck surface

- 7.2.1.1 The vertical separation between the opening threshold level and the upper surface of the deck shall be as shown in [Figure 7.2.1.1](#).
- 7.2.1.2 Opening threshold level may be at or above floor level.

Figure 7.2.1.1: Threshold separation

Paragraphs [7.2.1.1](#) and [7.2.2.1](#)

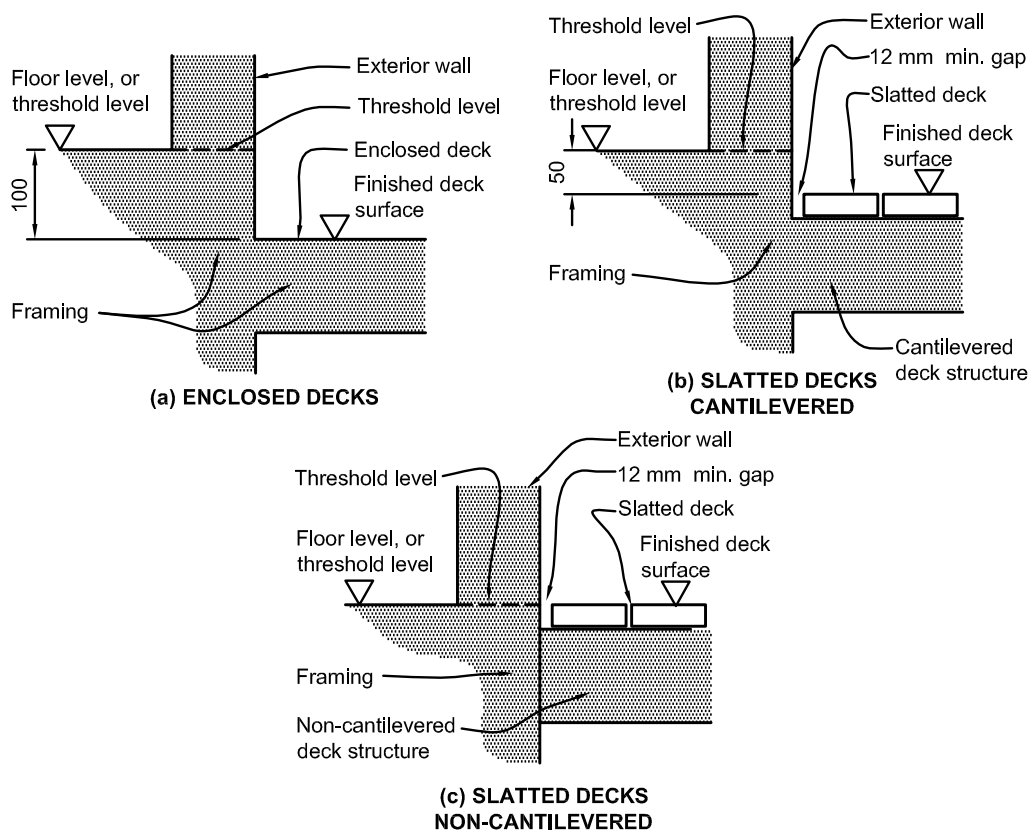

Note: (1) Threshold level may be above the floor level.

Decks and pergolas

7.2.2 Thresholds of slatted decks

7.2.2.1 The level of the upper surface of the slatted *deck*:

- shall be a minimum of 50 mm below the threshold level for *cantilevered decks* as shown in [Figure 7.2.1.1\(b\)](#) and [Figure 7.3.2.1](#); or
- may be at the same level as the threshold for non-cantilevered *decks* that are formed as shown in [Figure 7.2.1.1\(c\)](#).

7.2.2.2 For slatted *decks*, a minimum gap of 12 mm shall be provided between the *external wall* and the adjacent decking slat.

7.2.3 Thresholds of enclosed decks

7.2.3.1 For *enclosed decks*, the vertical separation between the opening threshold level and the upper surface of the finished *deck* surface shall be a minimum of 100 mm.

7.3 Attachment to building structure

7.3.1 Slatted non-cantilevered timber decks to walls

7.3.1.1 Junctions of slatted non-cantilevered timber *decks* with *walls* shall be made *weathertight* as shown in [Figure 7.3.1.1](#).

Figure 7.3.1.1: Junction with wall for non-cantilevered timber deck

Paragraphs [7.3.1.1](#) and [7.3.3.1](#)

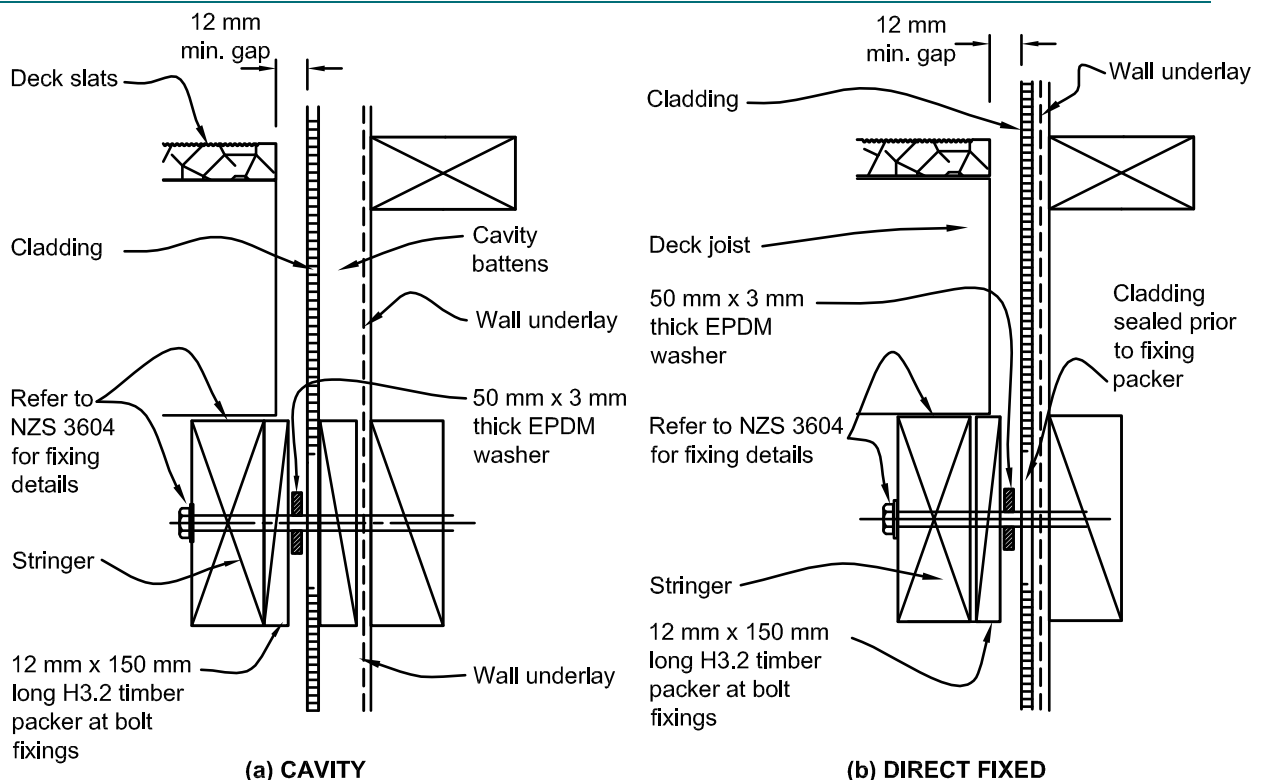

Notes:

- Not suitable for *stucco*, *EIFS*, or profiled metal *cladding*.
- The top of the *deck* slats may be level with the interior threshold.
- The same stringer-to-wall junction applies when joist hangers are used.

Decks and pergolas

7.3.1.2 Fixings for stringers shall be in accordance with NZS 3604.

COMMENT: Separating *decks* from *buildings* reduces the risk of water penetration into the *framing*.

7.3.1.3 *Wall claddings* that rely on surface coatings to reduce water absorption shall be sealed on outer faces and edges prior to fixing the stringers.

7.3.2 Slatted cantilevered timber decks to walls

7.3.2.1 *Cantilevered decks* shall have the junction with the *external wall* made *weathertight* as shown in [Figure 7.3.2.1](#). *Cladding* shall be sealed to the *saddle flashing*.

Figure 7.3.2.1: Junction with wall for cantilevered timber deck

Paragraphs [7.2.2.1](#) and [7.3.2.1](#)

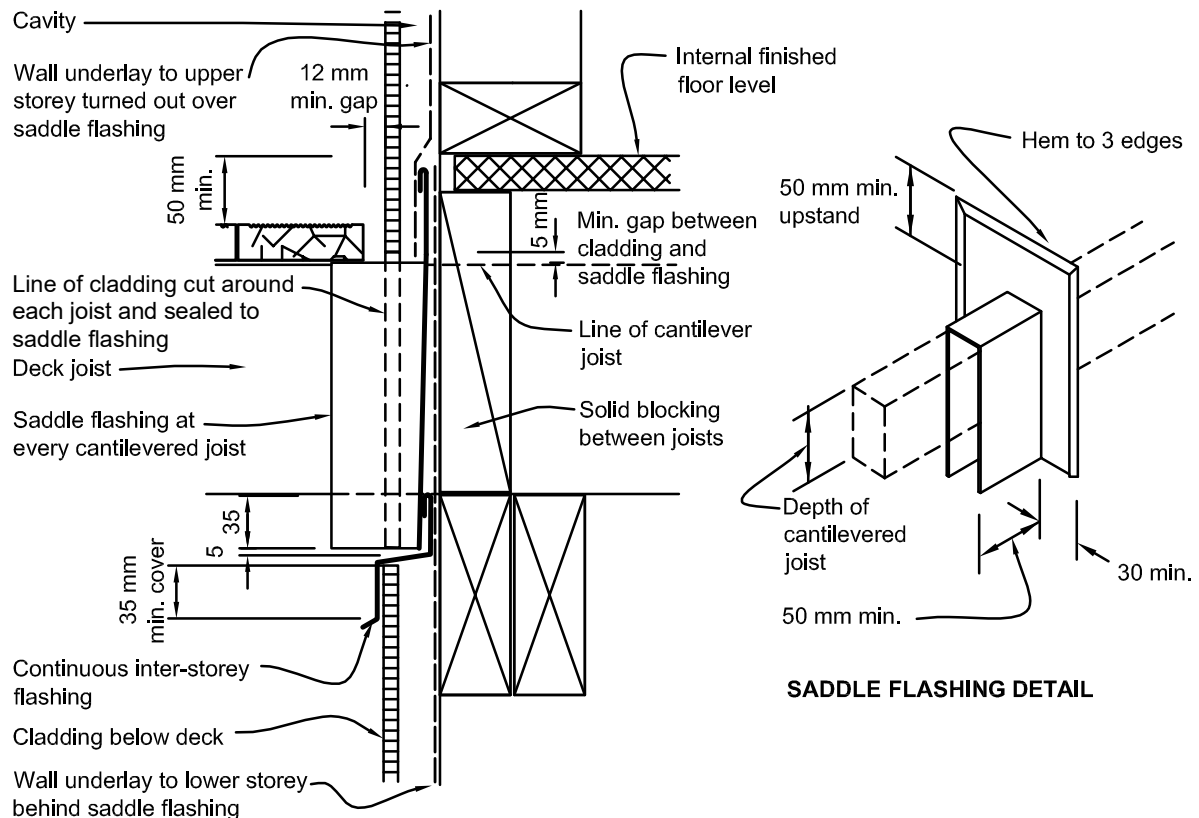

Notes:

- (1) *Wall underlay* at the back of the cavity shall be taped around joist penetrations.
- (2) The back of the *saddle flashing* shall be positioned behind the *cladding* between the upper storey and lower storey layers of *wall underlay*.
- (3) *Saddle flashing* terminates over inter-storey flashing.

7.3.3 Pergolas

7.3.3.1 Connections of other structures, such as pergolas, shall have the junction with the *external wall* made weathertight by using the deck framing connections shown in [Figure 7.3.1.1](#).

Decks and pergolas

7.4 Level thresholds

7.4.1 Level access from enclosed decks

- 7.4.1.1 Where provision for level access is required for an *enclosed deck*, this shall be provided in [Figure 7.4.1.1](#). The underlying *membrane deck* surface shall be made *weathertight* as described in Section [8.5](#).
- 7.4.1.2 Raised removable surfaces of tiles, pavers, or timber decking shall be provided over the underlying *weathertight enclosed deck* surface for cleaning and maintenance, as shown in [Figure 7.4.1.1](#). A minimum gap of 12 mm shall be provided against the *wall* or *balustrade cladding*.
- 7.4.1.3 Removable timber decking shall be over *framing* supported off the *deck membrane* as shown in [Figure 7.4.1.1](#). No fixings shall penetrate the underlying *deck membrane*.

COMMENT: Tiled boards or structural pavers sitting on proprietary supports can be adjusted according to level changes in the underlying *deck* surface. The pavers or tiled boards are spaced to allow free drainage and the ability to lift the top surface off when necessary. The timber option allows access by fixing the timber decking with stainless steel screws, so they may be removed when necessary.

7.4.2 Ground floor level access

- 7.4.2.1 Where provision for level access is required, this may be provided as shown in [Figure 7.4.2.1](#), with exterior paving or decking that complies with the *access route* requirements of Acceptable Solution D1/AS1.

COMMENT: The specific features of a *building* and its site can have a significant effect on the options available for providing level access at doors. These features include the provision of shelter, prevailing winds, and ground levels.

- 7.4.2.2 Where provision for level access is required from a concrete floor slab to exterior paving, this shall be as shown in [Figure 7.4.2.1](#) with:
- a) a channel, together with drainage provisions, across the door opening, with:
 - i) width and depth dimensions to provide capacity that meets the requirements of Building Code clause E1 Surface Water, and
 - ii) a minimum width of 200 mm and minimum depth of 150 mm, and
 - iii) a maximum length of 3700 mm, and
 - iv) 1:200 minimum fall along length of channel towards a drainage outlet, and
 - v) the channel discharging to the surface water drainage system via a sump installed in accordance with the requirements of Building Code clause E1 Surface Water; and
 - b) grating, in accordance with [Table C.1.1.1B](#) and [Table C.1.1.1C](#), over the channel, that:
 - i) is specifically detailed to suit the condition of the *building* and the site; and
 - ii) is supported independently of the door frame, and
 - iii) is removable to allow access for cleaning, and
 - iv) is specifically designed to accommodate imposed loads, and
 - v) has gaps sized to prevent the wheels of wheelchairs or mobility aids entering or being trapped, and
 - vi) has a continuous gap of 12 mm minimum from door frame and *wall cladding*; and

Decks and pergolas

c) exterior paving that:

- i) has a minimum fall of 1:40 away from the channel for a minimum distance of 1 m, and
- ii) together with the surrounding paving and ground levels, meets the drainage requirements of Building Code clause E1 Surface Water.

7.4.2.3 Where provision for level access is required from a timber floor structure to the exterior, this may be provided as shown in [Figure 7.4.2.1](#), with clearances in accordance with Subsection [9.1.2](#).

Figure 7.4.1: Level thresholds for enclosed decks

Paragraphs [7.4.1.1](#), [7.4.1.2](#), [7.4.1.3](#), [8.5.1.2](#), [9.1.9.2](#), and [Figure 7.4.2.1](#)

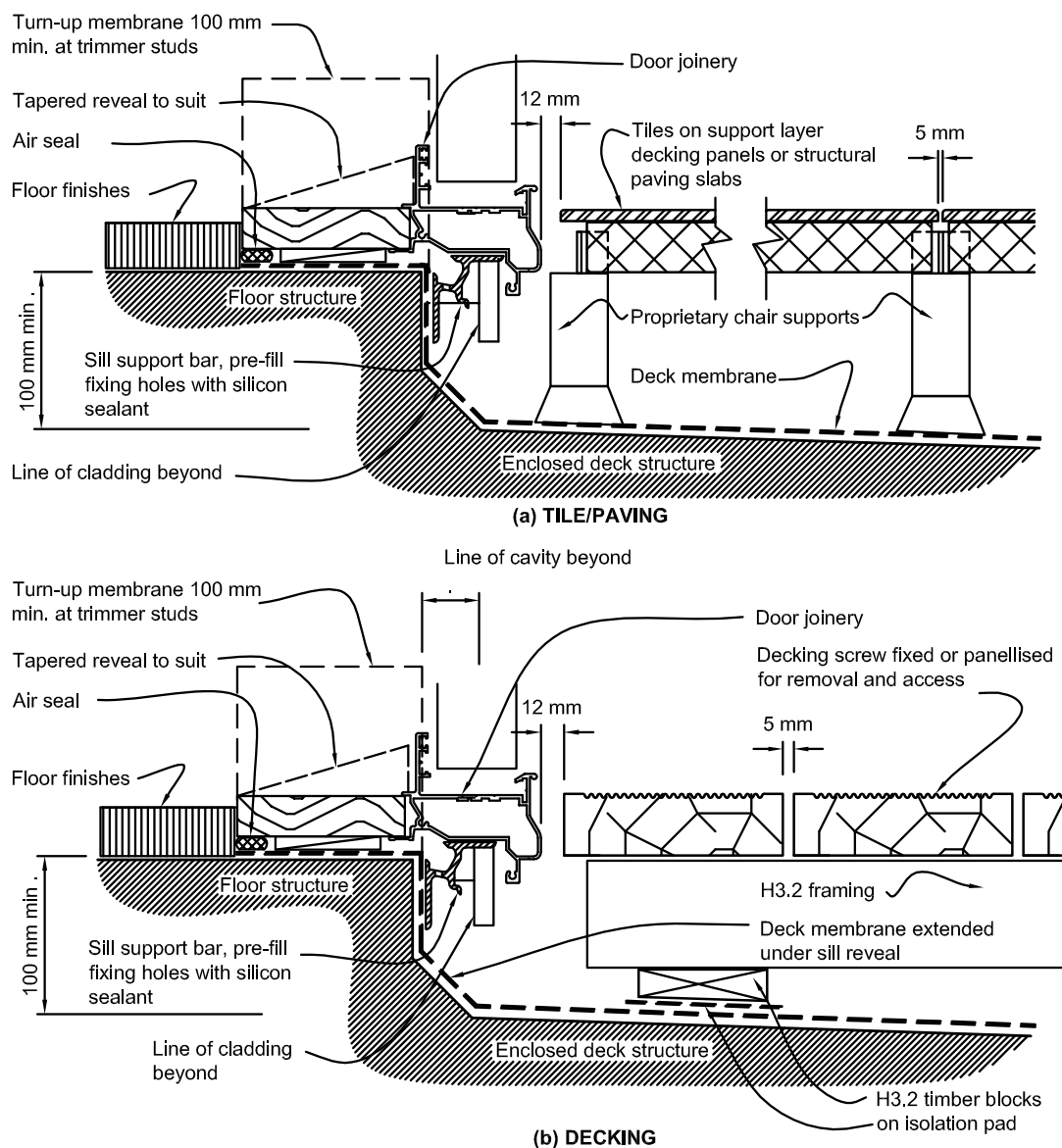

Notes:

- (1) For use for framed, above ground, *enclosed decks* with *membrane* surfaces.
- (2) Care must be taken to ensure that no fixings or sharp edges penetrate the *weathertight membrane deck* surface.
- (3) Refer also to Section [8.5](#) for *membrane decks*.

Decks and pergolas

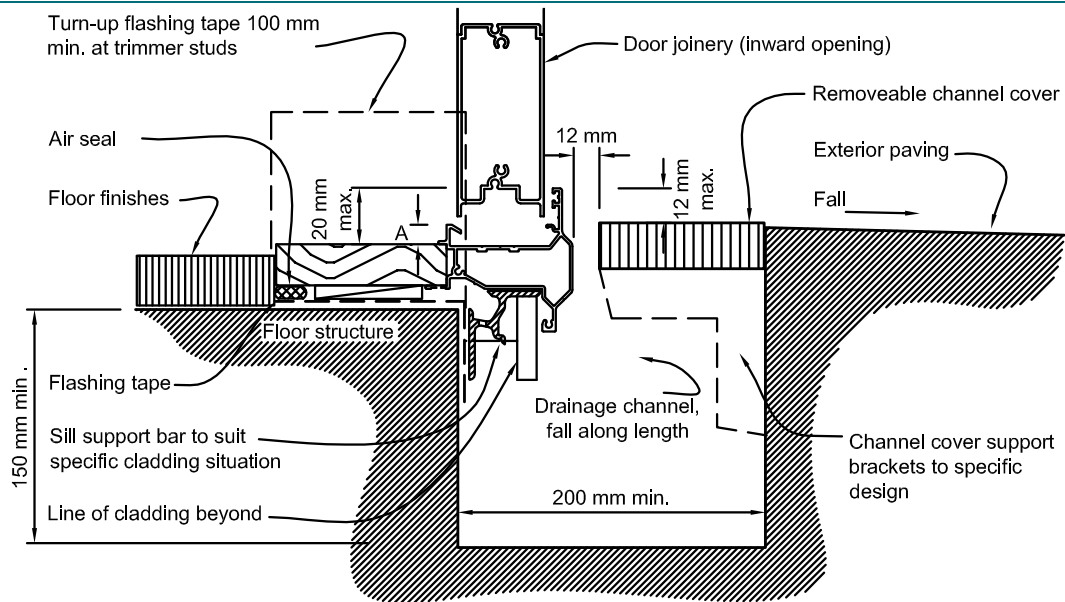
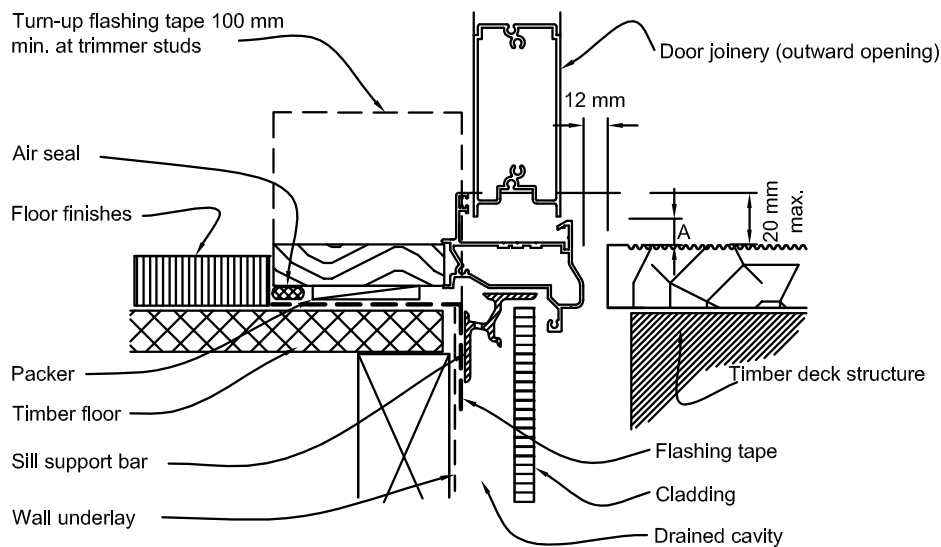
Figure 7.4.2.1: Level thresholds for ground levelParagraphs [7.4.2.1](#), [7.4.2.2](#), [7.4.2.3](#), and [9.1.9.2](#)**(a) CONCRETE SLAB****(b) TIMBER FLOOR****Notes:**

- (1) Detail (a) is suitable for use with concrete floor slabs. Refer to Paragraph [7.4.2.2](#) for requirements.
- (2) Detail (b) is suitable for use with timber floors. It may also be adapted for:
 - (a) timber decks on upper storeys as per Paragraph [7.2.2.1\(b\)](#); or
 - (b) enclosed decks with removable panels or decking as shown in [Figure 7.4.1.1](#).
- (3) Both details (a) and (b) may be adapted for inward or outward opening doors.
- (4) Exposure to wind-driven rain must be specifically taken into account when using these details. Shelter to doors and joinery must be provided where local conditions warrant.
- (5) Dimension A is the minimum dimension to maintain clearance from the bottom of the door to the finished floor or deck, to manufacturer's requirements, and to keep sill upstand height to less than 20 mm.

Decks and pergolas

7.5 Enclosed balustrades

7.5.1 Cladding systems for enclosed balustrades

7.5.1.1 *Enclosed balustrades* require a *drained cavity* for *claddings*, except for vertical corrugated profiled metal, as outlined in [Table 3.1.2.1](#), and shall be detailed as required for *parapets* described in [Part 6. Parapets, Subsection 9.1.7](#), [Figure 6.1.1.4A](#), [Figure 6.2.3.1A](#), and [Figure 6.2.3.1B](#).

7.5.1.2 Details for specific *cladding systems* are given in [Part 9. Wall claddings](#).

7.5.1.3 *Enclosed balustrade cappings* for *EIFS* and flush-finished fibre cement may include flush finishes as outlined in Subsections [9.7.8](#) and [9.9.9](#).

COMMENT: Reports on leaky *buildings* show these junctions have been prone to leakage and care must be taken to detail and build them correctly.

7.5.2 Deck drainage

7.5.2.1 For *decks* with *enclosed balustrades*, provision for drainage shall be in accordance with Subsections [8.5.4](#) and [8.5.8](#).

7.5.3 Balustrade-to-wall junctions

7.5.3.1 *Enclosed balustrade-to-wall* junctions shall be flashed to direct water clear of the outside face of the *cladding system* using a *saddle flashing* as shown in [Figure 6.2.3.1A](#) and [Figure 6.2.3.1B](#).

COMMENT: Reports on leaky *buildings* show that these junctions are prone to leakage and care must be taken in detailing and in building them correctly.

7.5.4 Balustrade-to-deck floor junctions

7.5.4.1 The junction of the *enclosed balustrade* with the floor of the *enclosed deck* shall be made *weathertight* as shown in [Figure 7.5.4.1](#).

Figure 7.5.4.1: Enclosed balustrade – bottom of cladding

Paragraphs [7.5.4.1](#) and [9.1.2.2](#) and [Table 4.5.1.1](#)

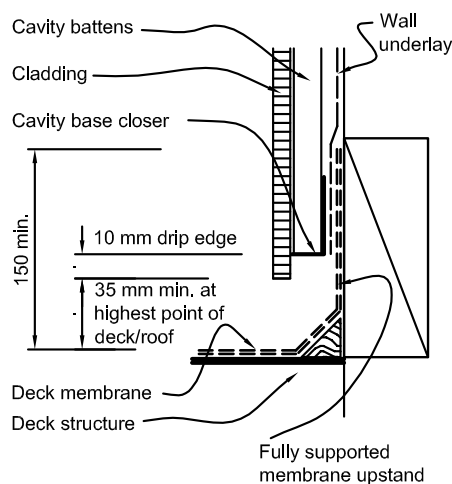

Decks and pergolas

7.5.5 Metal cappings

- 7.5.5.1 Metal *cappings* to enclosed *balustrades* shall have dimensions as outlined in [Table 4.5.1.1](#).
- 7.5.5.2 Metal *cappings* shall have the same requirements as outlined for *parapets* in Subsection [6.2.2](#), with the exception of the:
- slope to the top of the capping, for *buildings* other than housing to be as in Acceptable Solution F4/AS1; and
 - drip edges* are required to both sides of the *capping*. The *drip edge* to the *deck* side of the *capping* shall be a *bird's beak* as shown in [Figure 4.4.3.2](#).

COMMENT: A *bird's beak* drip edge will avoid danger of injury resulting from the sharp edge of a kick-out.

7.5.6 Stanchions

- 7.5.6.1 *Stanchions* for *handrails*, signs, television aerials, or similar structures shall be side-fixed through the *cladding* system into *framing*, as shown in [Figure 7.5.6.1](#). These fixings are not included for *stucco*, *EIFS*, or profiled metal in this acceptable solution.
- 7.5.6.2 Fixing shall be to vertical surfaces only. The sealant shall be compatible with the washer.

Figure 7.5.6.1: Stanchion fixing

Paragraph [7.5.6.1](#)

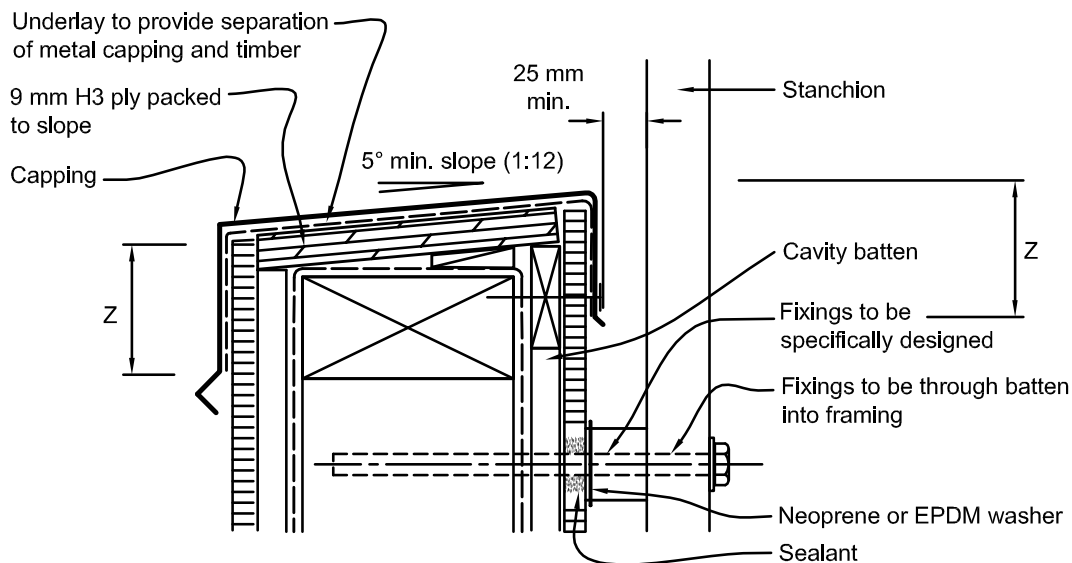

Note: (1) Dimension Z varies by *wind zone*. Refer to [Table 4.5.1.1](#).

Roof claddings

Part 8. Roof claddings

8.1 Demonstrating compliance

8.1.1 Overview

8.1.1.1 This part contains provisions for *roof cladding systems*.

8.1.1.2 *Roof cladding systems* in this part include:

- a) *masonry tiles* in Section [8.2](#); and
- b) pressed metal tiles in Section [8.3](#); and
- c) profiled metal *roof claddings* in Section [8.4](#); and
- d) *membrane roofing* in Section [8.5](#).

COMMENT: For *roofs* used to collect water for human consumption, refer to AS/NZS 4020.

8.1.1.3 Other *roof claddings* are beyond the scope of this acceptable solution.

8.1.1.4 Soffits and verges of all projecting eaves shall be closed in. Refer to Subsection [5.1.4](#) for details.

8.1.2 Fixings

8.1.2.1 Fixings shall be as specified in Sections [8.2](#), [8.3](#), [8.4](#), and [8.5](#).

8.1.2.2 Materials for fixing *roof claddings* and *flashings*, where necessary, shall be selected from [Table C.1.1.1A](#), [Table C.1.1.1B](#), and [Table C.1.1.1C](#) to minimise corrosion.

COMMENT: The use of stainless steel fixings is not recommended by steel manufacturers for use with coated steel in severe marine and industrial environments, as they are considered to cause deterioration.

8.1.3 Roof underlays

8.1.3.1 *Roof underlays* shall be to [Table C.2.1.1](#) and NZS 2295, and be either:

- a) R1 heavy weight kraft; or
- b) R2 self-supporting kraft.

8.1.3.2 *Underlays* shall be:

- a) laid with minimum numbers of laps; and
- b) lapped at all side and end laps by minimum 150 mm; and
- c) run horizontally for *roof pitches* below 10°; and
- d) run horizontally or vertically for *roof pitches* above 10°; and
- e) have *anti-ponding boards* at lower edges of *masonry tiles* (refer to [Figure 8.2.5.1C\(b\)](#) and Subsection [8.2.4](#)).

8.1.3.3 Prevent sagging of *roof underlay* by either:

- a) for R1 *underlays*, fully support with a corrosion resistant material; and
- b) for R2 self-supporting *underlays*, laid to maximum 1.2 metre span between adjacent supports.

COMMENT: Solvent in freshly LOSP-treated timber can affect bitumen in *underlays*. Any solvent should be allowed to evaporate before the *roof underlay* is installed.

Roof claddings

8.1.4 Gutters, downpipes, and spreaders

- 8.1.4.1 Gutters, downpipes and spreaders, including *eaves gutters/spoutings* are required for the drainage of *roof water*, and shall:
- be to the minimum dimensions shown in this acceptable solution, or calculated to provide capacity that meets the requirements of Building Code clause E1 Surface Water, whichever is the greater; and
 - if reduced in depth to allow entry of a *valley gutter*, have its capacity calculated using the reduced depth; and
 - for internal gutters, *valley gutters*, and *hidden gutters*:
 - have no fixings in gutter bottoms or sides, and
 - be continuously supported on H1.2 minimum treated timber gutter boards or H3 ply which is separated from metal by *roof underlay strip*.
- 8.1.4.2 *Eaves gutters/spoutings* shall:
- be to any of the materials outlined for *flashings* in Section 4.2 except Subsections 4.2.10, 4.2.11, and 4.2.12; and
 - have a minimum cross-sectional area of 2500 mm²; and
 - be designed to overflow water to the outside.
- 8.1.4.3 Upper *roofs* shall drain:
- via downpipes directly to ground level where possible; or
 - where discharging to a lower *roof*, be fitted with a spreader as detailed in Figure 8.1.4.5.
- 8.1.4.4 External downpipes shall:
- be formed from any of the materials outlined for *flashings* in Section 4.2 except Subsections 4.2.10, 4.2.11, and 4.2.12; and
 - have a maximum catchment area of 25 m² if discharging on to a lower *roof area*.
- 8.1.4.5 Spreaders shall:
- be formed from any of the materials outlined for *flashings* in Section 4.2 except Subsections 4.2.10, 4.2.11, and 4.2.12; and
 - be to Figure 8.1.4.5; and
 - not be used on masonry tile *roofs* unless a *roof underlay* is installed; and
 - discharge directed away from roofing laps and clear of *roof penetrations*.

COMMENT: Design calculations for a specific *roof* may allow larger catchment areas per spreader to be used.

The alternative to a spreader is to direct an upper level downpipe into a rainwater head.

The ends of spreaders should be blocked off where a sideways flow of water is against laps in *roof claddings*.

Roof claddings

Figure 8.1.4.5: Spreader for roof discharge

Paragraphs [8.1.4.3](#) and [8.1.4.5](#)

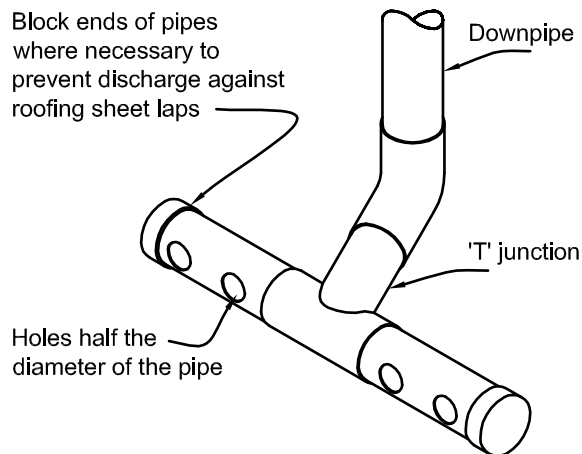

Notes:

- (1) Hole positions to avoid joints in roofing.
- (2) When downpipe is located in corner, spreader to be L-shaped.

8.1.5 Internal gutters

8.1.5.1 Internal gutters shall:

- a) be formed with continuous butyl or EPDM strip complying with Subsection [4.2.10](#), with no cross-joints in the gutter, or aluminium, copper, stainless steel, or zinc sheet to Section [4.2](#), with joints that are welded; and
- b) where butyl or EPDM, be minimum 1.5 mm *membrane* thickness, or 1.0 mm thickness for gutters less than 1 metre wide; and
- c) have a minimum slope of 1:100; and
- d) have capacity that meets the requirements of Building Code clause E1 Surface Water and have a freeboard depth of at least 30 mm, but in no case have any dimension less than those shown in [Figure 8.4.11.4](#).

COMMENT: The minimum dimensions shown in [Figure 8.4.11.4](#) provide sufficient working space to ensure the gutter is able to be accessed, *constructed*, and maintained without undue risk of failure, for *buildings* within the scope and construction methodologies of this acceptable solution.

In some *buildings*, *specific design* may be able to show that smaller dimensions do not prevent adequate access, construction and maintenance of the gutter; however such gutters are outside the scope of this acceptable solution.

The requirements of Building Code clause E1 Surface Water ensure the gutter has sufficient flow capacity to handle the runoff from the particular roof catchment area. Flow capacity will govern the sizing of internal gutters when the roof area and/or rainfall intensity require a gutter of more than the minimum dimensions.

Acceptable Solutions E1/AS1 and E1/AS2 provide means of calculating the capacity of internal gutters. If E1/AS1 is used, a freeboard depth of 30 mm must be added. If E1/AS2 is used, the calculation method already includes a freeboard depth of 30 mm.

Roof claddings

- 8.1.5.2 For roofs other than *membrane roofs*, internal gutters shall:
- discharge into a rainwater head as shown in [Figure 8.5.4.1B\(a\)](#) and [Figure 8.5.4.1B\(b\)](#); or
 - discharge to an internal outlet to [Figure 8.5.8.1\(b\)](#) or [Figure 8.5.8.1\(c\)](#) with overflows provided by either:
 - a second outlet to a rainwater head, or
 - an overflow as shown in [Figure 8.5.4.1B\(c\)](#), and positioned below the level of any potential overflow into the *building*.
- 8.1.5.3 For internal gutters and *membrane roofing*, refer to Section [8.5](#).

8.1.6 Valley gutters and hidden gutters

- 8.1.6.1 *Valley gutters* and *hidden gutters* shall be *constructed* as shown in [Figure 8.4.11.2](#) and [Figure 8.4.11.3](#) for the applicable *roof cladding* (except for *membrane roofing*) and:
- not change direction in plan; and
 - have a minimum underlap to *roof cladding* as specified in [Figure 8.2.5.1E](#), [Figure 8.3.6.1D](#), [Figure 8.4.11.2](#), and [Figure 8.4.11.3](#) for the relevant *roof cladding*; and
 - be formed from any of the materials outlined for *flashings* in Section [4.2](#) except Subsection [4.2.11](#), and [4.2.12](#); and
 - be fixed at upper ends only, and be secured with a purpose-made clip system for the remaining length to enable expansion/ contraction along the length of the gutter; and
 - discharge into an internal gutter or *eaves gutter/spouting*; and
 - have minimum slopes:
 - of 8° for *hidden gutters*, and
 - to [Table 8.1.6.1](#) for *valley gutters*.

Table 8.1.6.1: Maximum catchment areas for valley gutters

Paragraphs [8.1.6.1](#), [8.4.11.3](#), [Figure 8.2.5.1E](#), [Figure 8.3.6.1D](#), and [Figure 8.4.11.3](#)

Gutter width (mm)	Maximum catchment area (m ²) ⁽¹⁾	Minimum roof pitch
250	25	8°
160 to 249	16	12.5°

Note: (1) Catchment areas are limited to gutters in accordance with Subsection [8.1.6](#) and rainfall intensity with average recurrence interval (ARI) no greater than 200 mm per hour.

COMMENT: Gutters for lower-pitched *roofs*, or for catchment areas other than those shown in [Table 8.1.6.1](#), require *specific design*. Additional information may be found in the New Zealand Metal Roof and Wall Cladding Code of Practice.

- 8.1.6.2 Where spreaders discharge onto lower *roofs*:
- hidden gutters* shall receive no discharge from downpipes or spreaders; and
 - downpipes and spreaders shall not discharge directly into a *valley gutter*; and
 - valley gutters* be minimum 250 mm wide where receiving run off from spreaders.

8.1.7 Roof penetrations

- 8.1.7.1 *Roof penetrations* shall be made *weathertight* in accordance with Sections [8.2](#), [8.3](#), [8.4](#), and [8.5](#).
- 8.1.7.2 Where *roof penetrations* are required for large openings such as *roof lights* and *chimneys*, this acceptable solution is limited to the following requirements:

Roof claddings

- a) the edge of roofing penetrations over 200 mm wide shall be supported in either direction with additional *framing* as shown in [Figure 8.1.7.2A](#); and
- b) for the catchment area of the roof above the penetration as shown in [Figure 8.1.7.2B](#), the roof length shall be limited to:
 - i) for profiled metal roofing, [Table 8.4.12.1](#); and
 - ii) for other *roof claddings*, the areas shown in [Table 8.1.7.2](#).

COMMENT: *Flashings* for roof penetrations not included in this acceptable solution require *specific design*. For pipe penetrations, refer to details for the *roof cladding* material used.

Figure 8.1.7.2A: Penetration support

Paragraphs [8.1.7.2](#) and [8.4.12.2](#)

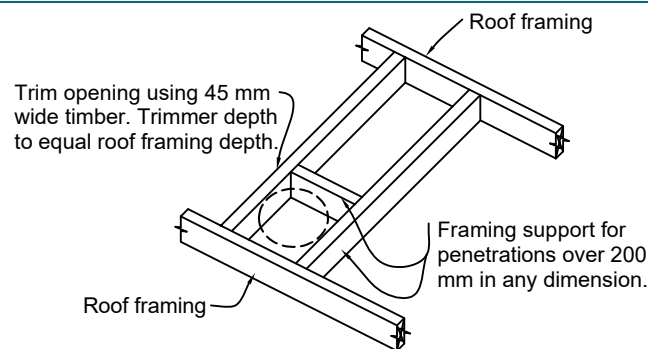
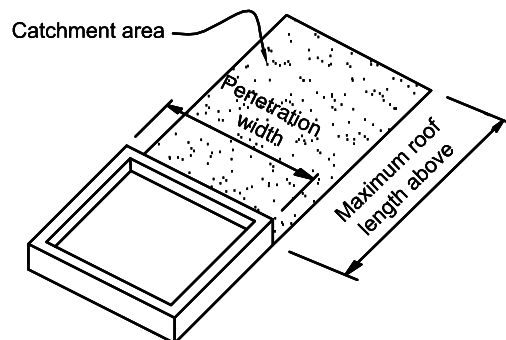

Figure 8.1.7.2B: Catchment area for penetrations

Paragraph [8.1.7.2](#)



Note: (1) For profiled metal roofing, refer to [Table 8.4.12.1](#) for maximum roof lengths above penetrations. For other roofing *cladding*, refer to [Table 8.1.7.2](#) for maximum roof lengths above penetrations.

Table 8.1.7.2: Maximum catchment areas above penetrations

Paragraph [8.1.7.2](#) and [Figure 8.1.7.2B](#)

Penetration width (mm)	Maximum roof length above penetrations (m) ⁽¹⁾
800 to 1200	4
600 to 799	6
400 to 599	8
0 to 399	10

Note: (1) For profile metal roofing, refer to [Table 8.4.12.1](#).

Roof claddings

8.2 Masonry tiles

8.2.1 Use and limitations

8.2.1.1 This section contains provisions for masonry tile *roofs*.

8.2.2 Materials

8.2.2.1 Masonry *roof* tiles shall be either:

- concrete tiles that meet the requirements of NZS 4206 or AS 2049; or
- clay tiles that meet the requirements of AS 2049.

8.2.2.2 Tiles shall be categorised according to the following three profile types

- Type I: double profile tiles having two distinct watercourses with a minimum watercourse depth of 18 mm; or
- Type II: single profile tiles having one water-course depth of a minimum of 25 mm; or
- Type III: tiles not fitting the Type I or Type II categories, and includes flat tiles and those resembling slates, shakes and shingles.

8.2.2.3 Materials for *flashings*, gutters, and fixings shall be in accordance with [Part 4. Flashings](#), and:

- be selected from [Table C.1.1.1A](#) to minimise corrosion; and
- be compatible with mortar and bedding in accordance with [Table C.1.1.1B](#) and [Table C.1.1.1C](#).

8.2.3 Installation

8.2.3.1 *Masonry tile roof cladding* shall be installed in accordance with NZS 4206 or AS 2050 onto minimum H1.2 treated timber battens, except the minimum pitch shall be as specified in [Table 8.2.3.1](#). Where required in AS 2050 and [Table 8.2.3.1](#), *underlay* shall comply with [Table C.2.1.1](#).

Table 8.2.3.1: Minimum pitches for masonry tiles

Paragraph [8.2.3.1](#) and [8.2.3.2](#)

Tile material	Profile Type	Minimum pitch with underlay ^{(1),(2),(3)}	Minimum pitch without underlay ^{(1),(2),(3)}
Concrete tiles (to <i>rafter</i> length 4.5 m)	Type I	15°	20°
	Type II	20°	–
	Type III	25°	–
Clay tiles (to <i>rafter</i> length 4.5 m)		20°	25°
		20°	–
		25°	–

Notes:

(1) Increase pitch by 1° per additional 0.5 metres of *rafter* length over 4.5 m.

(2) Minimum pitch may be reduced where Paragraph [8.2.3.4](#) applies.

(3) *Roof underlay* is required for any *roof* receiving discharge from a spreader or for *roofs* in *wind zone* Very High or Extra High.

COMMENT: *Rafter* length, tile profile, and *wind zone* all affect the allowable minimum pitch of a tile *roof*.

Rafters longer than in [Table 8.2.3.1](#) may require the addition of *underlay*.

Manufacturers may have specific profiles that are suitable for pitches lower than those shown in [Table 8.2.3.1](#), but these are outside the scope of this acceptable solution.

Roof claddings

- 8.2.3.2 Fixing and fixing patterns shall be to NZS 4206, with the exception that nails shall penetrate a minimum of 35 mm into timber battens, and the minimum pitches and *roof underlay* shall be as described in [Table 8.2.3.1](#) and [Table C.2.1.1](#).
- 8.2.3.3 Use 304 or 316 stainless steel fixings for exposure zones B, C, D and E, or hot dip galvanised fixings at 450 g/m² for Zone B and Zone C. Refer to [Table C.1.1.1A](#) for exposure zones.
- 8.2.3.4 Where *masonry tiles* have been shown to comply with the dynamic weathertightness test requirements of AS 4046.9, a lower pitch may be used provided it is not less than 15°.

8.2.4 Anti-ponding boards

- 8.2.4.1 *Masonry tile roofs with underlays* shall have *anti-ponding boards* installed to [Figure 8.2.5.1C](#).
- 8.2.4.2 Where *anti-ponding boards* are used, these shall be set to a minimum fall of 5° (1:12), and shall be treated minimum H1.2 for solid timber and H3 for plywood.

8.2.5 Details and flashings

- 8.2.5.1 *Roof edges, junctions, and penetrations* shall be formed and flashed using the details in:
- [Figure 8.2.5.1A](#) for ridges; and
 - [Figure 8.2.5.1B](#) for barges; and
 - [Figure 8.2.5.1C](#) for eaves; and
 - [Figure 8.2.5.1D](#) for apron *flashings*; and
 - [Figure 8.2.5.1E](#) for valleys; and
 - [Figure 8.2.5.1F](#) for *roof/wall* ridges; and
 - [Figure 8.2.5.1G](#) for pipe penetrations; and
 - [Figure 8.2.5.1H](#) for abutments at framed penetrations; and
 - [Figure 8.2.5.1I](#) for flashing to framed penetrations.
- 8.2.5.2 Holes in tiles for pipe penetrations shall be machine-cut to minimise the size of the hole.

Figure 8.2.5.1A: Masonry tile ridge

Paragraph [8.2.5.1](#)

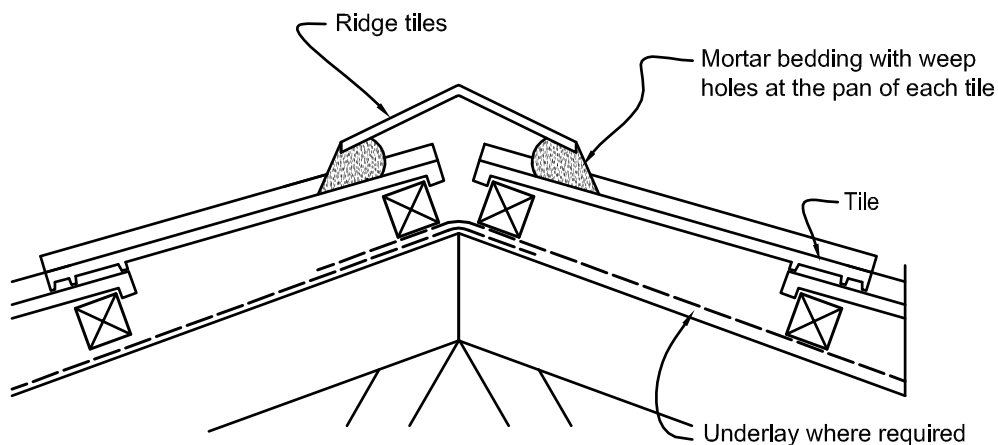

Roof claddings

Figure 8.2.5.1B: Barge for masonry tile

Paragraph [8.2.5.1](#)

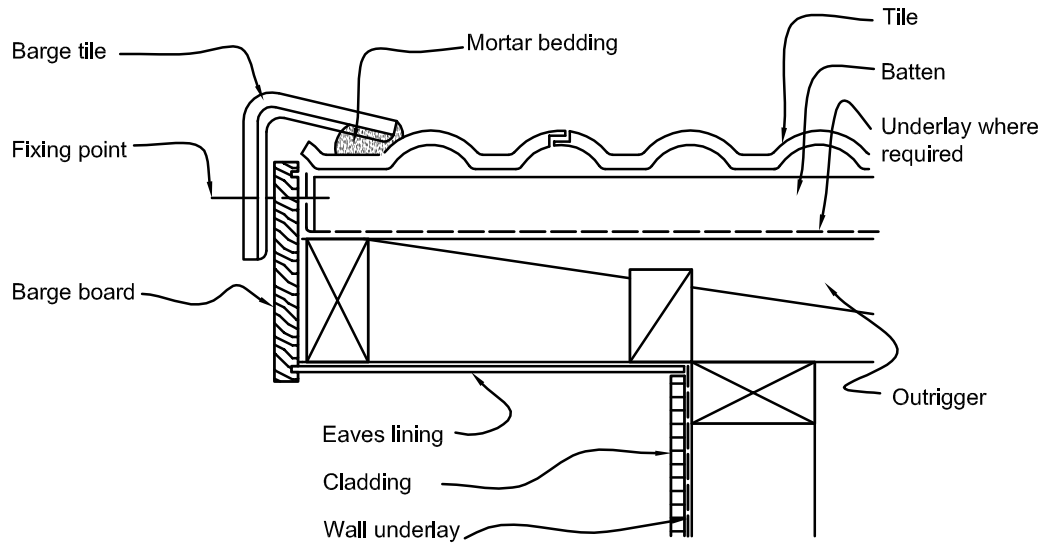
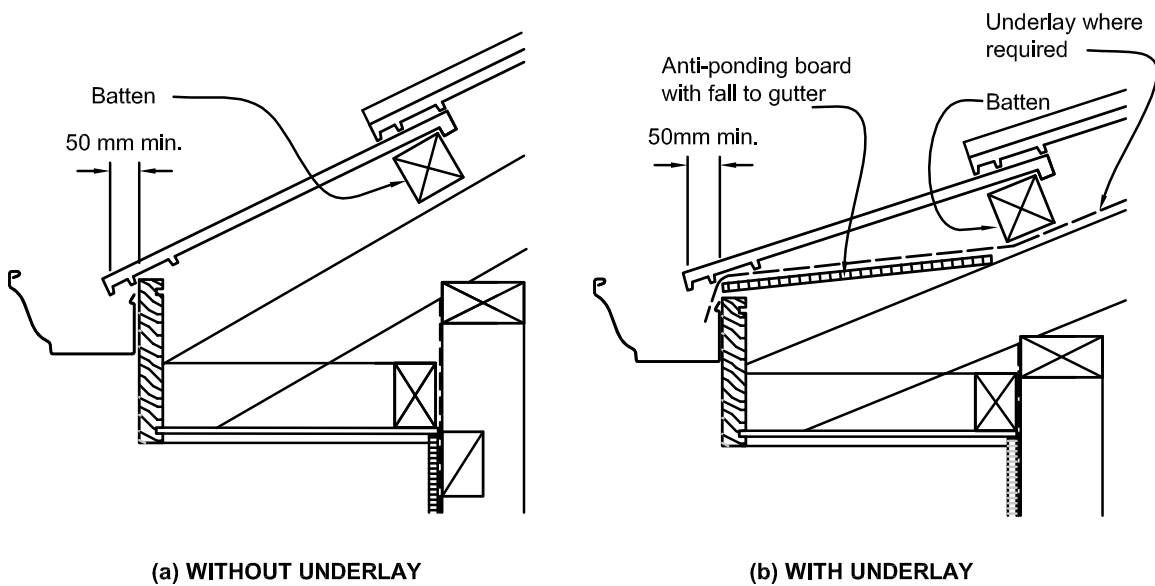

Figure 8.2.5.1C: Timber fascia eaves for masonry tile

Paragraphs [8.1.3.2](#), [8.2.4.1](#), and [8.2.5.1](#)



Notes:

- (1) *Anti-ponding boards* are required for tile roofs with *underlays*.
- (2) For tiles types and roof pitches requiring roof *underlays*, refer to [Table 8.2.3.1](#).

Roof claddings

Figure 8.2.5.1D: Apron details for masonry tile

Paragraph [8.2.5.1](#) and [Table 4.5.1.1](#)

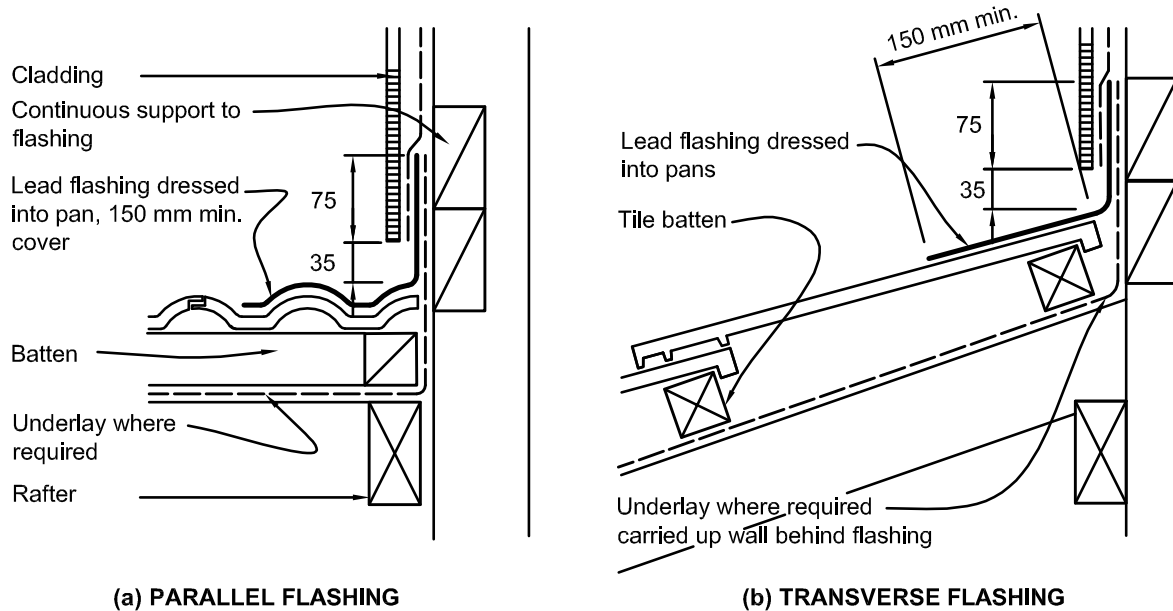
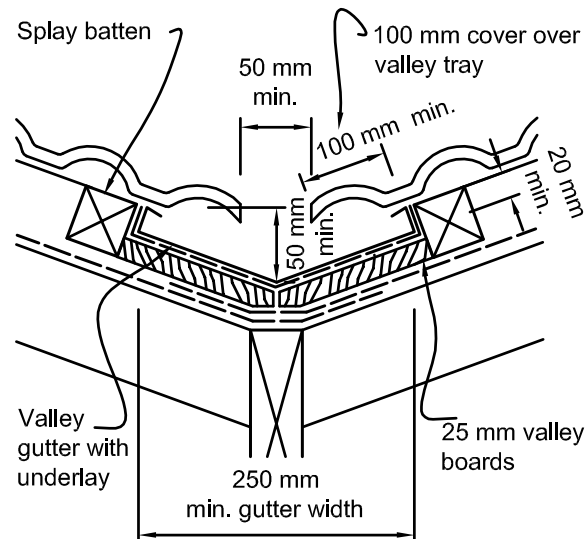

Figure 8.2.5.1E: Valley for masonry tile

Paragraphs [8.1.6.1](#) and [8.2.5.1](#)



Notes:

- (1) For maximum *roof* catchment areas for *valley gutters*, refer to [Table 8.1.6.1](#).
- (2) The minimum width of the *valley gutter* may be reduced to 160 mm, provided the *roof* catchment area is in accordance with [Table 8.1.6.1](#). In this case, the cover of tiles over the gutter shall be reduced to 60 mm to provide a clearance between tiles of 40 mm.

Roof claddings

Figure 8.2.5.1F: Roof/wall ridge for masonry tile

Paragraph [8.2.5.1](#)

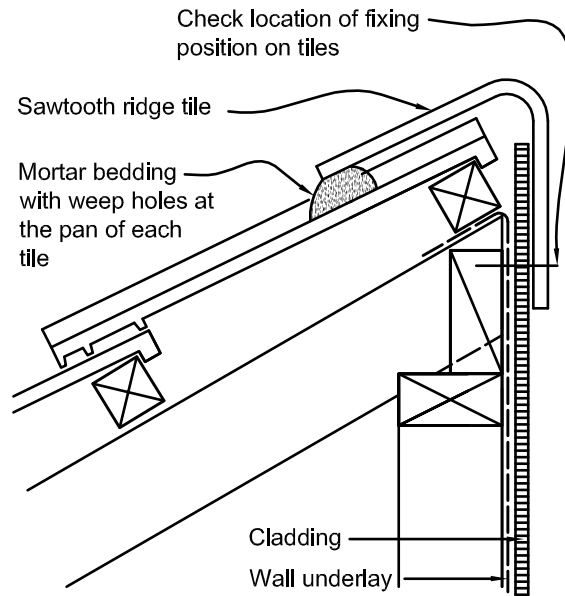
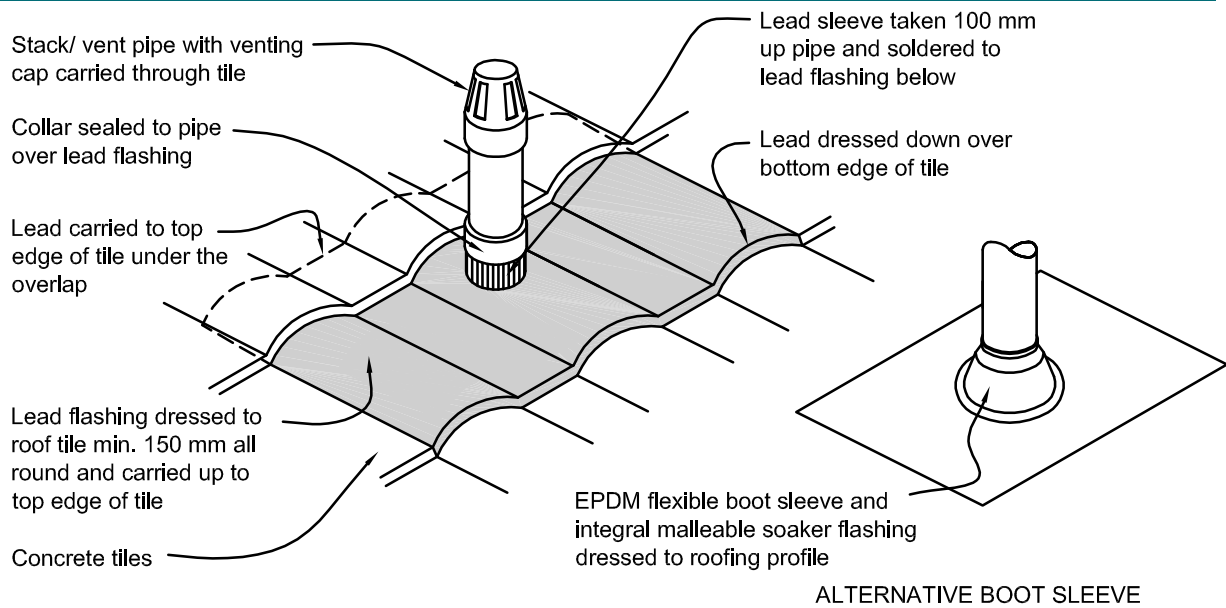

Figure 8.2.5.1G: Pipe penetration for masonry tile

Paragraphs [8.2.5.1](#) and [8.3.6.3](#)



Roof claddings

Figure 8.2.5.1H: Abutment at framed penetration for masonry tile

Paragraph [8.2.5.1](#), [Figure 8.2.5.1I](#), and [Table 4.5.1.1](#)

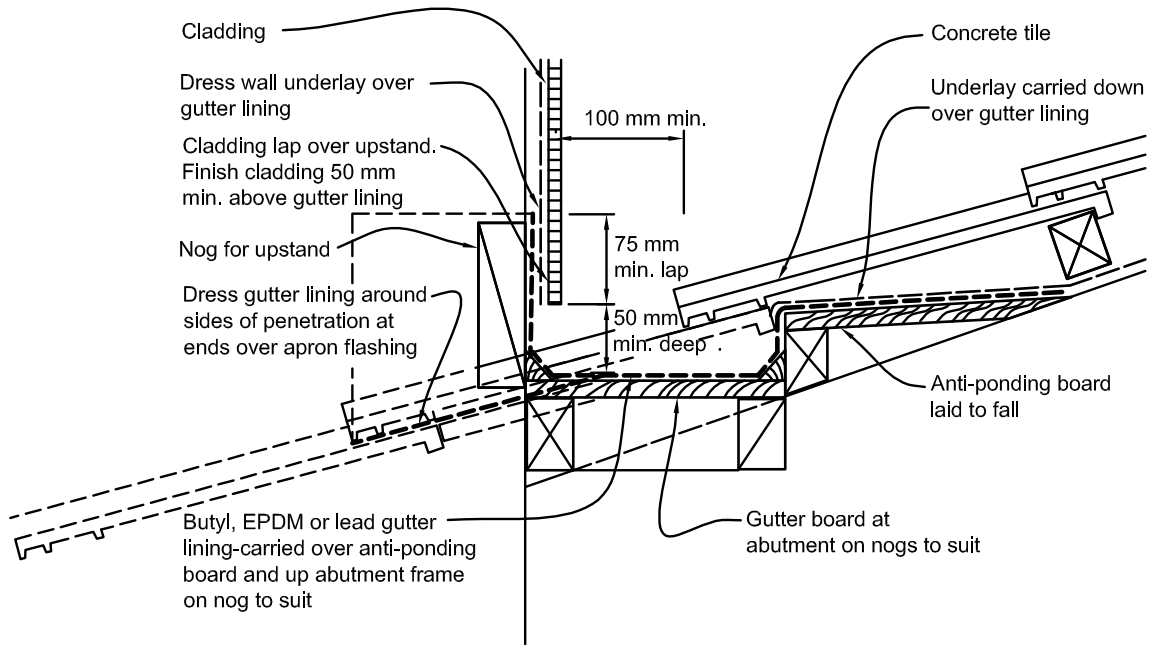
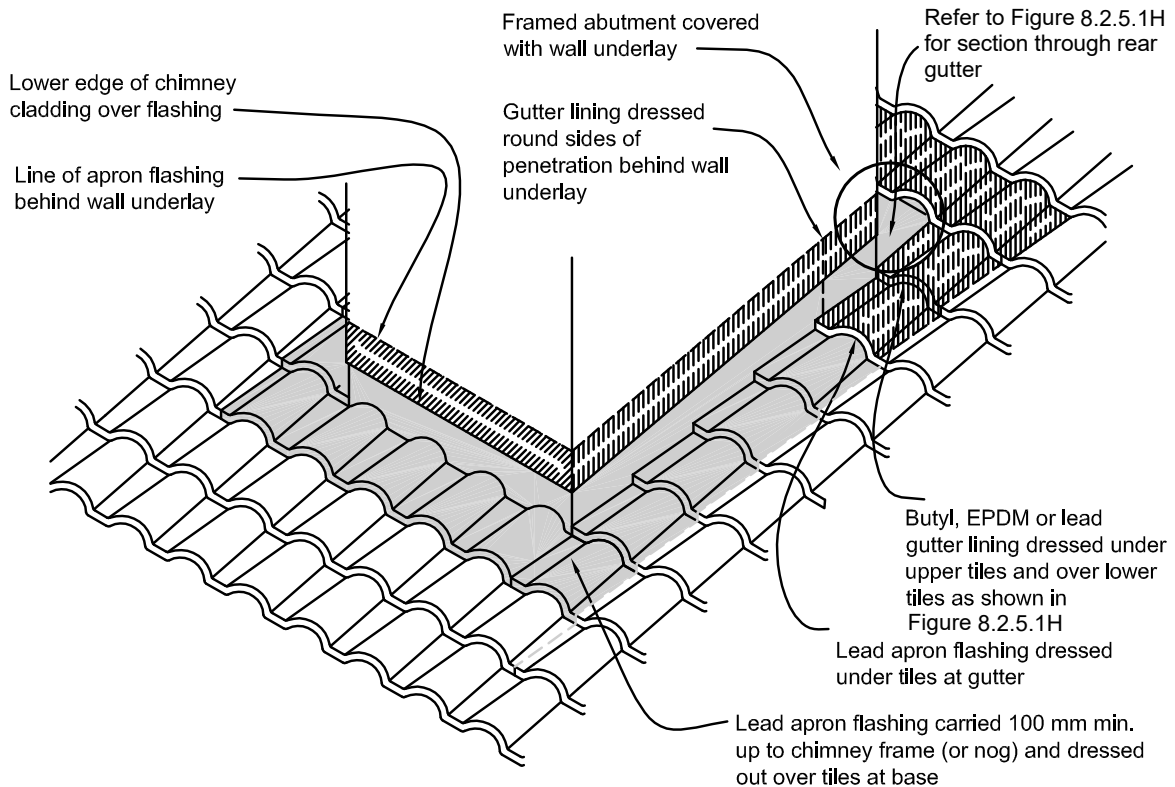

Figure 8.2.5.1I: Flashing to framed penetration for masonry tile

Paragraph [8.2.5.1](#)



Roof claddings

8.3 Pressed metal tiles

8.3.1 Use and limitations

8.3.1.1 This section contains provisions for pressed metal tile roofs.

COMMENT: Additional guidance on pressed metal tiles can be found in the New Zealand Metal Roof and Wall Cladding Code of Practice.

8.3.2 Materials

8.3.2.1 Tiles and their accessories shall meet the requirements of NZS 4217.

8.3.2.2 Steel for the manufacture of pressed metal tile and *flashing* systems shall:

- have a *base metal thickness (BMT)* of 0.39 mm minimum; and
- be grade G300 or G250; and
- be selected for corrosion protection according to the intended exposure zone as shown in [Table C.1.1.1A](#).

8.3.2.3 Coatings for steel may include factory-applied finishes complying with AS/NZS 2728, or factory-painted or bonded resin and chip finishes of minimum 15-year durability.

8.3.2.4 Aluminium for the manufacture of pressed metal tiles and *flashing* systems shall comply with AS/NZS 1734, and shall:

- have a *base metal thickness (BMT)* of 0.7 mm minimum; and
- be minimum 5000 series; and
- for pre-painted aluminium, have a factory applied finish complying with AS/NZS 2728.

COMMENT: The exposure zone in which a *building* is located can affect the durability of metal roofing and *flashings*. Exposure zones are defined in NZS 3604, based on the likely exposure to wind-driven sea-salt. In geothermal or corrosive industrial atmospheres, as defined in NZS 3604, corrosion may occur and *specific design* is required.

Exposure zones are based on AS/NZS 2728. AS/NZS 2728 lists atmospheric classes derived from ISO 9223 for Australia and New Zealand.

8.3.2.5 Metal *flashings* are generally supplied by the metal tile manufacturer, and shall comply with Paragraphs [8.3.2.2](#), [8.3.2.3](#), and [8.3.2.4](#) and [Table 4.5.1.1](#).

COMMENT: Metal tile manufacturers supply pre-folded or formed accessories and recommendations for their installation.

8.3.3 Roof pitch

8.3.3.1 General approximations of profile types for standard profile and shake or shingle profile metal roof tiles are shown in [Figure 8.3.3.1](#).

Figure 8.3.3.1: Metal tile profiles

Paragraph [8.3.3.1](#)

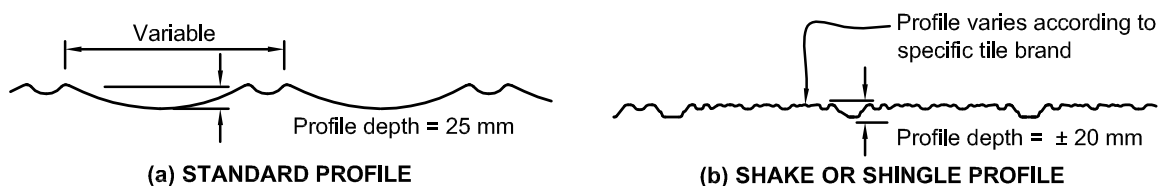

Roof claddings

8.3.3.2 The minimum *roof* pitches for metal tiles where rafter length does not exceed 12 m shall be:

- a) 12° (1:4.75) for profiles resembling standard profiles; and
- b) 15° (1:3.75) for profiles resembling shingle or shake profiles.

8.3.3.3 Where *rafter* length exceeds 12 m, increase minimum pitch by 1° per additional 0.5 m.

COMMENT: Panels are available in a wide range of profiles.

Where manufacturers have more stringent requirements, these should be followed to optimise performance and to avoid invalidating guarantees.

8.3.4 Underlay

8.3.4.1 All metal tile roofing shall have a *roof underlay* installed. *Roof underlay* shall be to [Table C.2.1.1](#). Refer to Subsection [8.1.3](#) for installation details.

8.3.4.2 If LOSP-treated timber is used, *roof underlay* shall not be applied until the LOSP solvent has been allowed to evaporate.

COMMENT: Solvent in freshly LOSP-treated timber can affect bitumen in *underlays*. Any solvent should be allowed to evaporate before the *roof underlay* is installed.

8.3.5 Fixings

8.3.5.1 Pressed metal tiles shall be fixed as shown in [Figure 8.3.5.1](#), with:

- a) 50 x 2.8 mm hot-dipped galvanized painted flat-head annular-grooved nails. For fixings through the top of the tiles, use neoprene washers containing no more than 15% by weight carbon black content; and
- b) four fixings per sheet through:
 - i) the turn-down of the tiles for the body of the *roof*, and
 - ii) the top of the profile slope for sheets at the *eaves*, avoiding the weather channel of the tiles.

Figure 8.3.5.1: Metal tile fixings

Paragraph

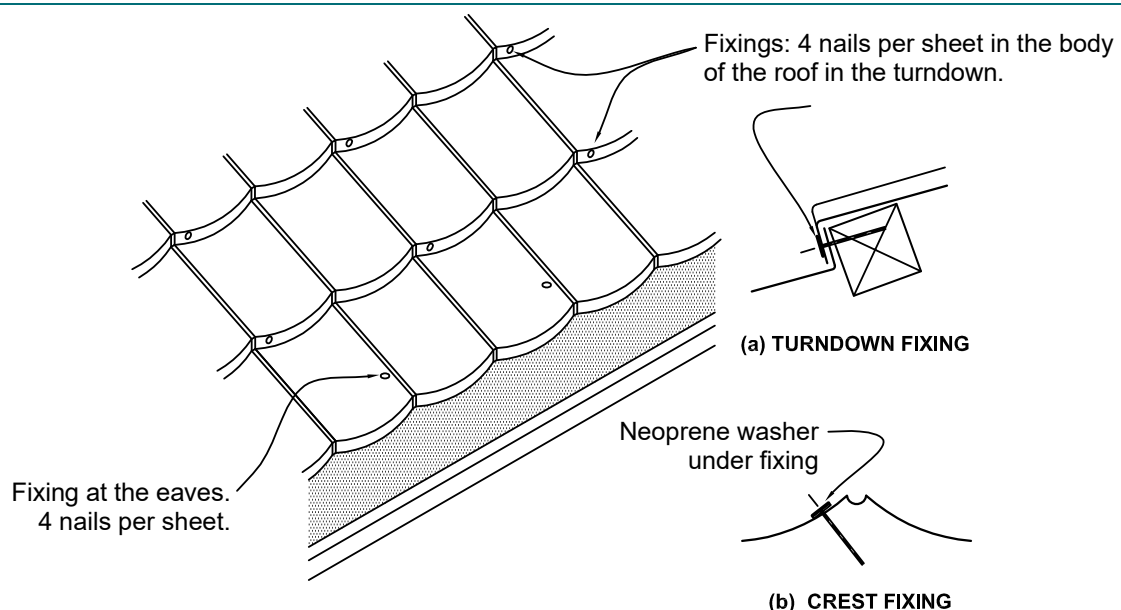

Roof claddings

8.3.6 Details and flashings

8.3.6.1 Roof edges and junctions shall be formed and flashed using the details shown in:

- Figure 8.3.6.1A for ridge or hip flashings for metal tile; and
- Figure 8.3.6.1B for apron flashings for metal tile; and
- Figure 8.3.6.1C for eaves and barges for metal tile; and
- Figure 8.3.6.1D for hidden gutters and valley gutters for metal tile.

8.3.6.2 Refer to Subsection 5.1.3 for termination of roofs against wall claddings.

8.3.6.3 Pipe penetrations shall be flashed using EPDM flashings similar to that shown for masonry tiles in Figure 8.2.5.1G.

COMMENT: Use purpose-made preformed rooflights and ventilators supplied by the manufacturer of the tiles where available.

Figure 8.3.6.1A: Ridge or hip flashings for metal tile

Paragraph 8.3.6.1

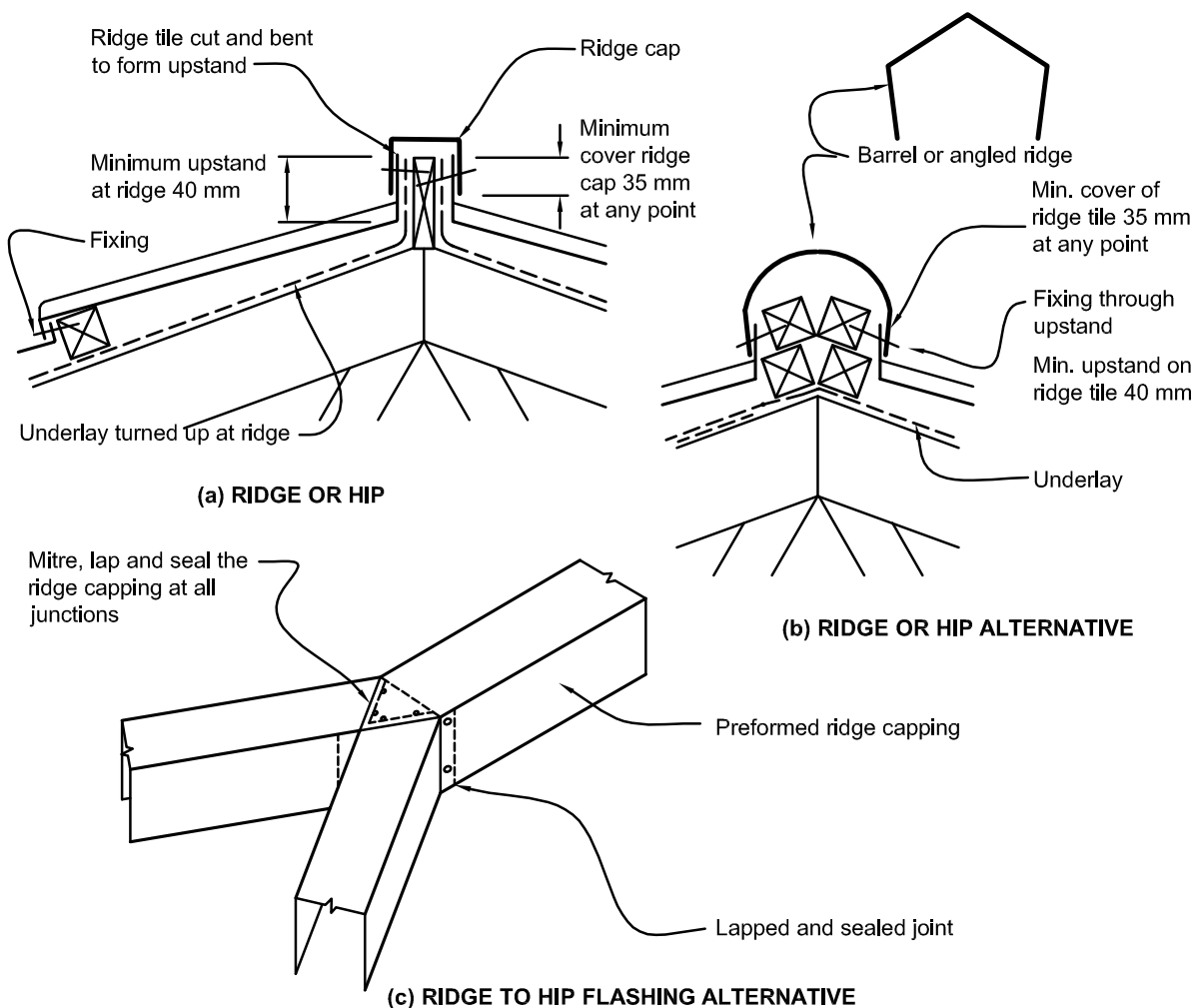

Note: (1) For alternative ridge profiles, ridge to hip capping must be preformed to suit profile.

Roof claddings

Figure 8.3.6.1B: Apron flashings for metal tile

Paragraphs [5.1.2.2](#), [8.3.6.1](#), and [Table 4.5.1.1](#)

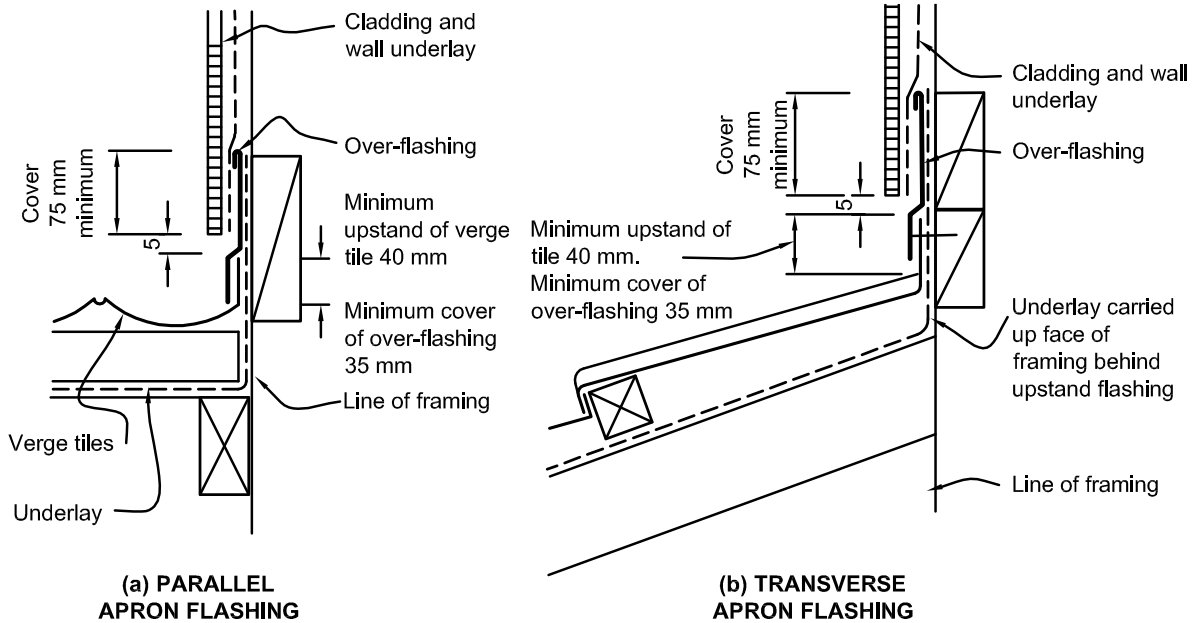
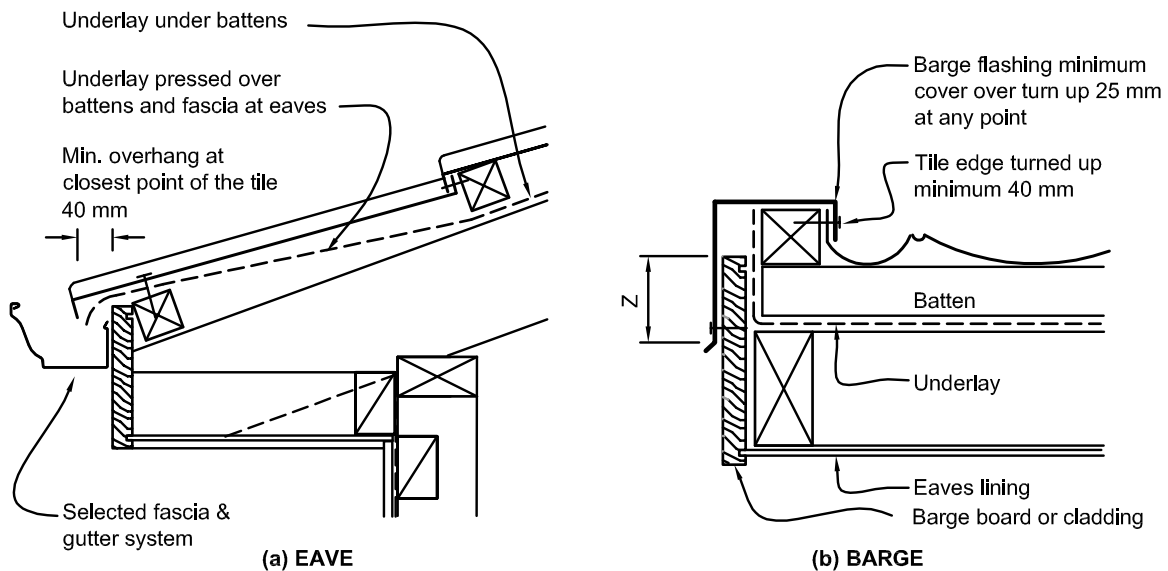

Figure 8.3.6.1C: Eaves and barges for metal tile

Paragraph [8.3.6.1](#)



Notes:

- (1) If alternative barge *flashing* profiles are used, these profiles must achieve equivalent covers.
- (2) For dimension Z, refer to [Table 4.5.1.1](#).

Roof claddings

Figure 8.3.6.1D: Hidden gutter and valley gutter flashings to metal tile

Paragraphs [8.1.6.1](#), [8.3.6.1](#), and [Table 4.5.1.1](#)

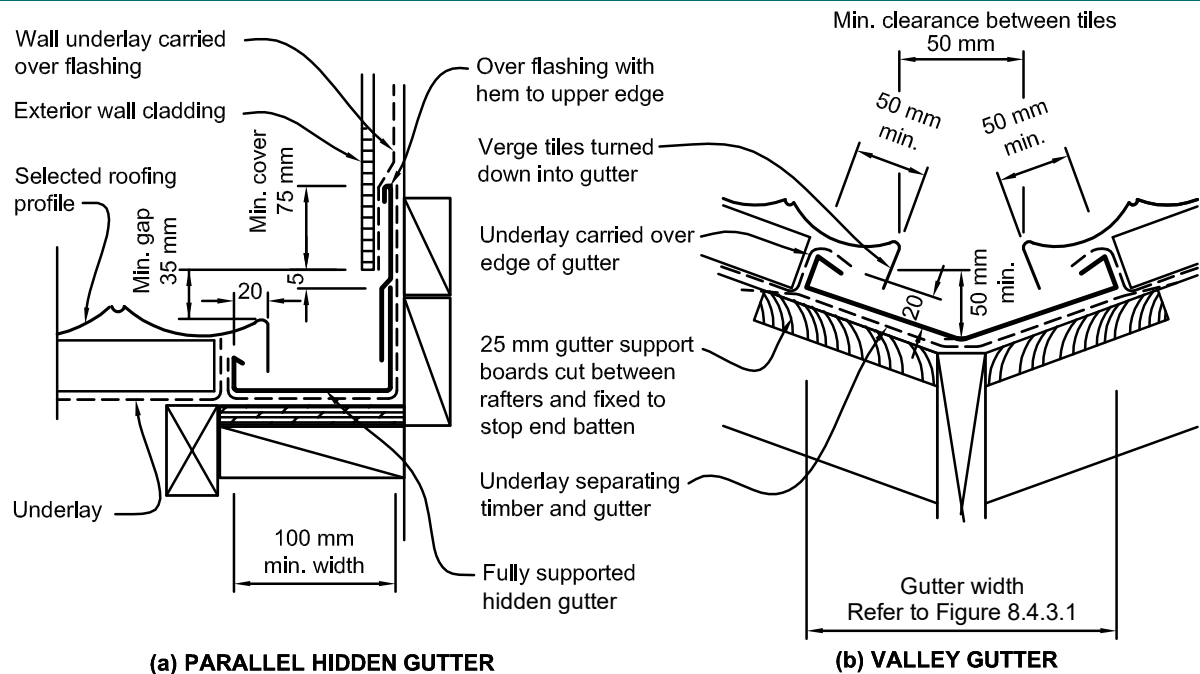

Notes:

- (1) For the maximum catchment areas for *valley gutters*, refer to [Table 8.1.6.1](#).
- (2) The minimum width of the *valley gutter* may reduce to 160 mm provided that the *roof catchment area* is in accordance with [Table 8.1.6.1](#). In this case, the minimum dimensions shall apply as shown.
- (3) For (a), where the gutter finishes within the length of the *wall*, step the lower part of the gutter out to 10 mm past the *cladding* line, while maintaining the required clearances, to allow the gutter to feed into the lower *eaves* gutter.

8.4 Profiled metal roof cladding

8.4.1 Use and limitations

- 8.4.1.1 This section contains provisions for profiled metal *roof claddings*.
- 8.4.1.2 Profiled metal *roof cladding* shall:
 - a) be profiled as outlined in Subsection [8.4.3](#); and
 - b) not be curved; and
 - c) not have sheets of lengths greater than 18 metres.

COMMENT: If curved profiled metal sheet is used, the radius of the curve may affect durability. *Specific design* is required, and manufacturers and the New Zealand Metal Roof and Wall Cladding Code of Practice should be consulted for recommendations.

- 8.4.1.3 The layout of profiled metal *roofs* shall not result in *valley gutters* that change direction in plan.

Roof claddings

8.4.2 Materials

- 8.4.2.1 Metal *roof cladding* and *flashings* shall be selected according to the intended exposure zone as per [Table C.1.1.1A](#).

COMMENT: The exposure zone in which a *building* is located can affect the durability of metal roofing and *flashings*. Exposure zones are defined in NZS 3604, based on the likely exposure to wind-driven sea-salt. In geothermal or corrosive industrial atmospheres, as defined in NZS 3604, corrosion may occur and *specific design* is required.

Exposure zones are based on AS/NZS 2728. AS/NZS 2728 lists atmospheric classes derived from ISO 9223 for Australia and New Zealand.

- 8.4.2.2 Materials for the manufacture of profiled steel *roof cladding* shall:

- have a BMT of 0.4 mm minimum; and
- be grade G550, or G300 for rolled, crimped, or trough profile roofing; and
- be coated, or coated and factory painted, to provide the corrosion protection required by Paragraph [8.4.2.1](#).

- 8.4.2.3 Aluminium for the manufacture of profiled aluminium roofing shall comply with AS/NZS 1734, and be a minimum:

- base metal thickness* (BMT) of 0.7 mm; and
- 5000 series.

- 8.4.2.4 Pre-painted aluminium roofing shall have a factory-applied finish complying with AS/NZS 2728.

COMMENT: A deterioration in the appearance of the coating of the metal does not necessarily relate to a deterioration in the *weathertightness* of the *roof cladding*.

8.4.3 Profiles

- 8.4.3.1 Profiles covered in this acceptable solution are shown in [Figure 8.4.3.1](#) and consist of:

- corrugated – curved with a crest height of 16.5 mm minimum; and
- trapezoidal* – symmetrical or asymmetrical with a minimum crest height of 19 mm, and for asymmetrical a flat or lightly profiled pan width of 210 mm maximum between crests; and
- trough profile* – with vertical ribs at a minimum height of 38 mm, and flat or lightly profiled pans of 210 mm maximum between crests.

Figure 8.4.3.1: Profiled metal profiles

Paragraphs [8.4.3.1](#), [9.6.1.1](#), [9.6.3.1](#), and [Table 3.1.3.2](#)

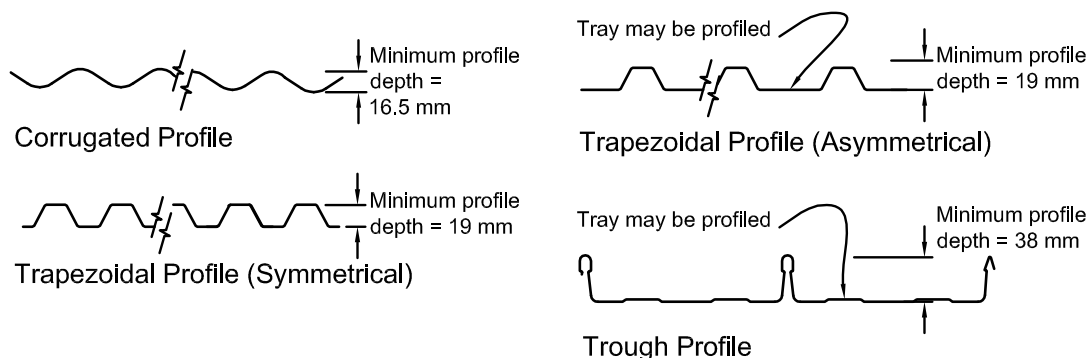

Note: (1) [Table 8.4.4.2A](#), [Table 8.4.4.2B](#), and [Table 8.4.4.2C](#) have limited profile requirements for the given roofing spans.

Roof claddings

8.4.4 Roof pitch and span

8.4.4.1 For *roofs* up to 18 metres in length without end laps, pitches shall be:

- a) corrugated – not less than 8° (1:7); and
- b) *trough profile* – not less than 3° (1:20); and
- c) *trapezoidal* – not less than:
 - i) 4° (1:14) where the crest height is less than 27 mm, or
 - ii) 3° (1:20) where the crest height is 27 mm or higher.

COMMENT: For *roofs* over 18 metres in length refer to the manufacturer for minimum pitch requirements. Where manufacturers have more stringent requirements, these should be followed to optimise performance and to avoid invalidating guarantees.

8.4.4.2 The maximum span and fixing patterns of profiled metal *roof cladding* between purlins shall be as given in:

- a) [Table 8.4.4.2A](#) for steel corrugated profiled roofing with 0.4 mm BMT and 16.5 mm minimum profile height; and
- b) [Table 8.4.4.2B](#) for steel corrugated roofing with 0.55 mm BMT and 16.5 mm minimum profile height; and
- c) [Table 8.4.4.2C](#) for steel *trough profiled* roofing with 0.55 mm BMT, 46 mm minimum profile height, and 210 mm maximum pan width; and
- d) [Table 8.4.4.2D](#) for steel *trapezoidal* profiled roofing with 0.4 mm BMT, 27 mm minimum profile height, and minimum 5-rib profiles; and
- e) [Table 8.4.4.2E](#) for steel *trapezoidal* profiled roofing with 0.55 mm BMT, 27 mm minimum profile height, and minimum 5-rib profiles.

COMMENT: For *purlin* sizes, spacing and fixing, refer to NZS 3604.
Additional support will be required around roof-mounted services such as air-conditioning in order to avoid *roof* distortion.
Spans and fixing patterns not covered by the tables in this subsection may be possible but require *specific design*. Consult roofing manufacturers for information.

Table 8.4.4.2A: Steel corrugated profiled roofing – 0.4 mm BMT and 16.5 mm minimum profile height

Paragraphs [8.4.4.2](#), [8.4.6.1](#), and [Figure 8.4.3.1](#)

Purlin spacing End span (m)	Purlin spacing Intermediate span (m)	Low and Medium wind zones ⁽¹⁾	High and Very High wind zones ⁽¹⁾	Extra High wind zones ⁽¹⁾
0.4	0.6	C2	C2	C2
0.6	0.9	C2	C2	C1
0.8	1.2	C2	C1	C1

Note: (1) C1 fixing pattern is hit 1, miss 1, ... C2 fixing pattern is hit 1, miss 1, hit 1, miss 2 ...

Roof claddings

Table 8.4.4.2B: Steel corrugated profiled roofing – 0.55 mm BMT and 16.5 mm minimum profile height
Paragraphs [8.4.4.2](#), [8.4.6.1](#), and [Figure 8.4.3.1](#)

Purlin spacing End span (m)	Purlin spacing Intermediate span (m)	Low and Medium wind zones ⁽¹⁾	High and Very High wind zones ⁽¹⁾	Extra High wind zones ⁽¹⁾
0.4	0.6	C3	C3	C3
0.6	0.9	C3	C3	C3
0.8	1.2	C3	C3	C3
1.15	1.6	C3	C3	C2

Note: (1) C2 fixing pattern is hit 1, miss 1, hit 1, miss 2 ... C3 fixing pattern is hit 1, miss 2, hit 1, miss 3 ...

Table 8.4.4.2C: Steel trough profiled roofing – 0.55 mm BMT, 46 mm minimum profile height, and maximum pan width 210 mm

Paragraphs [8.4.4.2](#), [8.4.6.1](#), and [Figure 8.4.3.1](#)

Maximum span of roof cladding End span (m) ^{(1),(2),(3)}	Maximum span of roof cladding Intermediate span (m) ^{(1),(2),(3)}
1.1	1.6

Notes:

- (1) For all building wind zones.
- (2) Trough profile with 0.4 mm BMT steel is excluded from this acceptable solution.
- (3) For profile heights and pan widths outside this range, refer to supplier's literature for fixing patterns and spans.

Table 8.4.4.2D: Steel trapezoidal profiled roofing – 0.40 mm BMT, 27 mm minimum profile height, and minimum 5-rib profiles

Paragraphs [8.4.4.2](#) and [8.4.6.1](#)

Purlin spacing End span (m) ⁽¹⁾	Purlin spacing Intermediate span (m) ⁽¹⁾	Low and Medium wind zones ⁽²⁾	High and Very High wind zones ⁽²⁾	Extra High wind zones ⁽²⁾
0.4	0.6	T2	T2	T1
0.6	0.9	T2	T1	T1
0.8	1.2	T2	T1	T1
1.2	1.8	SED	SED	SED

Notes:

- (1) For profile heights and pan widths outside this range, refer to supplier's literature for fixing patterns and spans.
- (2) T1 fixing pattern is fix every crest... T2 fixing pattern is hit 1, miss 1... SED requires specific engineering design.

Table 8.4.4.2E: Steel trapezoidal profiled roofing – 0.55 mm BMT, minimum profile height 27 mm, and minimum 5-rib profiles

Paragraphs [8.4.4.2](#) and [8.4.6.1](#)

Purlin spacing End span (m) ⁽¹⁾	Purlin spacing Intermediate span (m) ⁽¹⁾	Low and Medium wind zones ⁽²⁾	High and Very High wind zones ⁽²⁾	Extra High wind zones ⁽²⁾
0.4	0.6	T2	T2	T2
0.6	0.9	T2	T2	T2
0.8	1.2	T2	T2	T2
1.2	1.8	T2	T1	T1

Notes:

- (1) For profile heights and pan widths outside this range, refer to supplier's literature for fixing patterns and spans.
- (2) T1 fixing pattern is fix every crest... T2 fixing pattern is hit 1, miss 1...

Roof claddings

8.4.5 Underlay

8.4.5.1 All profiled metal long-run roofing shall have a *roof underlay* installed to [Table C.2.1.1](#). Refer to Subsection [8.1.3](#) for installation details.

8.4.6 Fixings: corrugated and trapezoidal

8.4.6.1 Fixings shall be as shown in [Table 8.4.4.2A](#), [Table 8.4.4.2B](#), [Table 8.4.4.2D](#), and [Table 8.4.4.2E](#) and shall be a minimum 12-gauge screw, as shown in [Figure 8.4.6.1](#), that complies with Class 4 of AS 3566.2.

COMMENT: Screw fixing is recommended for metal roofing as there is less likelihood of the fixing 'backing out' than with a nail.

The spacing requirements for fixings are conservative, and a *specific design* may produce a more optimum spacing, especially with the use of load-spreading washers. Consult roofing manufacturers for information.

8.4.6.2 Fixings shall:

- be fixed through crests; and
- penetrate *purlins* by a minimum of 40 mm for nail fixings and 30 mm for screw fixings; and
- include sealing washers of neoprene (having a carbon black content of 15% or less by weight); and
- have profiled washer and EPDM washer where required for expansion by Paragraph [8.4.8.2](#).

Figure 8.4.6.1: Corrugated and trapezoidal fixings and sheet lap

Paragraphs [8.4.6.1](#), [8.4.8.2](#), and [9.6.4.1](#)

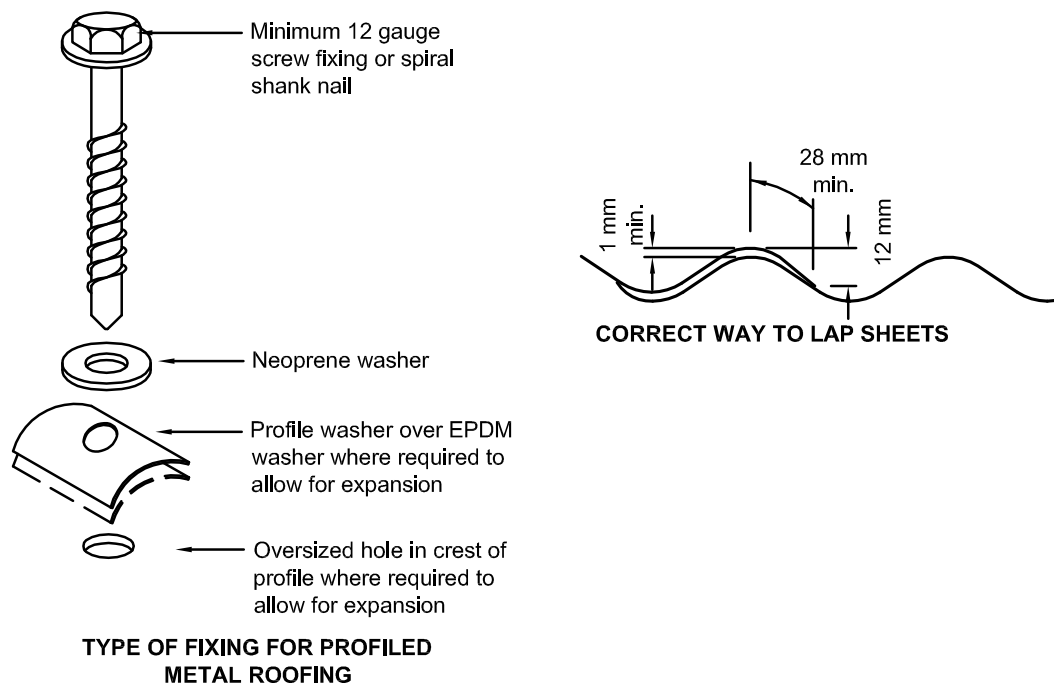

Roof claddings

8.4.7 Fixings: trough profile

- 8.4.7.1 Clip fixings for *trough profiles* and spans as shown in [Table 8.4.4.2C](#) shall be as shown in [Figure 8.4.7.1](#), and shall:
- have a minimum *BMT* of 0.9 mm; and
 - be a minimum width of 30 mm; and
 - be made from a material compatible with the *cladding*, refer to [Table C.1.1.1A](#) and [Table C.1.1.1B](#); and
 - have clips fastened with a minimum of two 10-gauge by 30 mm wafer head hot-dipped galvanised screws which comply with Class 3 of AS 3566.2.

Figure 8.4.7.1: Typical trough profile fixings

Paragraph [8.4.7.1](#)

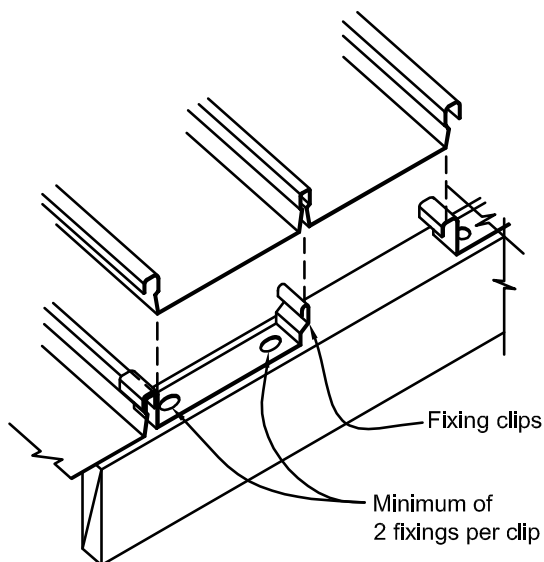

Note: (1) *Roof underlay* not shown for clarity.

8.4.8 Allowance for expansion

- 8.4.8.1 Allowance shall be made for expansion of corrugated and *trapezoidal roof cladding* as shown in [Table 8.4.8.1](#).
- 8.4.8.2 Where [Table 8.4.8.1](#) requires profiled washers, allowance shall be made for expansion by:
- fixing the top 50% (closest to the ridge) with conventional fixings; and
 - fixing the lower 50% with sealing washers fixed over profiled washers as shown in [Figure 8.4.6.1](#), and:
 - using oversized holes, and
 - positioning fixing in centre of hole.

Table 8.4.8.1: Expansion provisions

Paragraphs [8.4.8.1](#) and [8.4.8.2](#)

Material	< 8 m	8 to 12 m	12 to 18 m	> 18 m
Steel ⁽¹⁾	NSR	Profiled washers	Profiled washers	SD
Aluminium ⁽¹⁾	Oversized holes	Profiled washers	SD	SD

Note: (1) SD requires *specific design*. NSR has no special requirements.

Roof claddings

8.4.9 Flashings

8.4.9.1 Materials for *flashings* shall be compatible with the *roof cladding* material as per [Table C.1.1.1B](#) and [Table C.1.1.1C](#), and shall be in accordance with Section 4.2.

8.4.9.2 Turn-downs to cover flashings shall comprise, as appropriate to the roofing type:

- soft edge* to cover *flashings* complying with Section 4.5 (refer to [Figure 8.4.9.2A](#) for example of use and [Table C.1.1.1B](#) and [Table C.1.1.1C](#)); or
- notched turn-downs to cover *flashings* shall comply with Section 4.5 (refer to [Figure 8.4.9.2B](#) for example of use).

Figure 8.4.9.2A: Soft edge flashing

Paragraph [8.4.9.2](#)

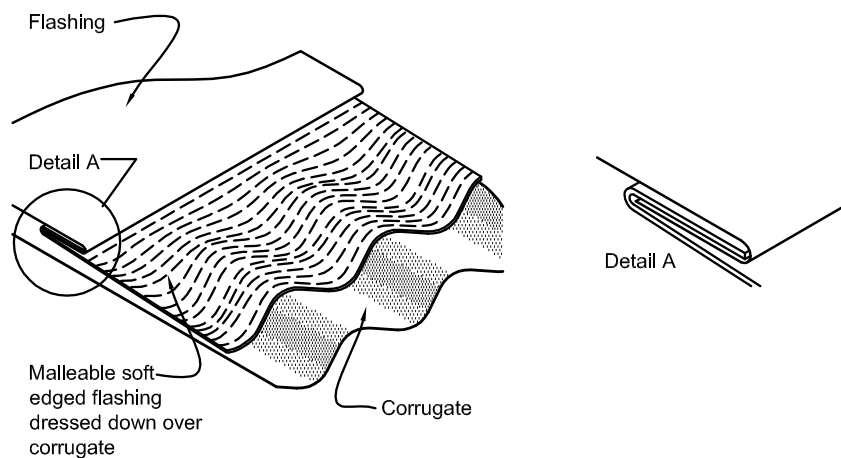

Note: (1) *Apron flashing* cover varies according to the *wind zone* (refer to refer to [Table 4.5.1.1](#)).

Figure 8.4.9.2B: Trapezoidal notched flashing

Paragraph [8.4.9.2](#)

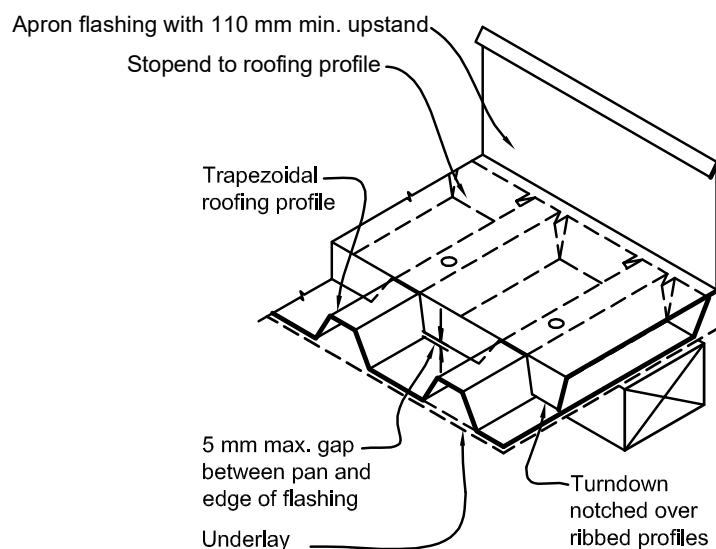

Note: (1) *Apron flashing* cover varies according to the *wind zone* (refer to refer to [Table 4.5.1.1](#)).

Roof claddings

8.4.9.3 When fixing *flashings* to the structure, use screws as for roofing (refer to Subsection [8.4.6](#)).

8.4.9.4 When fixing *flashings* to other *flashings* or to roofing use:

- a) for galvanized steel, 4 mm diameter monel metal or stainless steel rivets, where compatible as per Table 21; and
- b) for aluminium-zinc-magnesium coated steel, 4 mm diameter aluminium rivets; and
- c) for aluminium, 4 mm diameter aluminium rivets.

COMMENT: The use of stainless steel fixings is not recommended by steel manufacturers for use with coated steel, in severe marine and industrial environments, as they are considered to cause deterioration.

8.4.9.5 *Flashing* joints, including expansion joints where required, shall be in accordance with [Subsection 4.4.4](#) and as shown in [Figure 4.4.4.1](#).

8.4.9.6 Where end-laps are required in *flashings*, form these as shown in [Figure 4.4.4.1](#) and, before joining the two parts, apply an 8 mm diameter bead of neutral cure sealant complying with:

- a) Type F, Class 20LM, or 25LM of ISO 11600; or
- b) low modulus Type II Class A of Federal Specification TT-S-00230C.

8.4.9.7 The *roof* shall be flashed using details shown below:

- a) ridge to hip as shown in [Figure 8.4.9.7A](#); and
- b) *apron flashing* and change in pitch as shown in [Figure 8.4.9.7B](#); and
- c) *eaves flashing* as in [Figure 8.4.9.7C\(a\)](#) required for all roofs under 10° pitch and soffit widths less than 100 mm; and
- d) roof/wall ridge as shown in [Figure 8.4.9.7C\(b\)](#); and
- e) ridge and hip as shown in [Figure 8.4.9.7D](#); and
- f) *barge flashings* as shown in [Figure 8.4.9.7E](#); and
- g) *apron flashing* – parallel flashing to profile as shown in [Figure 8.4.9.7F](#).

COMMENT: Reduced cover for *barge* and *apron flashings* may be applicable for specifically designed *roofs* in low *wind zones*.

Refer to the New Zealand Metal Roof and Wall Cladding Code of Practice for additional guidance on ridge to hip flashings.

Roof claddings

Figure 8.4.9.7A: Ridge to hip flashings

Paragraph [8.4.9.7](#) and [Table 4.5.1.1](#)

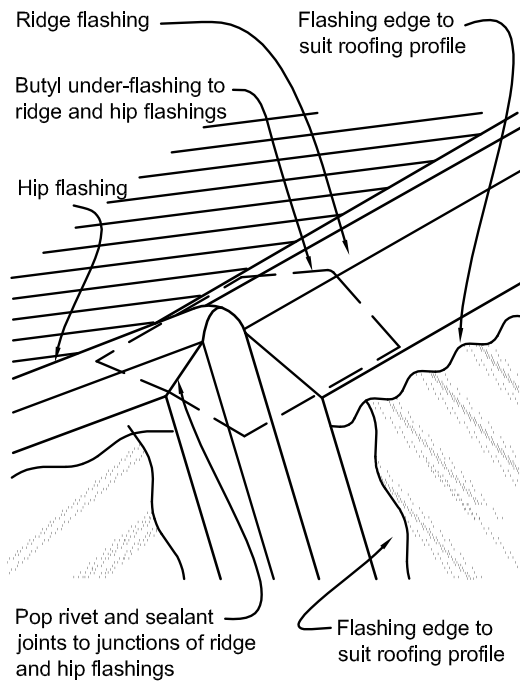

Notes:

- (1) Flashing cover varies according to the *wind zone* (refer to [Table 4.5.1.1](#)).
- (2) For other ridge-to-hip flashings, refer to the New Zealand Metal Roofing and Wall Cladding Code of Practice.

Figure 8.4.9.7B: Apron flashing and change in pitch for profiled metal

Paragraphs [4.5.3.2](#), [8.4.9.7](#), and [Table 4.5.1.1](#)

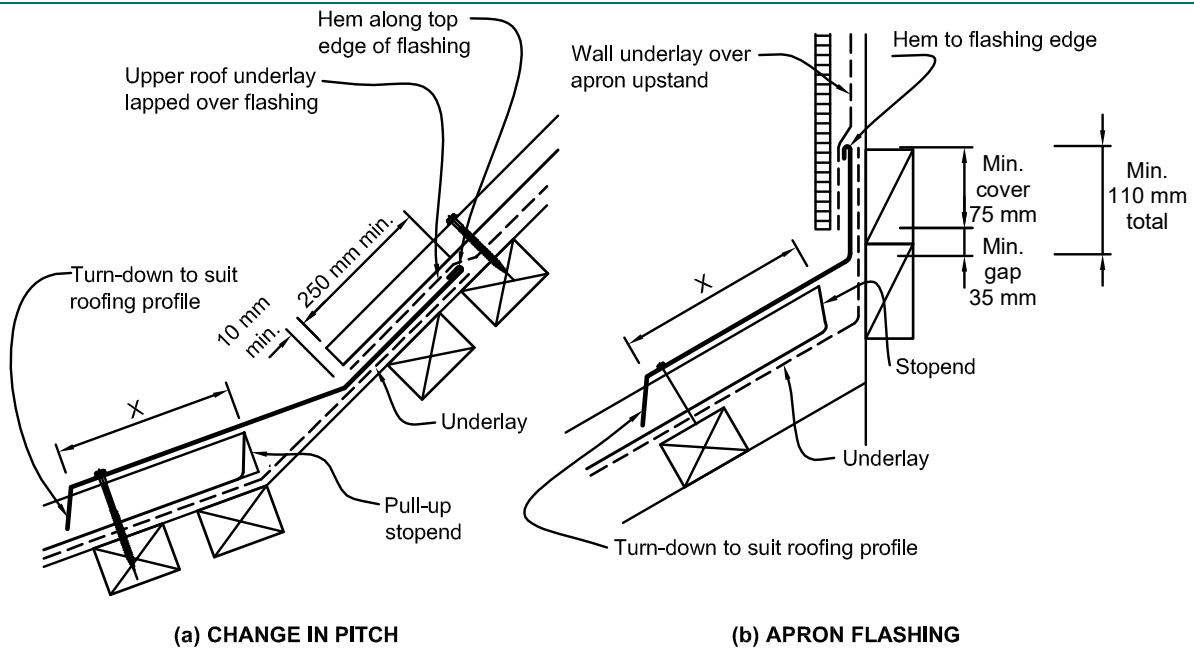

(a) CHANGE IN PITCH

(b) APRON FLASHING

Note: (1) Dimension X varies according to the *wind zone* (refer to [Table 4.5.1.1](#)).

Roof claddings

Figure 8.4.9.7C: Eaves and roof/wall ridge for profiled metal

Paragraphs [8.4.9.7](#), and [Table 4.5.1.1](#)

Eave flashing required where all of the following conditions are met:

- Roof slope less than or equal to 10°, and
- soffit width less than or equal to 100 mm, and
- wind zones are Very High or Extra High

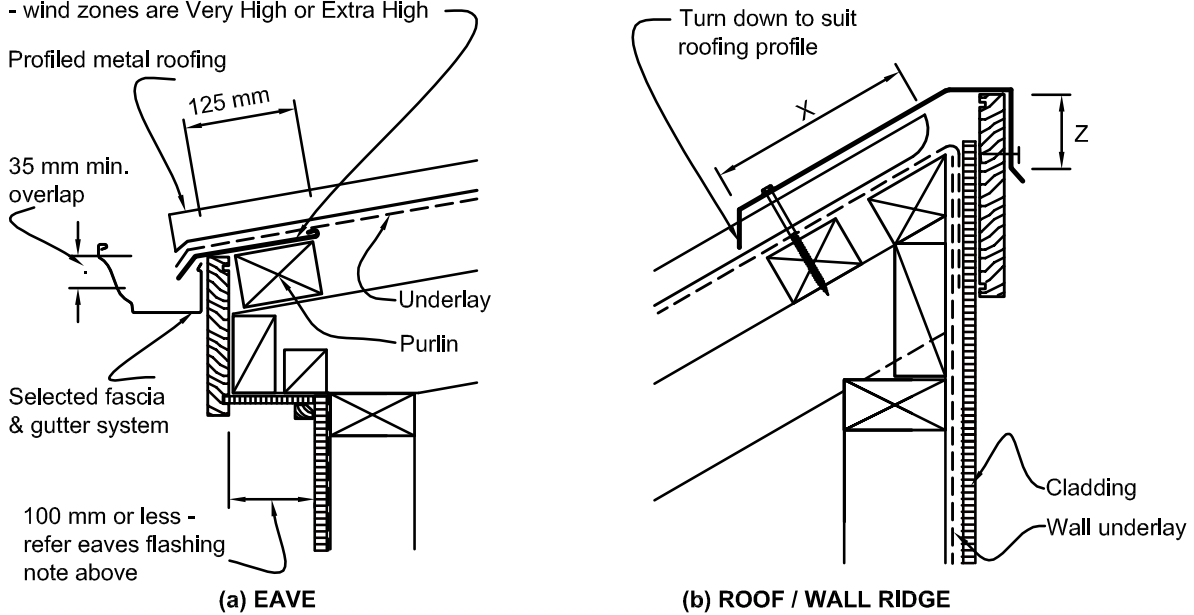

Note: (1) For dimensions X and Z, refer to [Table 4.5.1.1](#).

Figure 8.4.9.7D: Ridge and hip flashings for profiled metal

Paragraphs [4.5.3.1](#), [8.4.9.7](#), and [Table 4.5.1.1](#)

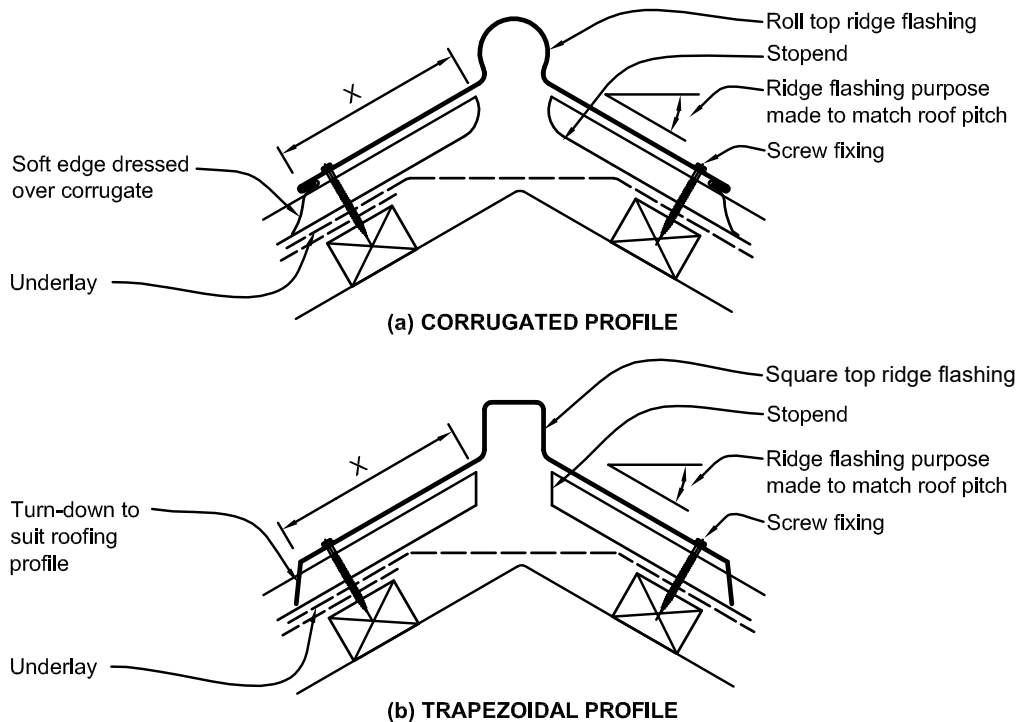

Note: (1) For dimension X, refer to [Table 4.5.1.1](#).

Roof claddings

Figure 8.4.9.7E: Barge flashings for profiled metal

Paragraphs [4.5.2.2](#), [4.5.4.2](#), [8.4.9.7](#), and [Table 4.5.1.1](#)

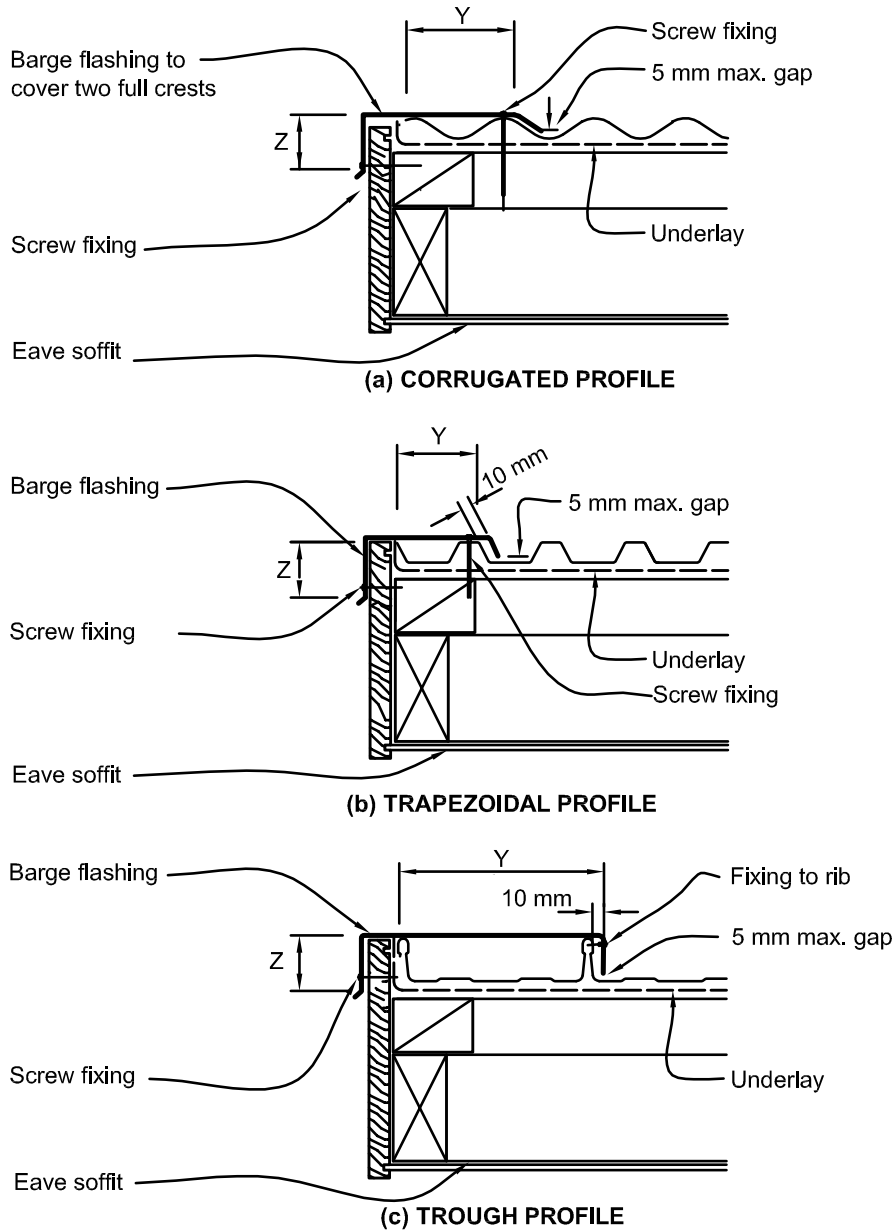

Note: (1) For dimensions Y and Z, refer to [Table 4.5.1.1](#).

Roof claddings

Figure 8.4.9.7F: Parallel apron flashings for profiled metal

Paragraphs [4.5.2.2](#), [8.4.9.7](#), and [Table 4.5.1.1](#)

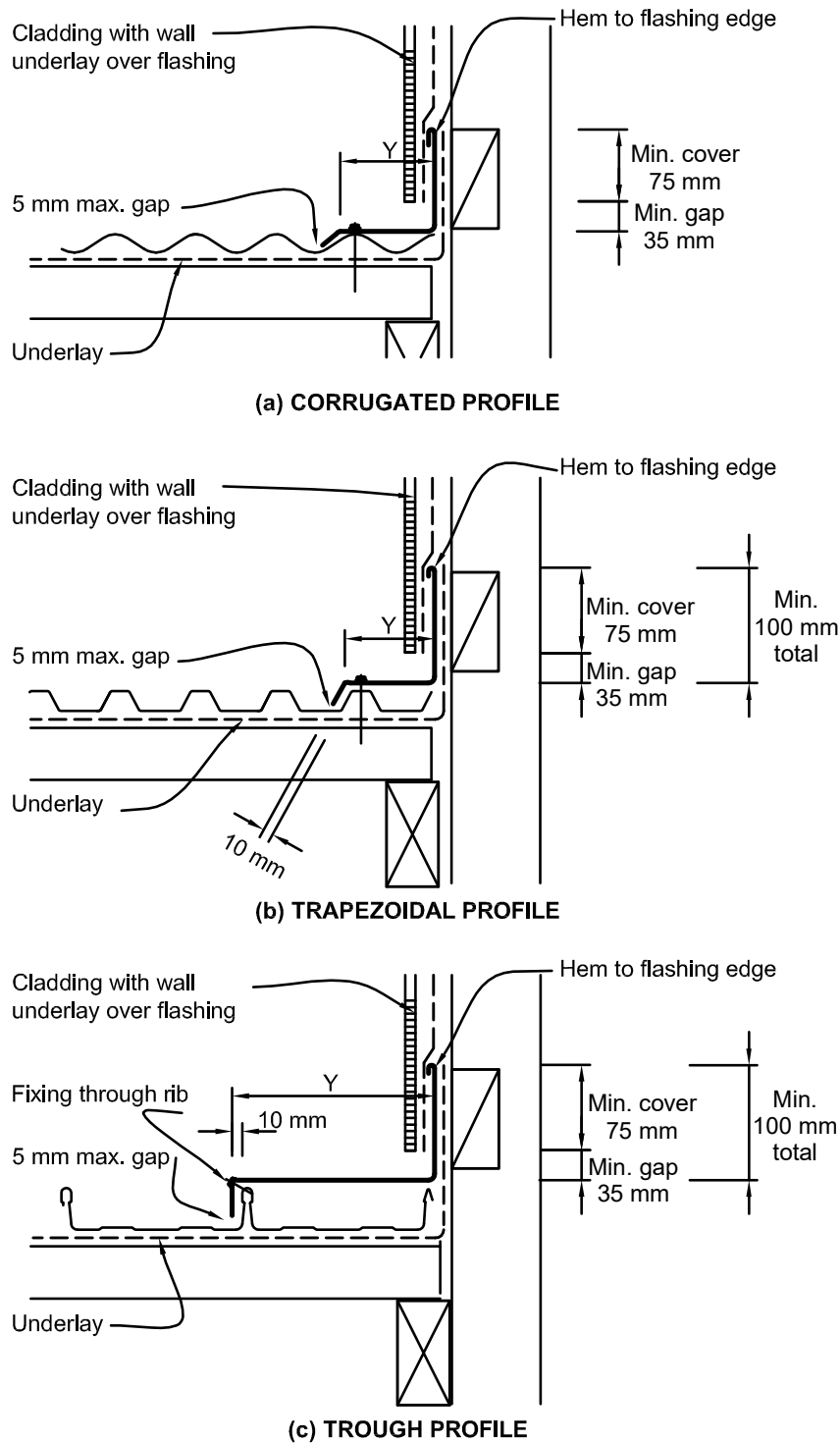

Note: (1) For dimension Y, refer to [Table 4.5.1.1](#).

Roof claddings

8.4.10 Stopends, turn-downs, and profile closures

8.4.10.1 The top ends of profiled metal *roof cladding* shall have *stopends* as shown in [Figure 8.4.10.1](#) for *trapezoidal* and *trough profile* metal *roof cladding*, where:

- the *roof pitch* is less than 25°; or
- the building is in a High/Very High/Extra High *wind zone*.

Figure 8.4.10.1: Profiled metal stopends

Paragraph [8.4.10.1](#) and [Figure 4.5.2.1](#)

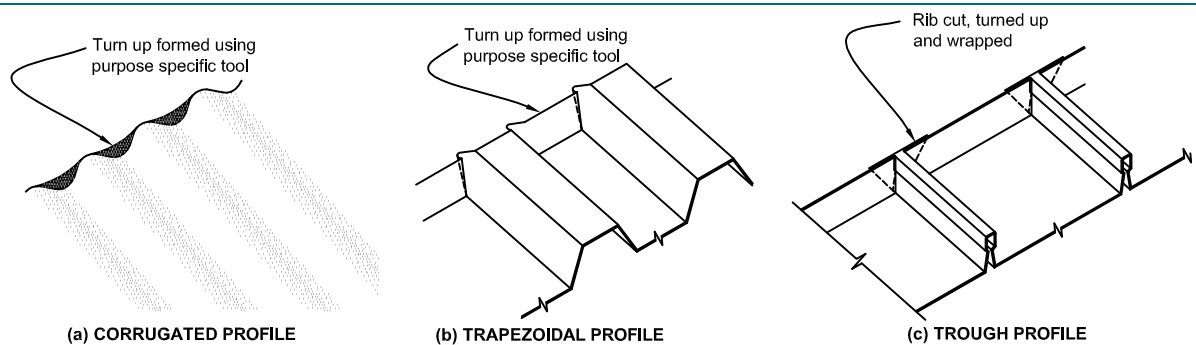

8.4.10.2 The lower ends of *trapezoidal* and *trough profile* roofing shall be turned down at gutters, where the *roof pitch* is less than 10°. The turn-down shall be 30° from the plane of the sheet.

COMMENT: Specific tools are available and should be used to turn up or turn down ends. Care should be taken to ensure the sheet does not split. Refer to the New Zealand Metal Roof and Wall Cladding Code of Practice for guidance on methods.

8.4.10.3 Preformed compressible seals shall not be used at the *eaves*.

COMMENT: Refer to the New Zealand Metal Roof and Wall Cladding Code of Practice for additional guidance on ridge to hip *flashings*.

8.4.11 Hidden, valley, and internal gutters

8.4.11.1 *Hidden gutters*, *valley gutters*, and internal gutters shall be in accordance with Subsection [8.1.4](#) and with Subsection [8.1.5](#) or [8.1.6](#) as appropriate.

8.4.11.2 Parallel *hidden gutters* shall be as shown in [Figure 8.4.11.2](#) and Subsection [8.1.6](#).

8.4.11.3 *Valley gutters* shall not change direction in plan, shall be in accordance with catchment areas shown in [Table 8.1.6.1](#), and shall be as shown in [Figure 8.4.11.3](#) and Subsection [8.1.6](#).

COMMENT: Refer to the New Zealand Metal Roof and Wall Cladding Code of Practice for additional guidance on sizing, materials and fixing.

8.4.11.4 Internal gutters shall be as shown in [Figure 8.4.11.4](#) and Subsection [8.1.5](#).

Roof claddings

Figure 8.4.11.2: Parallel hidden gutter for profiled metal

Paragraphs [8.1.6.1](#), [8.4.11.2](#), and [Table 4.5.1.1](#)

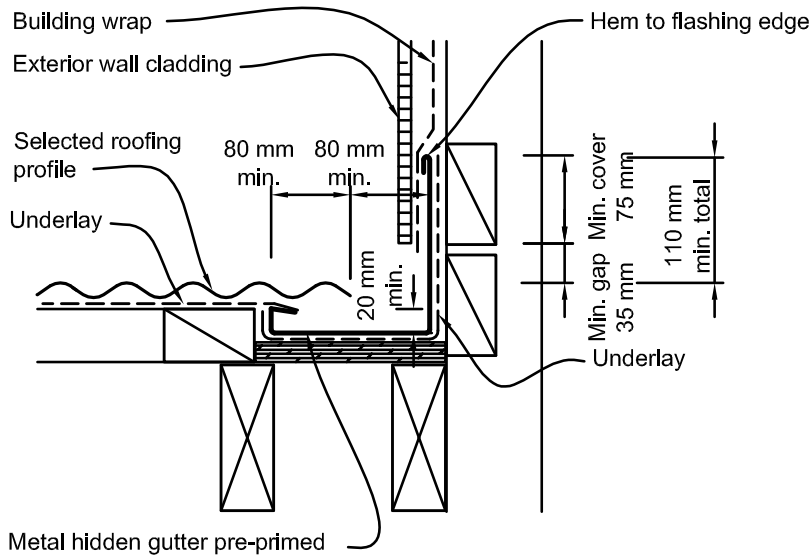

Note: (1) Where the gutter finishes within the length of the wall, step the lower part of the gutter out to 10 mm past the *cladding* line, while maintaining the required clearances, to allow the gutter to feed into the lower eaves gutter.

Figure 8.4.11.3: Valley gutters for profiled metal

Paragraphs [8.1.6.1](#) and [8.4.11.3](#)

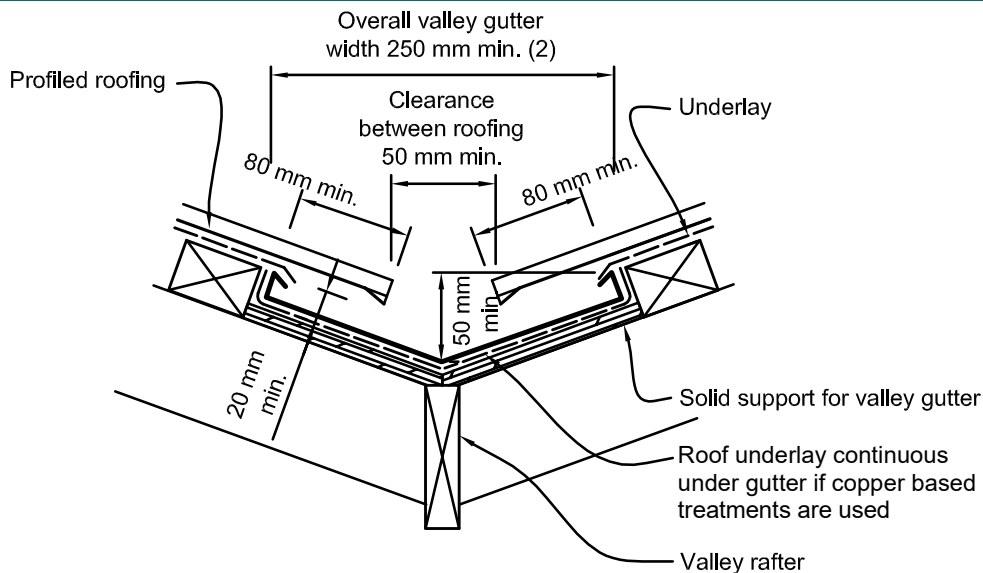

Notes:

(1) For the maximum *roof* catchment areas for *valley gutters*, refer to [Table 8.1.6.1](#).

(2) The minimum width of the *valley gutter* may be reduced to 160 mm, provided the *roof* catchment area is in accordance with [Table 8.1.6.1](#). In this case, the cover of *roof cladding* over the gutter shall be reduced to 60 mm to provide a clearance gap of 40 mm.

Roof claddings

Figure 8.4.11.4: Internal gutter for profiled metal

Paragraphs [8.1.5.1](#) and [8.4.11.4](#)

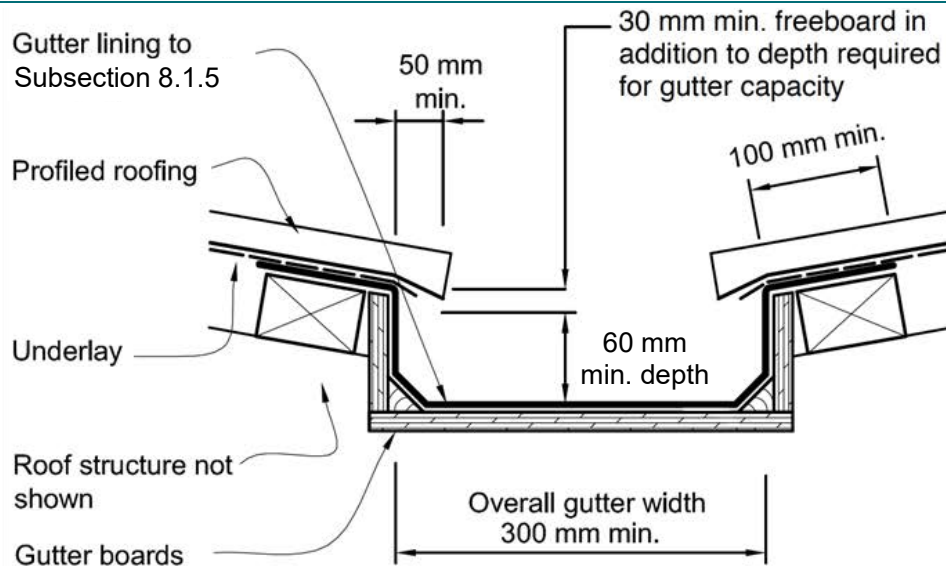

Notes:

- (1) Butyl rubber gutter lining is to comply with Subsection [4.2.10](#). Butyl cross joins in gutter are not permitted.
- (2) The internal gutter shall be sized to meet the requirements of Building Code clause E1 Surface Water for the particular *roof* catchment area. However, in no case shall the dimensions be less than those shown in this figure.
- (3) 1:100 gutter fall.
- (4) For gutter drainage, refer to Subsection [8.1.5](#).

8.4.12 Roof penetrations

- 8.4.12.1 The maximum length of profiled *roof cladding* above penetrations shall be as shown in [Table 8.4.12.1](#).
- 8.4.12.2 The edge of roofing penetrations over 200 mm wide shall be supported in either direction with additional *framing* as shown in [Figure 8.1.7.2A](#).
- 8.4.12.3 *Roof penetrations* shall be flashed as follows:
 - a) pipe penetrations up to 85 mm shall be flashed using an *EPDM boot flashing* as shown in [Figure 8.4.12.3A](#); and
 - b) pipe penetrations up to 500 mm shall be flashed using a *soaker flashing* and EPDM boot *flashing* as shown in [Figure 8.4.12.3B](#); and
 - c) rectangular penetrations up to 1200 mm wide shall be flashed using a *soaker type flashing* as shown in [Figure 8.4.12.3C](#).

COMMENT: Penetrations on lower pitched *roofs*, larger penetrations, or needing specialised complex *flashings* will require *specific design* to suit the particular circumstances. The New Zealand Metal Roof and Wall Cladding Code of Practice should be consulted for guidance.

Roof claddings

Table 8.4.12.1: Catchment areas for profiled metal

Paragraphs [8.1.7.2](#) and [8.4.12.1](#)

Penetration width (mm)	Maximum roof length above penetration Corrugated (m)	Maximum roof length above penetration Trapezoidal (m)	Maximum roof length above penetration Trough profile (m)
800 to 1200	4	8	16
600 to 799	6	12	18 ⁽¹⁾
400 to 599	8	16	18 ⁽¹⁾
0 to 399	12	18 ⁽¹⁾	18 ⁽¹⁾

Note: (1) Limited to 18 m as per the limitations of this acceptable solution.

Figure 8.4.12.3A: Flashing for small pipes

Paragraphs [8.4.12.3](#), [9.6.6.6](#), and [9.6.7.7](#)

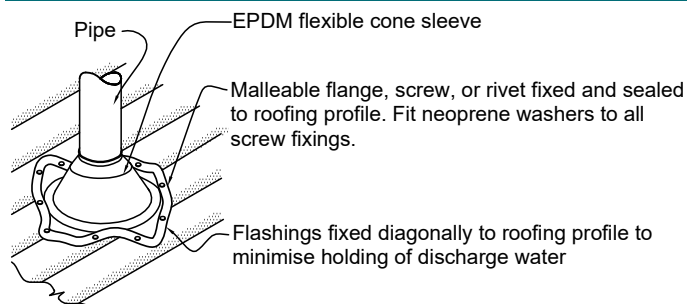

Notes: (1) The maximum *roof* pitch for this *flashing* is 45°. The minimum pitch is 10° if the base of the flange covers one or more complete troughs.

(2) This detail is suitable for pipes up to 85 mm in diameter.

Figure 8.4.12.3B: Soaker flashing for pipe penetrations

Paragraph [8.4.12.3](#) and [Table 4.5.1.1](#)

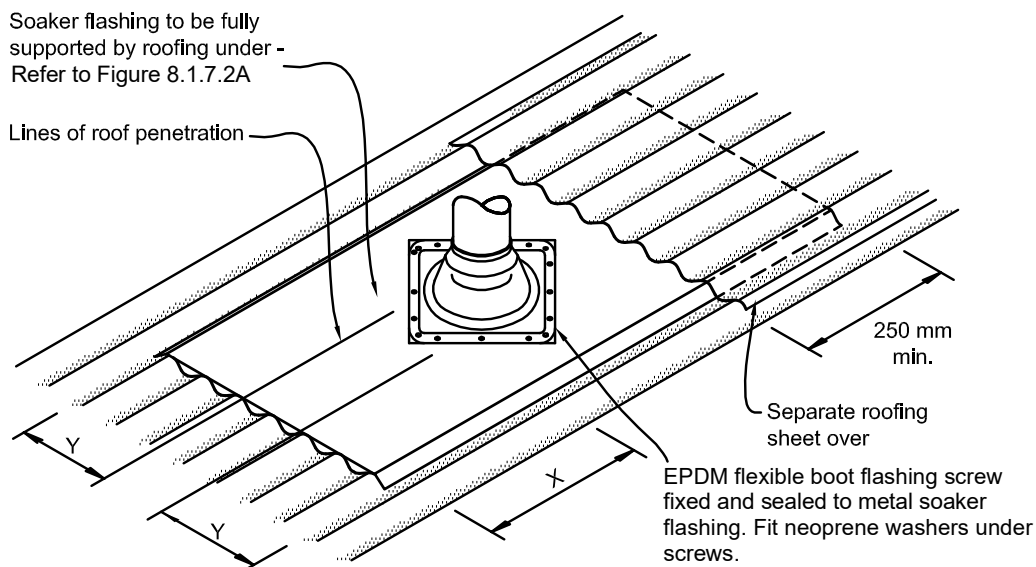

Notes: (1) This detail is suitable for pipes from 86 mm to 500 mm in diameter.

(2) This detail is suitable only for *roof* pitches of 10° or more.

(3) For dimensions X and Y, refer to [Table 4.5.1.1](#).

Roof claddings

COMMENT: EPDM and butyl rubber *membranes* are subject to damage when on trafficable *roof-decks*. A suitable wearing surface will help reduce such damage. Increases in slopes from the previous version recognise deflection tolerances in NZS 3604 and in-service loadings by *building* owners.

- 8.5.1.4 Closed-in *construction* spaces under *membrane roofs* and *decks* require adequate ventilation to prevent the accumulation of moisture under the membrane. Maintain a minimum gap of 20 mm between the underside of the substrate and any insulation, and for *membrane roofs* greater than 40 m², refer to manufacturer's details for *roof cavity vents* and/or substrate vent requirements.

8.5.2 Materials

- 8.5.2.1 Plywood shall be:

- a) a minimum of 17 mm complying with AS/NZS 2269; and
- b) at least CD Grade Structural plywood with the sanded C face upwards; and
- c) H3 with treatment type compatible with *membrane* and adhesives used, and kiln dried after treatment.

COMMENT: The compatibility of LOSP-treated timber must be checked with *membrane* suppliers.

If using plywood containing copper-based preservatives, check the compatibility of adhesives and *membranes* with copper with the product manufacturers.

- 8.5.2.2 Butyl rubber and EPDM rubber sheet and system components used for *membrane* roofing or *decks* shall:

- a) be a minimum thickness of:
 - i) 1 mm for roofing, or
 - ii) 1.5 mm for *decks* (refer to Subsection 8.1.5 for *membranes* to gutters); and
- b) comply with the following parts of Table 1 in ASTM D6134:
 - i) tensile strength, and
 - ii) elongation, and
 - iii) water absorption, and
 - iv) water vapour permeance, and
 - v) heat aging followed by tensile strength and elongation; and
- c) have adhesives, primers, seam tapes, and pre-formed components where supplied by the manufacturer that:
 - i) comply with BRANZ EM5, and
 - ii) are part of a complete system approved by the manufacturer or supplier of the *membrane*.

8.5.3 Installation

- 8.5.3.1 Plywood substrates must be dry when *membranes* are applied. The plywood and timber substructure must be a maximum moisture content of 20% when a *membrane* is adhered.

Roof claddings

COMMENT: This will generally require substrates to be covered to prevent rain wetting, or to be pre-primed to avoid moisture uptake.

Manufacturers' recommendations should be consulted, as some require a lower moisture content in order to validate guarantees.

8.5.3.2 Plywood substrates shall be fixed according to the following requirements:

- a) panels shall be laid with staggered joints (brick bond); and
- b) panels shall be laid with the face grain at right angles to the main supports; and
- c) supports in (b) shall be at 400 mm maximum centres; and
- d) the edge of sheets shall be supported with *dwangs* or *framing*; and
- e) external edges shall be chamfered with a minimum radius of 5 mm; and
- f) a 20 mm H3.2 triangular fillet shall be used at the base of any 90° upstand; and
- g) with 3 mm gaps between all sheets; and
- h) sheet fixings shall be 10g x 50 mm stainless steel countersunk head screws at:
 - i) 150 mm centres on edges, and
 - ii) 200 mm centres in the body of the sheets.

8.5.3.3 Seam tapes shall be used on all joints of:

- a) *roofs* or *decks* with falls less than 5° (1:12); and
- b) penetrations through the *membrane* where butyl or *EPDM* flashing is required; and
- c) *EPDM membrane*; and
- d) Butyl *membranes* that contain *EPDM*.

COMMENT: Coloured butyl *membranes* contain *EPDM*, which makes them more difficult to adhere properly. Seams should be aligned parallel to the fall of the deck to minimise ponding.

Where a penetration is made through the *membrane* subsequent to laying, the *flashing* should be installed by the applicator of the *membrane* system.

8.5.3.4 All joints in the plywood and junctions of plywood with other materials shall have 25 mm polyethylene release tape applied before application of the *membrane*.

8.5.4 Roof and deck drainage

8.5.4.1 *Membrane roofs* and *decks* shall be constructed to provide:

- a) falls as shown in [Figure 8.5.4.1A](#) and details in [Figure 8.5.4.1B](#), [Figure 8.5.6.1A](#), [Figure 8.5.6.1B](#), [Figure 8.5.6.1C](#), [Figure 8.5.6.1D](#), and [Figure 8.5.8.1](#); and
- b) a minimum set-down of 100 mm below an adjoining threshold as shown in [Figure 8.5.6.1D](#); and
- c) *membrane* upstands against all *walls*, *parapets*, or *enclosed balustrades* extending to a minimum level of 150 mm above *deck* level as shown in [Figure 8.5.6.1D](#); and
- d) water discharging either:
 - i) into a *roof* or gutter outlet with a minimum diameter of 75 mm as shown in [Figure 8.5.8.1](#) with an overflow as shown in [Figure 8.5.4.1B\(c\)](#), or
 - ii) into a *roof* or gutter outlet with a minimum diameter of 75 mm as shown in [Figure 8.5.8.1](#) with an extra outlet, with both outlets sized to take the full required capacity, or

Roof claddings

- iii) via a *scupper*, into a gutter, or rainwater head, as shown in [Figure 8.5.4.1B\(a\)](#), [Figure 8.5.4.1B\(b\)](#), and [Figure 8.5.4.1B\(d\)](#).

- 8.5.4.2 Gutters in *membrane roofs* and *decks* shall be formed with continuous butyl or EPDM strip complying with Subsection [4.2.10](#), with no cross-joints.

COMMENT: In addition to this paragraph, *membrane roof* and *deck* drainage must comply with Building Code clause E1 Surface Water. Acceptable Solutions E1/AS1 and E1/AS2 are options for achieving compliance.

Seams in gutters are particularly difficult to form at outlets through *enclosed balustrade walls*, and the risk of failure is high. Failure of a seam can result in damage to underlying *walls*.

8.5.5 Control joints

- 8.5.5.1 All *control joints* in the substrate shall be accommodated in the *membrane roof* design.
- 8.5.5.2 The design of *control joints* for *membrane* roofing is subject to *specific design* and is outside the scope of this acceptable solution.

8.5.6 Junctions

- 8.5.6.1 All junctions of *roof* or *deck* to *walls*, *parapets*, and *enclosed balustrades* shall be made weathertight using the following appropriate details:
- for external corners in upstand, see [Figure 8.5.6.1A](#); and
 - for internal corners in upstands, see [Figure 8.5.6.1B](#); and
 - for verges and eaves, see [Figure 8.5.6.1C](#); and
 - for junctions of *decks* and *walls*, see [Figure 8.5.6.1D](#); and
 - drainage details to Subsection [8.5.4](#).
- 8.5.6.2 Junctions of *membrane decks* or *walls* shall be formed as shown in [Figure 8.5.6.1D](#).
- 8.5.6.3 The bottom of the *wall cladding* above the *deck* or *roof* surface shall be sealed prior to fixing.

8.5.7 Penetrations

- 8.5.7.1 Penetrations through *membrane roofs* and *decks* shall be as shown in [Figure 8.5.7.1A](#) and [Figure 8.5.7.1B](#).
- 8.5.7.2 Fixing of posts for *handrails* into *membrane roofs* or *decks* is not covered by this acceptable solution.

COMMENT: Any fixing of posts into *membrane roofs* or *decks* will require *specific design*. The fixing of posts into tiles over a *membrane* is particularly risky and should be avoided.

8.5.8 Gutters

- 8.5.8.1 *Deck* gutters and internal outlets shall have dimensions to provide capacity that meets the requirements of Building Code clause E1 Surface Water, and shall be constructed as shown in [Figure 8.5.8.1](#).

COMMENT: Acceptable Solutions E1/AS1 and E1/AS2 provide means of calculating the capacity of internal gutters.

Internal outlets should have a dome-type cover to reduce risk of blockage, except where this could constitute a pedestrian hazard.

Roof claddings

Figure 8.5.4.1A: Falls in membrane roofs and decks

Paragraph [8.5.4.1](#)

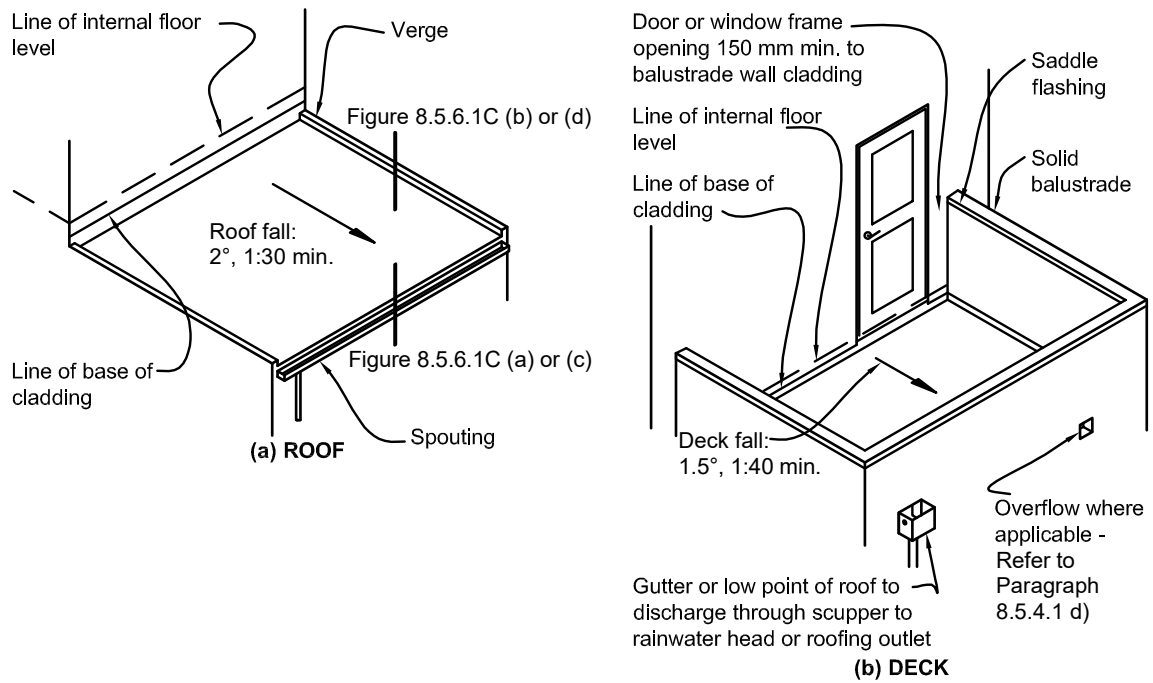

Notes:

- (1) For thresholds and clearances, refer to [Figure 8.5.6.1C](#).
- (2) For junction *saddle flashing*, refer to [Figure 6.2.3.1B](#).

Roof claddings

Figure 8.5.4.1B: Rainwater head and scupper opening in membrane

Paragraphs 8.1.5.2 and 8.5.4.1 and Table 4.5.1.1

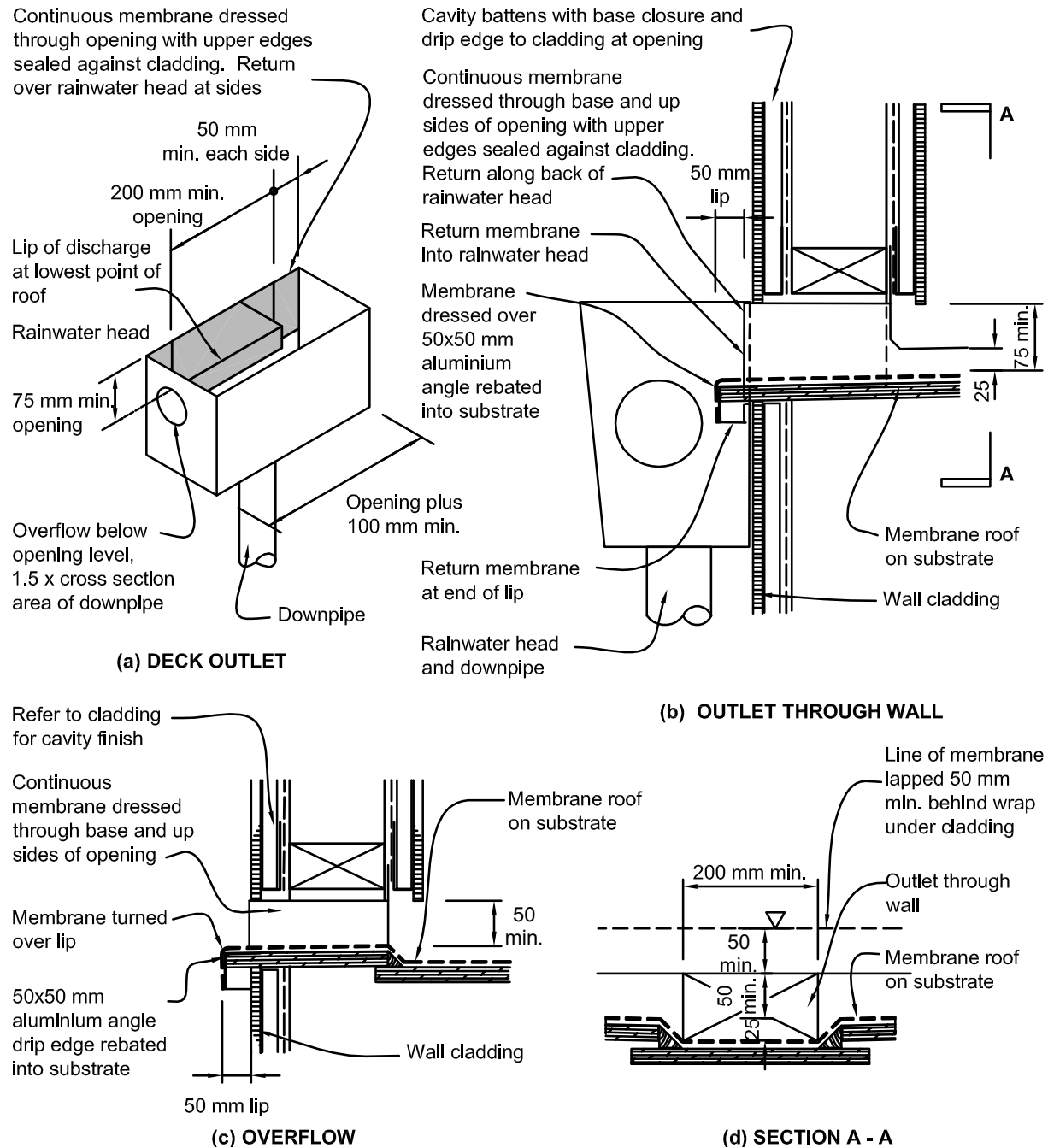

Notes:

- (1) Use preformed *scuppers* where provided by the *membrane* supplier.
- (2) External corners of the *scupper* opening are to be formed as shown in [Figure 8.5.6.1A](#).

Roof claddings

Figure 8.5.6.1A: External corner in upstand

Paragraphs [8.5.4.1](#), [8.5.6.1](#), [Figure 8.5.4.1B](#), and [Figure 8.5.7.1A](#)

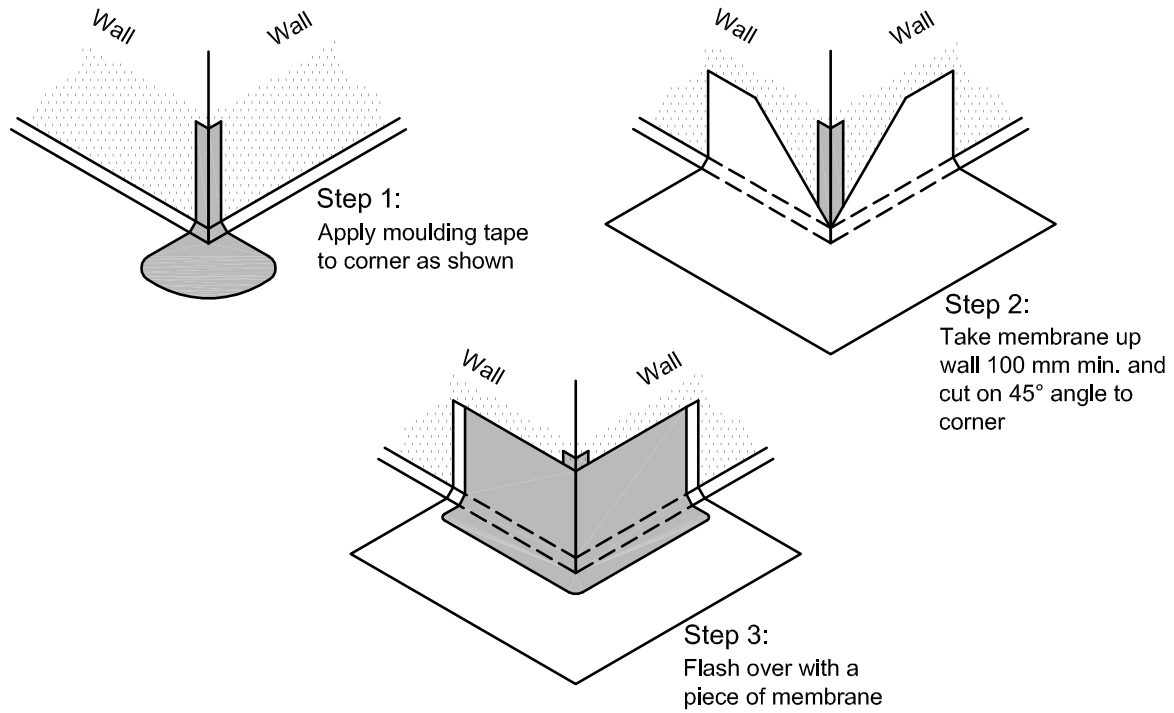
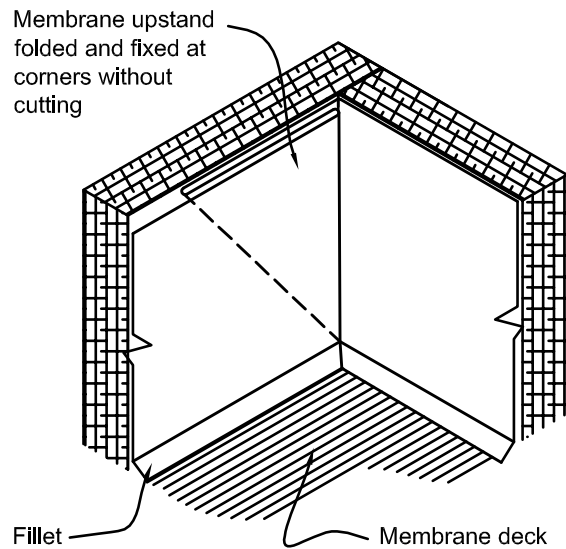

Figure 8.5.6.1B: Internal corner in upstand

Paragraphs [8.5.4.1](#), [8.5.6.1](#), [8.5.8.1](#), and [Figure 8.5.6.1D](#)



Roof claddings

Figure 8.5.6.1C: Verges in membrane

Paragraph 8.5.4.1, 8.5.6.1, 8.5.8.1, and Figure 8.5.4.1A

Membrane fixed under timber fillet and then folded round and overflashed by roof membrane

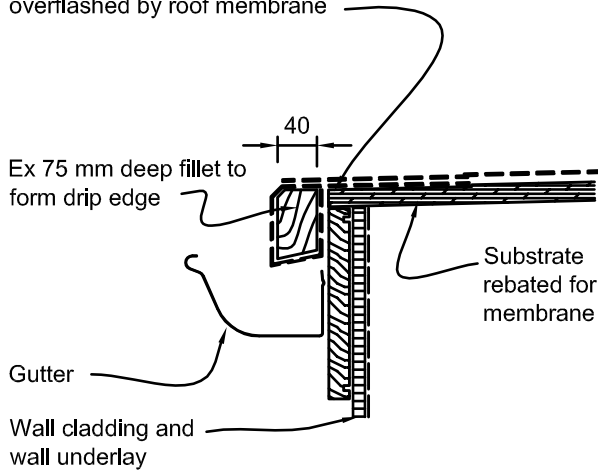

Membrane dressed over substrate and angle

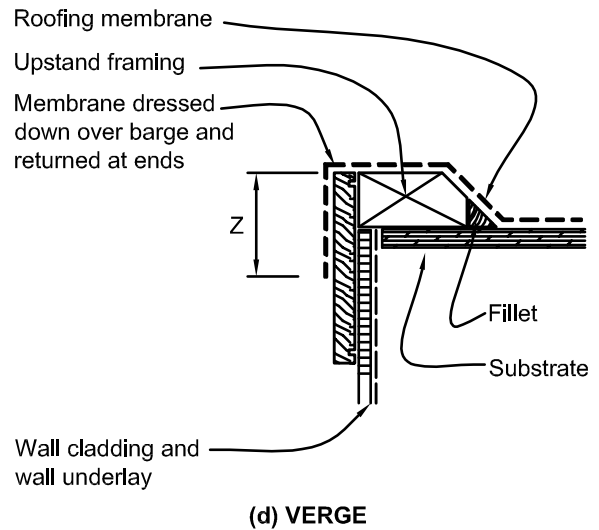
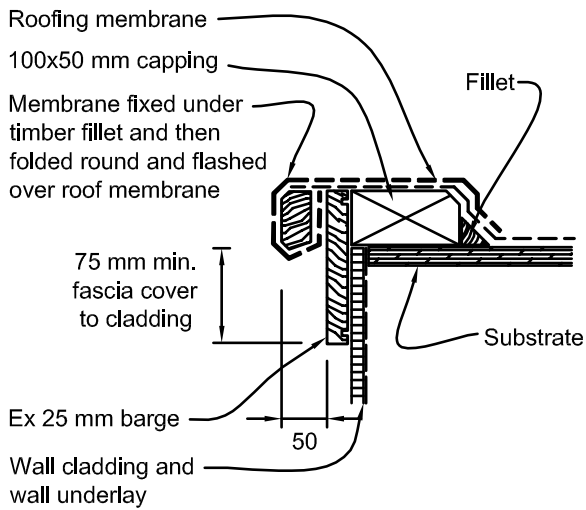
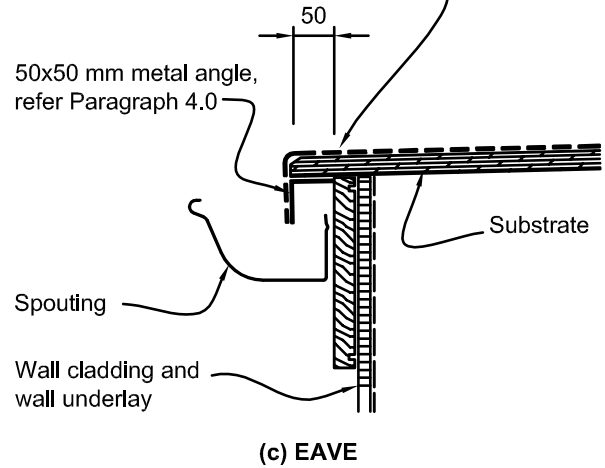

Note: (1) For dimension Z, refer to [Table 4.5.1.1](#).

Roof claddings

Figure 8.5.6.1D: Junctions with walls for membrane

Paragraphs 7.1.1.3, 8.5.4.1, 8.5.6.1, 8.5.6.2, Figure 8.5.8.1, and Table 4.5.1.1

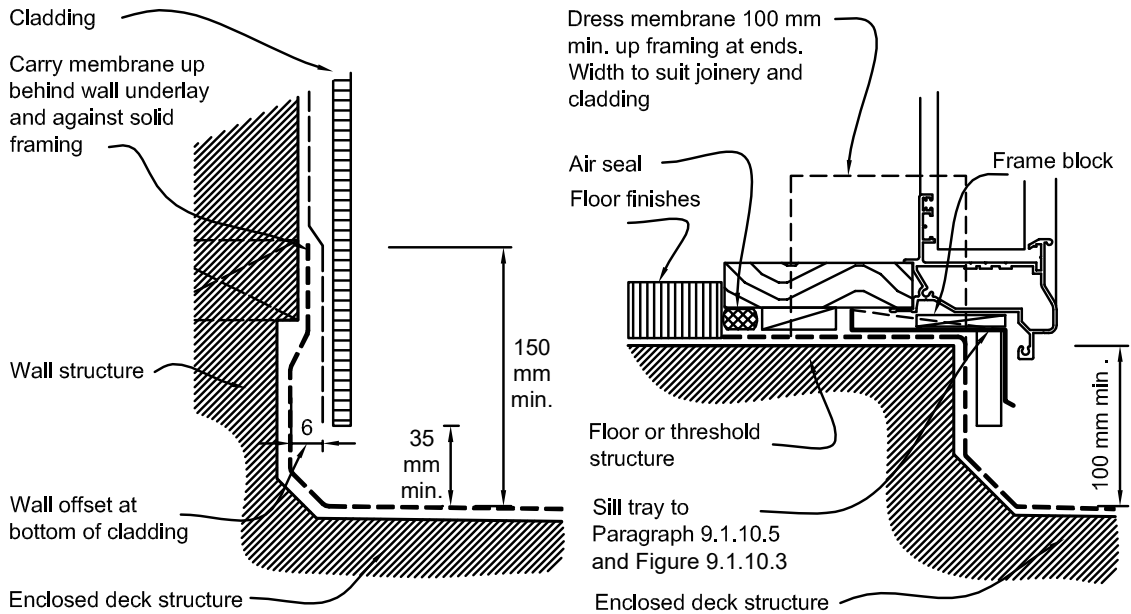

(a) DIRECT FIX CLADDING

(b) DIRECT FIX THRESHOLD AT OPENING

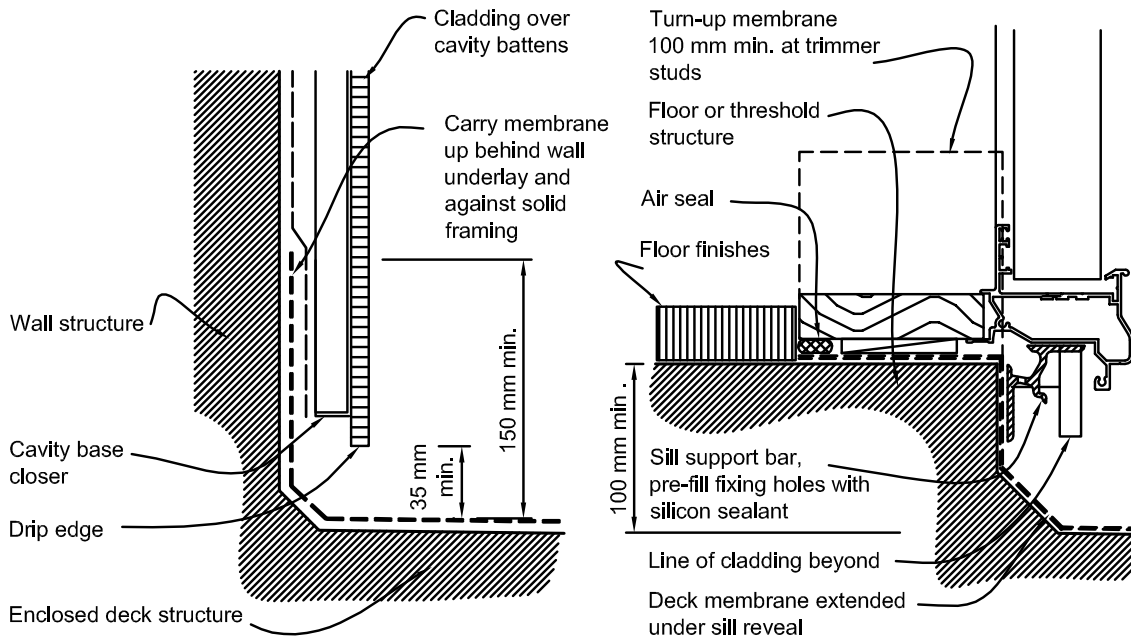

(c) CAVITY FIXED CLADDING

(d) CAVITY THRESHOLD AT OPENING

Notes:

- (1) Internal corners are to be formed as shown in [Figure 8.5.6.1B](#).
- (2) Dimensions are shown to the *membrane*. However, where there is an additional material applied over the *membrane*, all the dimensions shall apply to the highest level of the wearing surface.

Roof claddings

Figure 8.5.7.1A: Roofing penetration in membrane

Paragraph [8.5.7.1](#)

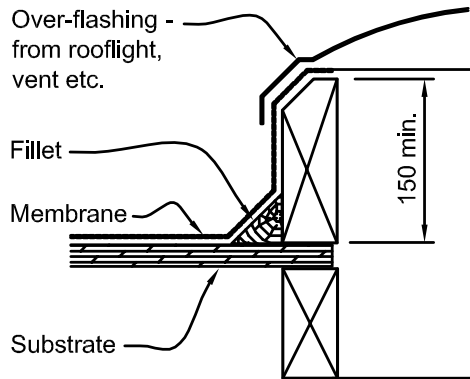

Notes:

- (1) This detail is suitable for a maximum penetration size of 1200 mm x 1200 mm.
- (2) External corners are to be formed as shown in [Figure 8.5.6.1A](#).

Figure 8.5.7.1B: Pipe penetration in membrane

Paragraph [8.5.7.1](#)

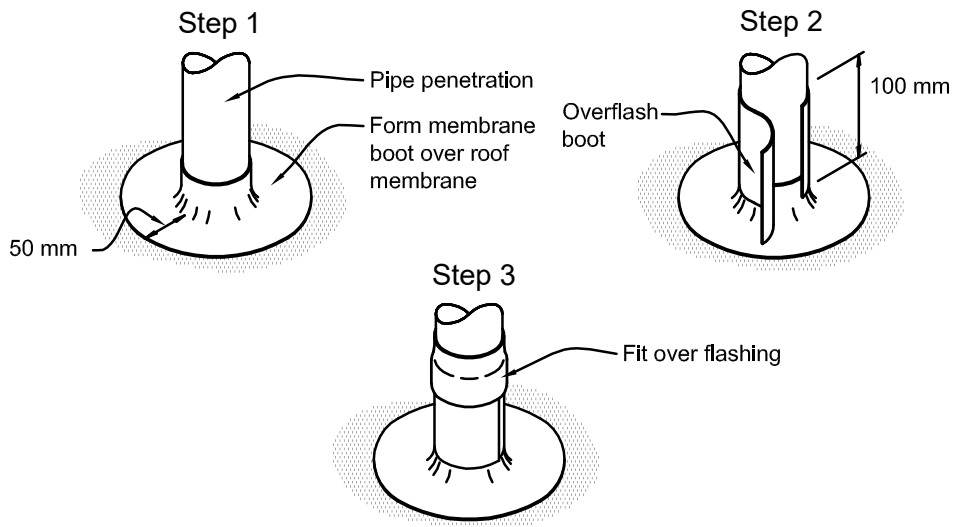

Roof claddings

Figure 8.5.8.1: Gutters and outlets in membrane

Paragraphs 8.1.5.2, 8.5.4.1, 8.5.8.1, and Table 4.5.1.1

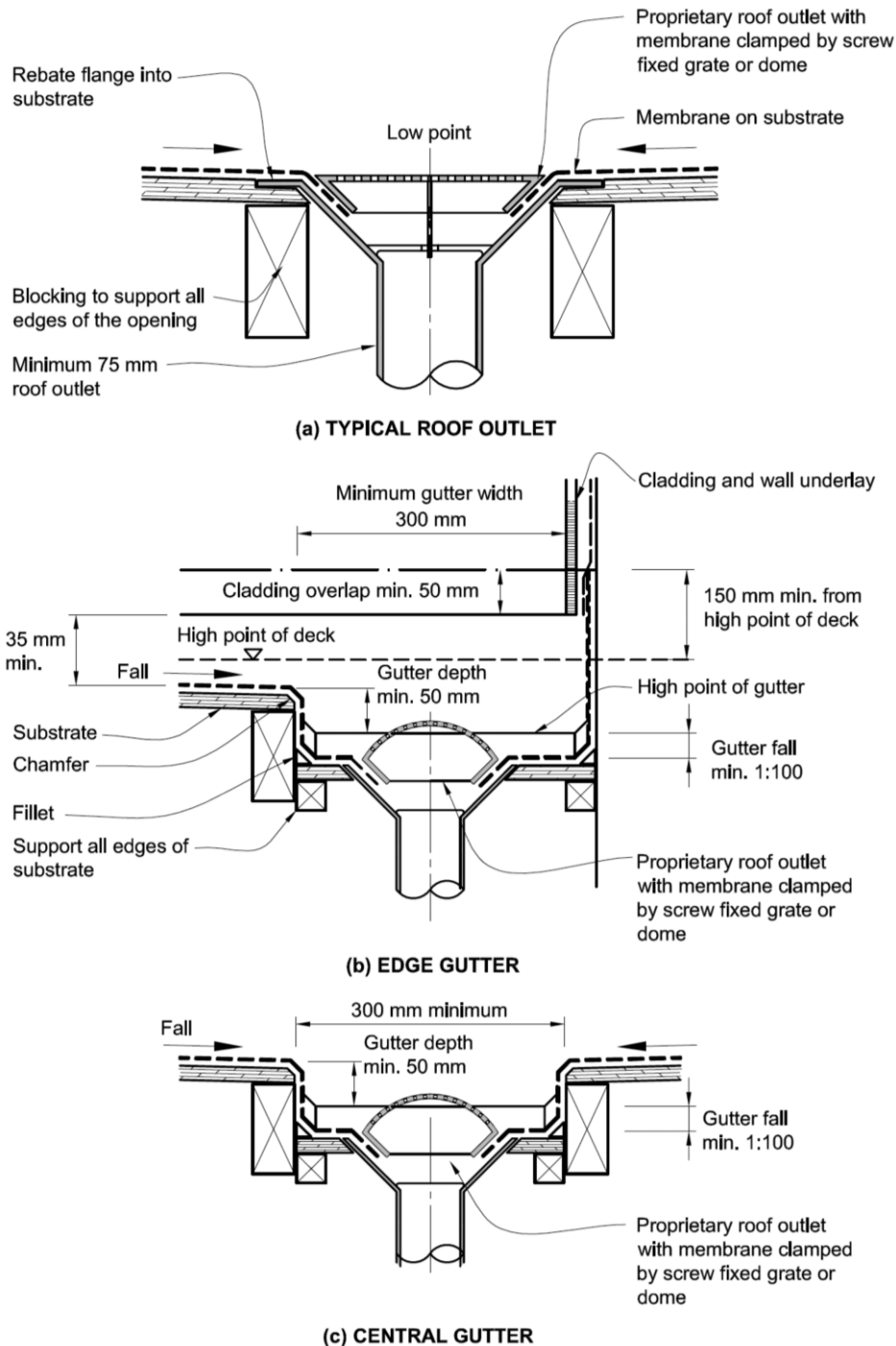

Note: (1) Gutters shall be sized to meet the requirements of Building Code clause E1 Surface Water for the particular *roof* catchment area. However, in no case shall the dimensions be less than those shown in this figure. A freeboard allowance is not required in addition to the gutter capacity required to meet clause E1 where gutters are *constructed* to comply with details (b) or (c), the *membrane roof* or *deck* has at least a 30 mm fall into the gutter channel, and all *membrane* perimeter details comply with [Figure 8.5.6.1B](#), [Figure 8.5.6.1C](#), [Figure 8.5.6.1D](#), and [Figure 8.5.8.1\(b\)](#).

Wall claddings

Part 9. Wall claddings

9.1 Demonstrating compliance

9.1.1 Overview

9.1.1.1 This part contains provisions for *wall cladding systems*.

9.1.1.2 *Wall cladding systems* in this part include:

- a) *masonry veneer* in Section [9.2](#); and
- b) *stucco* in Section [9.3](#); and
- c) timber weatherboards in Section [9.4](#); and
- d) fibre cement weatherboards in Section [9.5](#); and
- e) profiled metal *wall claddings* in Section [9.6](#); and
- f) fibre cement sheet in Section [9.7](#); and
- g) plywood sheet in Section [9.8](#); and
- h) *EIFS* in Section [9.9](#).

9.1.1.3 [Table 3.1.2.1](#) lists *wall cladding systems* that shall be used for *buildings* with varying *risk scores*. The method of establishing the level of risk associated with the use of a specific wall cladding is given in Section [3.1](#). Based on this *risk score*, a *wall cladding* may require the inclusion of a *drained cavity* as described in Subsection [9.1.7](#).

9.1.1.4 *Claddings* in Extra High *wind zones* require:

- a) rigid *underlays* in accordance with Paragraphs [9.1.6.2](#) and [9.1.6.4](#); and
- b) *drained cavities* in accordance with Subsection [9.1.7](#); and
- c) *hooks and hems on flashing upstands*, and additional 25 mm upstand height as required by Paragraph [4.4.3.4](#).

9.1.1.5 *Dwangs* shall be at a maximum of 1350 mm centres generally and maximum 480 mm centres for *direct-fixed* vertical weatherboard profiles, and vertical metal corrugated and symmetrical *trapezoidal claddings*.

9.1.1.6 Garage spaces within, or attached to, the *building* envelope shall have:

- a) openings provided with a 50 mm minimum total level change between the interior and the exterior paving; and
- b) provision to drain water away from the threshold of the opening; and
- c) rigid *wall underlays*, to [Table C.2.1.1](#), where external garage walls are unlined; and
- d) linings to garage walls adjoining habitable spaces; and
- e) weather resisting garage doors; and
- f) window and door details (where included) to Sections [9.2](#), [9.3](#), [9.4](#), [9.5](#), [9.6](#), [9.7](#), [9.8](#), and [9.9](#).

COMMENT: Methods for achieving the required step in Paragraph 9.1.1.6 a) may include:

1. a 50 mm difference in *finished ground level* adjacent to the opening; or
2. a raised threshold at the opening; or
3. concrete nibs at the opening.

9.1.2 Bottom of cladding

9.1.2.1 Separations, clearances to ground level, and overlaps shall be as shown in [Figure 9.1.2.1](#) and [Table 9.1.2.1](#).

Wall claddings

9.1.2.2 Clearances to *roof claddings* and *membrane decks* shall be minimum 35 mm (refer to [Table 4.5.1.1](#) and [Figure 7.5.4.1](#)).

9.1.2.3 Clearances shall be measured to:

- a) the finished plane of any adjacent horizontal surface; or
- b) the top surface of any adjacent sloped or horizontal *apron flashing*.

COMMENT: This keeps the bottom edge of the *cladding* dry, and allows cleaning and painting of the bottom surfaces.

Figure 9.1.2.1: Levels and garage openings

Paragraphs [9.1.2.1](#), [9.1.2.4](#), [9.1.2.7](#), and [9.2.5.2](#)

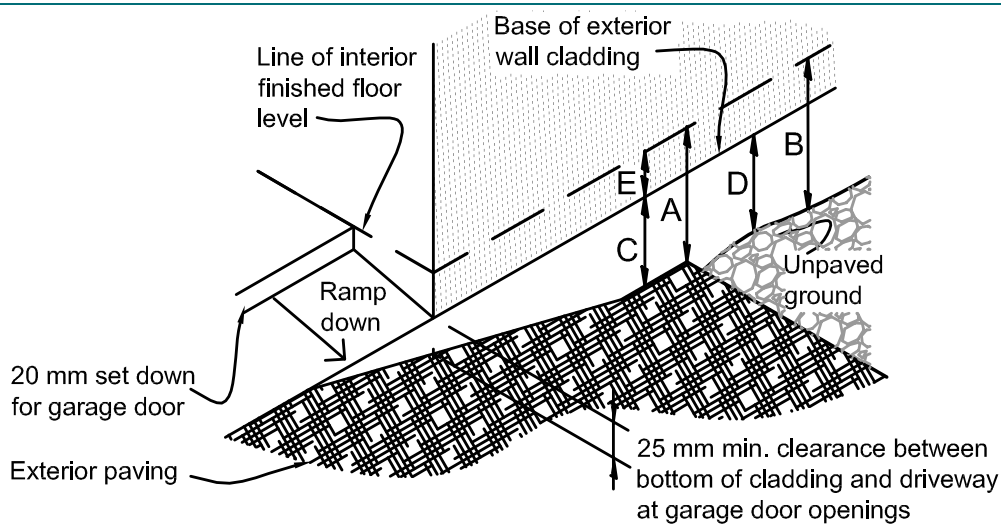

Table 9.1.2.1: Minimum clearances for timber

Paragraphs [9.1.2.1](#), [9.1.2.4](#), [9.1.2.6](#), [9.1.2.7](#), and [9.1.2.8](#)

Floor type	Cladding material	Cladding type	Minimum clearance (mm)
Concrete slab	Masonry veneer	A	100
		B	150
	Other claddings	A	150
		B	225
		C	100
Timber floor	Masonry veneer	D	175
		E	50
	Other claddings	(1)	(1)
		C	100
		D	175
		E	50 ⁽²⁾

Notes:

(1) Refer to NZS 3604 for requirements.

(2) *Cladding* to extend minimum 50 mm below bearer or lowest part of timber floor *framing*.

Wall claddings

- 9.1.2.4 Concrete slab levels shall be set to allow reinstatement of final landscaped ground levels as outlined in [Figure 9.1.2.1](#) and [Table 9.1.2.1](#).

COMMENT: NZS 3604 may require greater ground clearances depending on floor type and materials. The likely final landscaped ground levels are to be taken into account when planning foundations and earthworks to avoid reductions to the minimum ground clearances in the finished *building*.

- 9.1.2.5 For *masonry veneer claddings*, the height of the floor slab above *finished ground level* shall be in accordance with [Figure 9.2.5.6A](#) and as shown in [Table 9.1.2.1](#).

- 9.1.2.6 For the bottom of *wall claddings* for concrete ground slabs (except for *masonry veneer*), at concrete slab level, the base of the *cladding system* shall be as shown in [Table 9.1.2.1](#), and:

- a) finish a minimum of:
 - i) 100 mm above a paved surface, or
 - ii) 175 mm above finished unpaved surface; and
- b) overlap the concrete slab by 50 mm; and
- c) be offset horizontally by a minimum of 6 mm for *direct fixed claddings* to prevent capillary action.

- 9.1.2.7 For garages and openings to garages, refer to Paragraph [9.1.1.6](#), [Figure 9.1.2.1](#), and [Table 9.1.2.1](#) for overall level change requirements.

COMMENT: This paragraph does not apply to garages that are detached outbuildings.

- 9.1.2.8 For bottom of *wall claddings* for timber floor *framing*,

- a) suspended timber floors shall meet the requirements of NZS 3604; and
- b) clearances from paved and unpaved surfaces to the wall *framing* shall be in accordance with NZS 3604 and [Table 9.1.2.1](#); and
- c) the base of the *cladding system* shall:
 - i) overlap the timber floor structure by 50 mm minimum, and
 - ii) for walls with *direct fixed claddings*, be offset horizontally from a concrete foundation *wall* by a minimum of 6 mm, and
 - iii) have no direct connection between subfloor spaces and *drained cavities*.

COMMENT: Where *claddings* require *drained cavities*, care must be taken to ensure air from the subfloor space cannot enter the cavity. This is important, as moisture levels in subfloor air can be high.

9.1.3 Barriers to airflow

- 9.1.3.1 *External walls* shall have barriers to airflow, in the form of:

- a) interior *linings* with all joints stopped for *wind zones* up to Very High; or
- b) rigid *underlays* (and *drained cavities*) for *buildings* in Extra High *wind zones* (refer to Paragraphs [9.1.6.2](#), [9.1.6.3](#), and [9.1.6.4](#)).

- 9.1.3.2 Where walls are not lined (such as attic spaces at gable ends), an air barrier complying with [Table C.2.1.1](#) shall be fixed to *framing* prior to fixing *cladding* or *cavity battens*.

- 9.1.3.3 For attached garages, *underlays* are required in accordance with:

- a) Paragraph [9.1.1.6\(c\)](#) where walls are unlined; and

Wall claddings

- b) Paragraph [9.1.3.1](#) where walls have internal linings.

COMMENT: The primary function of air barriers and *air seals* is to moderate airflows at junctions and inside the *wall cavity*.

Airflows in certain weather conditions encourage significant amounts of water to move along their path, and it is therefore important to manage airflow in *cavity walls* with barriers and *air seals*.

In the absence of internal *linings*, an air barrier is required to support wind pressures at locations such as gable ends and unlined garage spaces. Air pressure drop is not always across the internal *lining*, indicating the *wall underlay* acts as an air barrier as well.

9.1.4 Wall underlays to wall openings

- 9.1.4.1 Prior to window or door installation:

- a) flexible *wall underlay* shall be cut and dressed into all sides of openings as per [Figure 9.1.9.4](#) and [Figure 9.1.9.6](#); and
- b) *flexible flashing tape* shall be applied to head and sill *framing* as shown in [Figure 9.1.9.4](#) and [Figure 9.1.9.6](#). *Flexible flashing tape* shall:
 - i) comply with Parts 3.2 and 4 of ICBO Acceptance Criteria AC148, and
 - ii) be compatible with the *wall underlay*.

COMMENT: Dressing the *wall underlay* around the *framing* timber and providing a flexible *air seal* limits airflows around the window reveal.

The *flexible flashing tape* keeps any water that does get past the *cladding*, or through the joinery, from direct contact with the timber.

9.1.5 Air seals

- 9.1.5.1 Window, door and other penetration openings shall be provided with flexible *air seals* to minimise the risk of airflows carrying water into the *building wall*. The air seal shall be:

- a) provided between the reveal or frame and the wrapped opening (for example of use, refer to [Figure 9.4.6.1A](#)); and
- b) made of self-expanding polyurethane foam installed over a closed cell polyethylene foam (PEF) backing rod; or
- c) made of sealant installed over a closed cell polyethylene foam (PEF) backing rod. The sealant shall comply with:
 - i) Type F, Class 20LM or 25LM of ISO 11600, or
 - ii) low modulus Type II Class A of Federal Specification TT-S-00230C.

COMMENT: Some sealants can react with bitumen based *flashing* tape, preventing full curing of the sealant. Where necessary, consult sealant manufacturers for application requirements.

Backing rods are used for sealant and for self-expanding polyurethane foam as there is a danger foam will expand to the outside of the *wall* and form a moisture bridge to the interior.

For further information, refer to ASTM C1330 for backing rod material performance.

Wall claddings

9.1.6 Wall underlay

- 9.1.6.1 Flexible *wall underlays* shall be in accordance with [Table C.2.1.1](#), and shall:
- be run horizontally; and
 - have upper sheets lapped over lower sheets to ensure that direction of laps will allow water to be shed to outside of the *wall underlay*; and
 - be lapped not less than 75 mm at horizontal joints; and
 - be lapped not less than 150 mm over studs at vertical joints; and
 - extend 35 mm below bottom plate or bearer; and
 - be restrained from bulging into a *drained cavity* (refer to Paragraphs [9.1.1.5](#) and [9.1.7.10](#)).
- 9.1.6.2 Rigid *wall underlays*, in association with *drained cavities* (including *direct fixed* corrugated profiled metal), are required in Extra High *wind zones* (refer to [Table 3.1.2.1](#) and [Table C.2.1.1](#))
- 9.1.6.3 Rigid *underlays* are also required to *external walls* of attached garages that are unlined (refer to Paragraphs [1.1.1.3](#) and [9.1.1.6\(c\)](#)).
- 9.1.6.4 Rigid *wall underlays* shall be in accordance with [Table C.2.1.1](#) and shall:
- be minimum 7 mm H3 plywood or 6 mm fibre cement sheet; and
 - be installed with sheet edges fixed over solid framing; and
 - be over-fixed with a flexible *wall underlay* from [Table C.2.1.1](#) and installed as in Paragraph [9.1.6.1](#); and
 - have flexible *underlay* folded into opening reveals as in Paragraph [9.1.4.1\(a\)](#); and
 - have *cavity battens* at maximum 600 mm centres; and
 - be finish flushed with underside of bottom plate or bearer.

COMMENT:

- Some proprietary systems may not require the addition of a flexible underlay as per Paragraph 9.1.6.4(c).
- External air pressures in higher *wind zones* can transfer to interior linings, and exceed recommended loadings prescribed by some *lining* manufacturers. Rigid *underlays* will protect linings from undue air pressure loadings, and help ensure cavity depths are maintained for the proper functioning of the *drained cavity*.

9.1.7 Drained cavities

- 9.1.7.1 Based on the *risk score* for an *external wall* calculated as per Section [3.1](#), a *wall cladding* may require the inclusion of a *drained cavity*. Where a *drained cavity* is required, it shall meet the requirements of this subsection.

COMMENT: Cavities manage occasional ingress of water past the cladding, but should not act as gutters or drains."

- 9.1.7.2 Within this acceptable solution, *drained cavity* systems are limited to those where:
- cavity battens* are fixed, by the *cladding* fixings, to the *wall framing*; and
 - claddings* are fixed through the *cavity battens* into the *wall framing*; and
 - the *drained cavity* behind *claddings*, except in *masonry veneer*, is not vented at the top.
- 9.1.7.3 Systems where the *cladding* is fixed into the *cavity batten* only are outside the scope of this acceptable solution.

Wall claddings

- 9.1.7.4 Where a *drained cavity* is required, it shall:
- a) be installed over a *wall underlay*, either flexible or rigid, that:
 - i) complies with [Table C.2.1.1](#), and
 - ii) is fixed to *wall framing*; and
 - b) be formed using vertical *cavity battens*; and
 - c) restrict air movement between the *drained cavity*; and:
 - i) floor, *wall*, and *roof framing*, and
 - ii) attic *roof space*, and
 - iii) subfloor space; and
 - d) be drained and open to the exterior at the bottom of cavities; and
 - e) use vermin-proofing at the cavity base as per Paragraphs [9.1.7.5](#), [9.1.7.6](#), and [9.1.7.7](#) and [Figure 9.1.7.4A](#); and
 - f) where fixing between cavity battens is required, use *cavity spacers* as shown in [Figure 9.1.7.4B](#), or alternative *cavity spacers* in accordance with Paragraph [9.1.7.9](#).

COMMENT: Solid horizontal cavity spacers risk obstruction of air flow in cavities and risk bridging moisture across the cavity.

Figure 9.1.7.4A: Cavity base closer/vermin proofing

Paragraphs [9.1.7.4](#), [9.1.7.5](#), and [9.1.10.2](#)

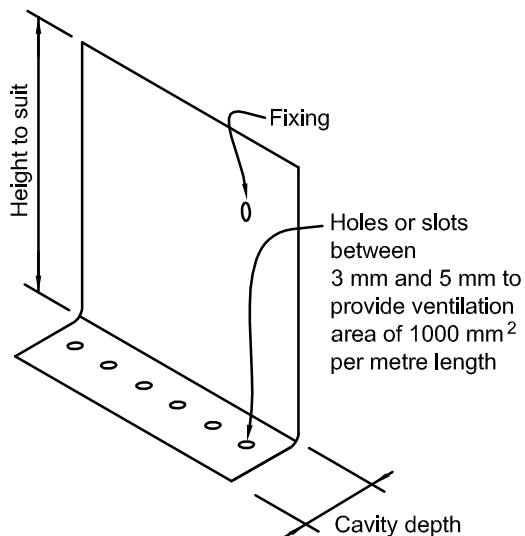

Note: (1) This detail is to be used in *drained cavities* at the base of *walls* and above window head and inter-storey *flashings*.

Wall claddings

Figure 9.1.7.4B: Cavity spacers

Paragraph 9.1.7.4

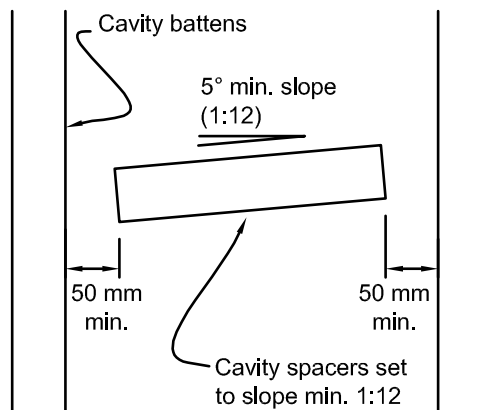

Note: (1) The spacing of *cavity spacers* will vary to suit individual *cladding* fixings.

- 9.1.7.5 Vermin-proofing shall be provided above window and door heads and at the base of the *drained cavity*. [Figure 9.1.7.4A](#) provides one example of an appropriate cavity closer.
- 9.1.7.6 Where vermin-proofing material is not readily accessible or replaceable, aluminium, stainless steel, or uPVC shall be used in accordance with Section [4.2](#).
- 9.1.7.7 Vermin-proofing shall:
- a) provide holes or slots between 3 mm and 5 mm; and
 - b) provide an area of opening of 1000 mm² per lineal metre of *wall*; and
 - c) be positioned to allow a minimum *drip edge* to the *wall cladding* of:
 - i) 10 mm at the base of walls, and
 - ii) 15 mm above window and door head *flashings*.

COMMENT: It is important the openings in vermin-proofing are kept clear and unobstructed in order to maintain draining and venting of the cavity. The closure shown is only one option for vermin-proofing. Provided openings are as specified, other dimensions can vary, so allowing the use of other shapes such as channels and right-angles.

- 9.1.7.8 *Cavity battens* shall:
- a) be nominal 20 mm (between limits of 18 mm and 25 mm in thickness); and
 - b) be a minimum 45 mm wide; and
 - c) be fixed, by the *cladding* fixings, through the *wall underlay* into the *framing*; and
 - d) if timber, comply with B2/AS1; and
 - e) if polystyrene, comply with Paragraph [9.9.2.2](#) and be protected from any incompatible vapours from timber treatment.
- 9.1.7.9 *Cavity battens* and/or cavity spacers that comply with E2/VM1 for a Class 1 *cladding system*, meet B2/AS1, and permit air circulation are allowed. The Class 1 test must include a horizontal *cladding* joint supported on cavity spacers of a proposed type.
- 9.1.7.10 Where *stud* spacings are greater than 450 mm, and flexible *wall underlays* only are used, an intermediate means of restraining the flexible *wall underlay* and insulation from bulging into the *drained cavity* shall be installed. Acceptable means of achieving this are by using:
- a) 75 mm galvanized mesh or wire galvanized in accordance with AS/NZS 4534; or

Wall claddings

- b) polypropylene tape or galvanized wire at 300 mm centres fixed horizontally and drawn taut; or
- c) vertical cavity battens at 300 mm centres maximum.

9.1.8 Penetrations

- 9.1.8.1 Window penetrations through cavities shall meet the requirements of Sections [9.2](#), [9.3](#), [9.4](#), [9.5](#), [9.6](#), [9.7](#), [9.8](#), and [9.9](#).
- 9.1.8.2 Where penetrations of the *wall cladding* are wider than the *cavity batten* spacing, allowance shall be made for air flow between adjacent cavities by leaving a minimum gap of 10 mm between the bottom of the vertical *cavity batten* and the *flashing* to the opening.
- 9.1.8.3 Pipes and service penetrations shall be made weathertight by using methods shown in [Figure 9.1.8.3A](#) and [Figure 9.1.8.3B](#). *Flashing* tape shall comply with Subsection [4.2.12](#). Sealant shall comply with:
 - a) Type F, Class 20LM, or 25LM of ISO 11600; or
 - b) low modulus Type II Class A of Federal Specification TT-S-00230C.

COMMENT: Where possible, pipe penetrations, meterboxes and similar penetrations should be located in sheltered areas of the *building*, such as a porch, or be installed behind a weatherproof glazed panel.

Figure 9.1.8.3A: General pipe penetrations

Paragraphs [9.1.8.3](#), [9.9.7.2](#), and [Figure 9.9.7.1](#)

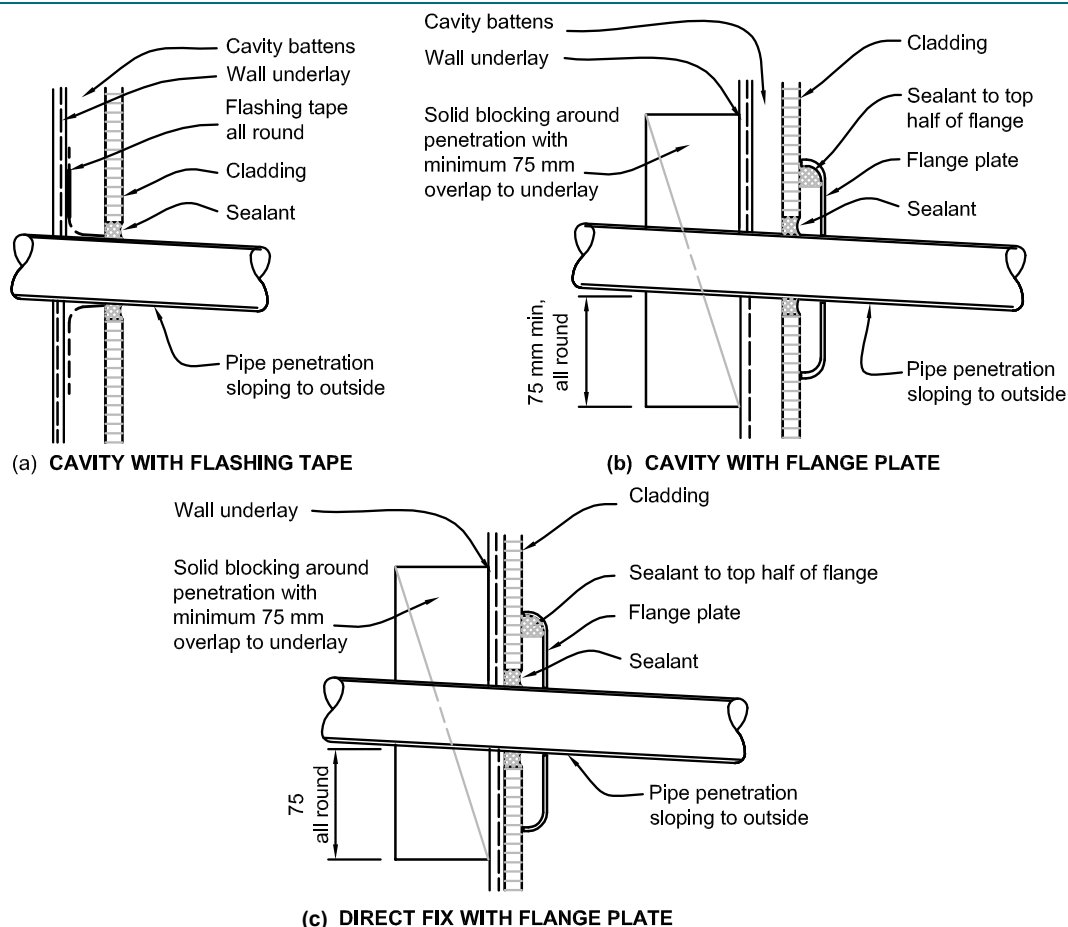

Wall claddings

Figure 9.1.8.3B: General meterbox and similar penetrations

Paragraphs [9.1.8.3](#), [9.6.6.7](#), and [9.6.7.8](#)

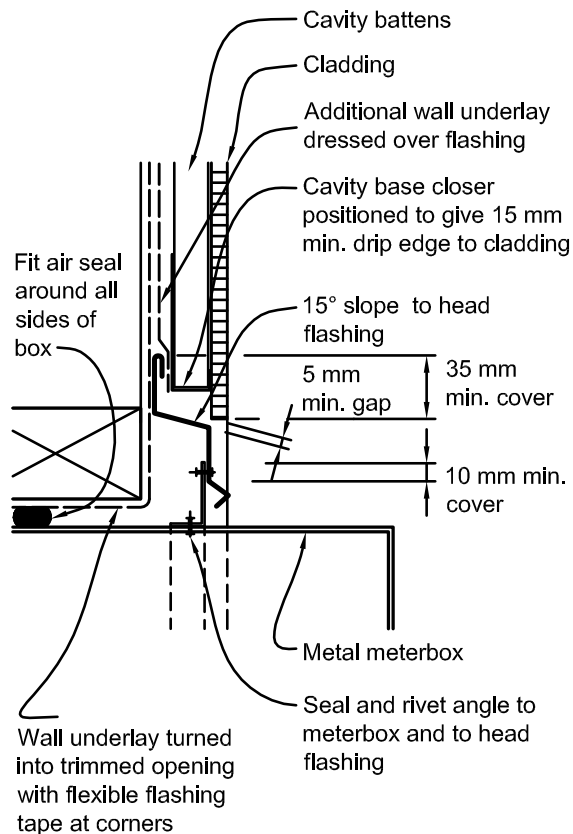

Notes:

- (1) Fix angle and seal to all sides of the box. At the side and base, *claddings* shall overlap angle by 10 mm minimum. Continuously seal *cladding* against angle.
- (2) This detail is suitable for other similar penetrations.

9.1.8.4 Inter-storey junctions in *claddings* over *drained cavities* shall be formed for *walls*:

- a) up to a maximum of two *storeys* or 7 metres in height, as shown for the specific *wall claddings* in Sections [9.3](#), [9.4](#), [9.5](#), [9.6](#), [9.7](#), [9.8](#), and [9.9](#); or
- b) over two *storeys* or 7 metres by using an inter-storey *flashing* bridging the *drained cavity* as shown in [Figure 9.1.8.4](#).

COMMENT: A *drained cavity* height is limited to manage the moisture handled by the cavity before it is directed to the outside.

Wall claddings

Figure 9.1.8.4: General inter-storey junction

Paragraphs [4.5.5.2](#), [9.1.8.4](#), [Figure 9.7.4.1E](#), [Figure 9.8.3.3](#), [Figure 9.9.3.4](#), and [Table 4.5.1.1](#)

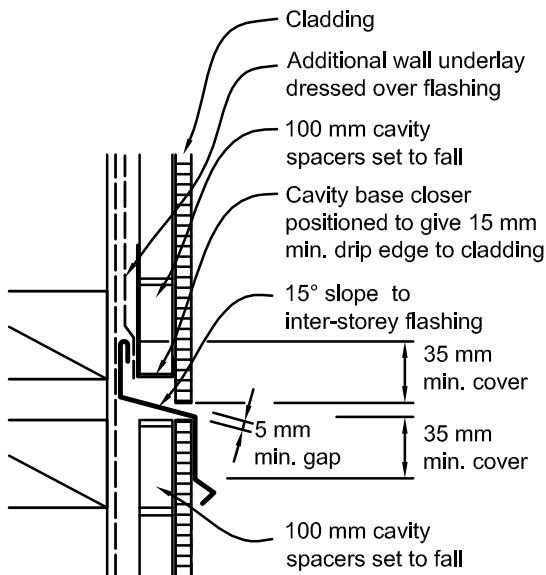

Note: (1) This detail is to be used to limit continuous cavities to the less of 2 storeys or 7 metres.

9.1.9 Windows and doors

9.1.9.1 Within this acceptable solution, aluminium window and door joinery shall:

- a) be aluminium framed; and
- b) have heads that are horizontal only; and
- c) for any one frame, be of a size that does not exceed:
 - i) for sills above floor level, maximum frame dimensions of 5000 mm wide x 5000 mm high, and a maximum frame area of 13.5 m², or
 - ii) for sills at floor level, maximum width of 6000 mm and maximum overall frame area of 16.0 m².

COMMENT: Sloped heads require specifically designed kick-out flashings at bottom edges of head *flashings*.

Where width outlined in Paragraph 9.1.9.1 are beyond the limits for sill and head trimmer *framing* in NZS 3604, specific engineering design of the *framing* is required.

Certain aluminium joinery sections and installation requirements may not be able to meet the details of this acceptable solution, especially in regard to window facing cover, sill support, window fixing, and sill flashing requirements. The window details in these cases require *specific design*.

9.1.9.2 Windows and doors shall comply with Subsection 4.4.1 of the Building Product Specifications. Reveals shall comply with NZS 3602. Window details specific to particular *claddings* are given in Sections [9.2](#), [9.3](#), [9.4](#), [9.5](#), [9.6](#), [9.7](#), [9.8](#), and [9.9](#). Door details shall be based on window details and shown in [Figure 7.4.1.1](#), [Figure 7.4.2.1](#), [Figure 9.1.10.3](#), and [Figure 9.1.10.4](#).

9.1.9.3 After installation, the flange forming the window or door facing shall have an overlap to the surrounding *cladding* material or associated back *flashings* of:

- a) for jambs, 10 mm minimum; and

Wall claddings

b) for sills, 8 mm minimum.

9.1.9.4 Treatment of the window openings for *direct fixed wall claddings* shall be as shown in [Figure 9.1.9.4](#). Jamb battens for window openings in *direct fixed wall claddings* shall:

- a) be nominal 20 mm (between limits of 18 mm and 25 mm in thickness); and
- b) a minimum 45 mm wide; and
- c) of timber complying with B2/AS1.

COMMENT: The solvents from freshly LOSP-treated timber may melt polystyrene, so these should not be used together.

Solid horizontal cavity spacers risk obstruction of air flow in cavities and risk bridging moisture across the cavity.

Battens will be fixed by the *cladding* fixings, which will penetrate the *wall framing*. Battens will therefore need only temporary fixing until the *cladding* is fixed. Polystyrene battens may be temporarily adhered to the *wall underlay*.

9.1.9.5 For *direct fixed claddings*, windows and doors shall have a 5 mm stand-off of the flange to the *cladding* to allow for air intrusion to the trim cavity for pressure equalisation. Note that this gap is sealed or trimmed down the jambs, but left open along the sill.

9.1.9.6 Window openings for *wall claddings over drained cavities* shall be as shown in [Figure 9.1.9.6](#). There shall be no sill *flashing*.

9.1.9.7 For cavity fixed *claddings*, windows and doors shall finish against the *cladding*, except for flat fibre cement and ply *claddings* that require a 5 mm stand-off to allow for sealant weather seals between facings and *cladding* (see [Figure 9.7.7.1B](#)).

9.1.9.8 *Flashings* shall comply with [Part 4. Flashings](#). Materials for *flashings* shall be selected from [Table 4.5.1.1](#), [Table C.1.1.1A](#), [Table C.1.1.1B](#), and [Table C.1.1.1C](#).

9.1.9.9 Compressible foam tape shown behind window facings and *cladding* joints shall be closed cell PVC foam, with:

- a) hardness 55-60 to ASTM D2240 Scale OO; and
- b) grade VE-43 to ASTM D1667; and
- c) compression set of 20% maximum to ASTM D1667; and
- d) UV weathering in UV Weatherometer for 1500 light hours to ASTM G154 or ASTM G155 with no visible deterioration in appearance.

9.1.9.10 Fixings for windows and doors,

- a) install windows and doors using pairs of minimum 75 x 3.15 galvanised jolt head nails or 8 gauge x 65 mm stainless steel screws, through reveals into surrounding framing at:
 - i) maximum 450 mm centres along sills, jambs, and heads, and
 - ii) maximum 150 mm from reveal ends; and
- b) install packers between reveals and framing at all fixing points, except between head reveals and lintels.

Wall claddings

Figure 9.1.9.4: General window and door opening for direct fixed

Paragraph 9.1.9.4, Figure 9.1.9.4, Figure 9.4.6.1A, Figure 9.4.6.1B, Figure 9.4.6.1C, Figure 9.4.6.1D, Figure 9.5.4.2, Figure 9.6.6.8, Figure 9.7.7.1A, and Table 4.5.1.1

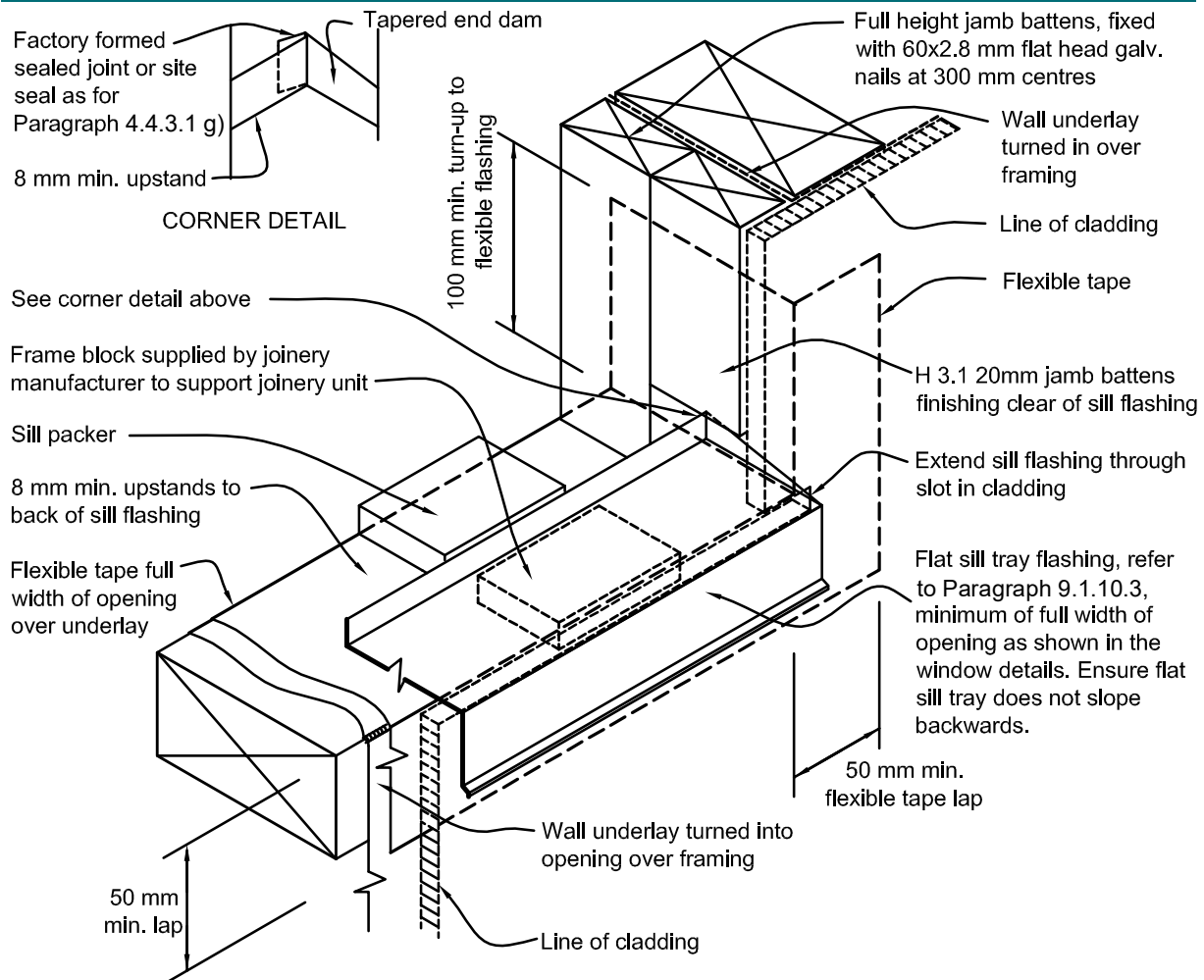

Notes:

- (1) Detailed *cladding* not shown for clarity. Refer to specific *claddings*.
- (2) Sill *flashing* shall extend back past the condensation channel of the window.
- (3) Head to be treated similarly with continuous *wall underlay* and *flexible flashing tape* at corners.
- (4) Refer to individual *cladding* details for jamb *flashings* and sill tray return requirements.

Wall claddings

Figure 9.1.9.6: General window and door opening with drainage cavity

Paragraphs [9.1.4.1](#), [9.1.9.6](#), [Figure 9.2.10.3](#), [Figure 9.3.9.1](#), [Figure 9.4.7.1](#), [Figure 9.4.7.2](#), [Figure 9.5.4.3](#), [Figure 9.6.6.8](#), [Figure 9.6.7.9A](#), [Figure 9.7.7.1B](#), [Figure 9.9.8.1B](#), and [Table 4.5.1.1](#)

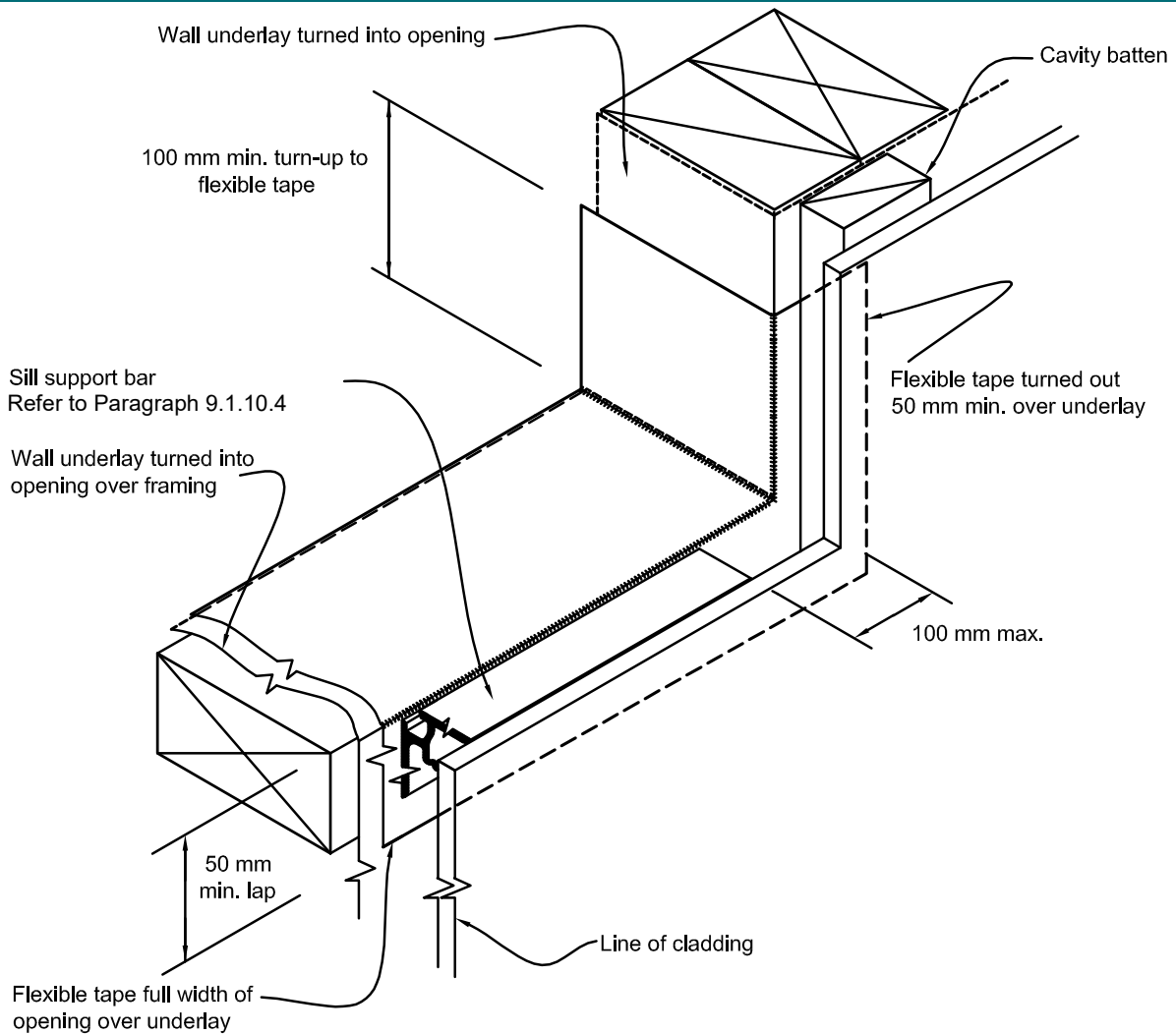

Notes:

- (1) Detailed *cladding* not shown for clarity. Refer to specific *claddings*.
- (2) Head to be treated similarly with continuous *wall underlay* and *flexible flashing tape* at corners.
- (3) Refer to individual *cladding* details for jamb *flashings*.

Wall claddings

9.1.10 Window and door heads, sills, and jambs

9.1.10.1 Windows and doors shall include head flashings, finished to the wall underlay as shown in [Figure 9.1.10.1](#), by either using flexible flashing tape, or lapping an additional layer of wall underlay over the upstand. The additional wall underlay shall extend to the top of the wall, or to the nearest lap above, and be lapped under the top layer.

Figure 9.1.10.1: General sealing of head flashing

Paragraphs [4.5.5.1](#), [9.1.10.1](#), [9.1.10.2](#), [Figure 9.3.9.1](#), [Figure 9.4.6.1A](#), [Figure 9.4.6.1B](#), [Figure 9.4.6.1C](#), [Figure 9.4.6.1D](#), [Figure 9.4.7.1](#), [Figure 9.4.7.2](#), [Figure 9.6.6.8](#), [Figure 9.6.7.9A](#), [Figure 9.7.7.1B](#), [Figure 9.9.8.1B](#), and [Figure 9.5.4.2](#)

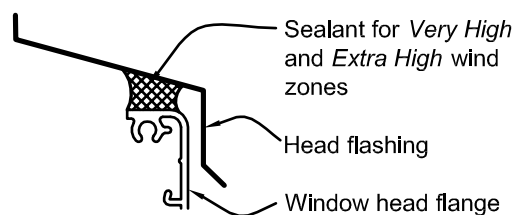
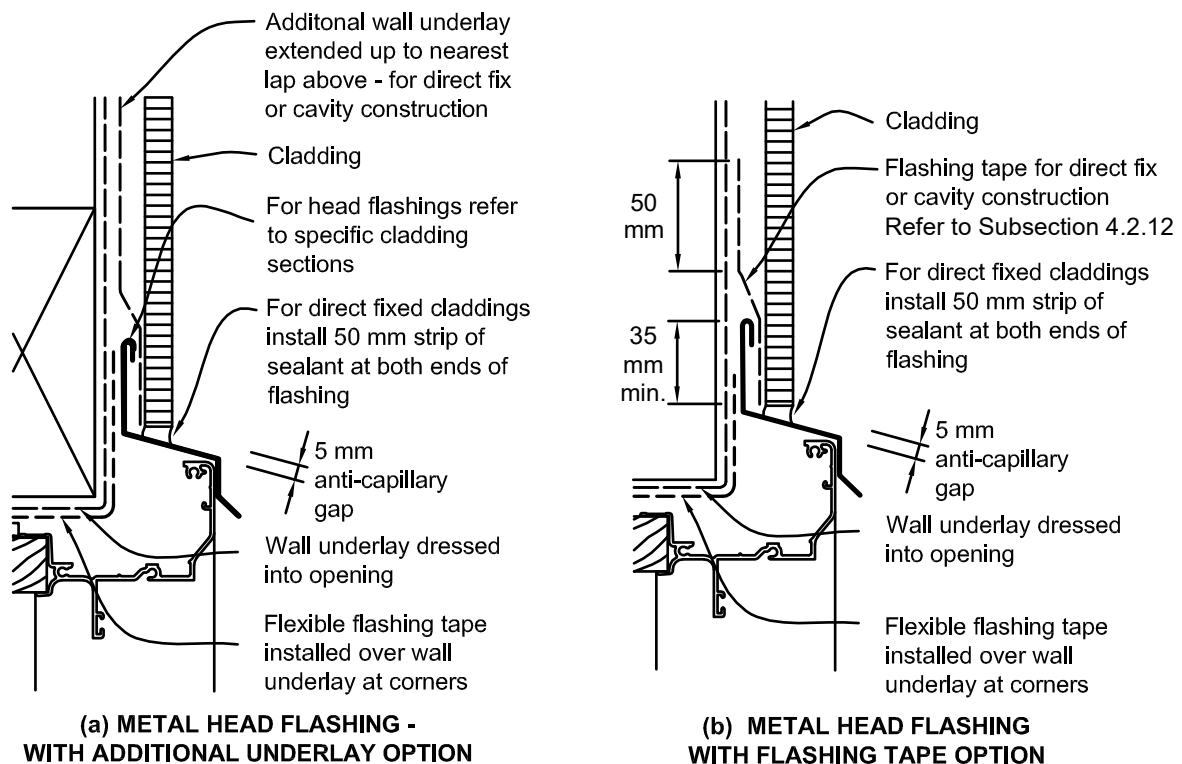

(c) METAL HEAD FLASHING SEALANT FOR VERY HIGH AND EXTRA HIGH WIND ZONES

Note: (1) May also use wall underlay lapped over flashing upstand in lieu of flexible flashing tape. Refer to cladding window details such as [Figure 9.7.7.1A](#).

9.1.10.2 Head flashings shall be in accordance with Paragraph [4.5.5.1](#) and [Table 4.5.1.1](#), unless specifically shown otherwise, and shall:

- direct water to the outside of the wall cladding; and
- finish to the window head with clearance dimensions shown in [Figure 9.1.10.1](#); and

Wall claddings

- c) for *direct fixed claddings*, have 50 mm bead of sealant installed between *cladding* and each end of the head *flashing*; and
- d) for *wall claddings* on cavity walls:
 - i) incorporate 10 mm turn-ups as *stopends*, terminating at the inside face of the *cladding* so they do not pass through the *cladding*, and
 - ii) permit ventilation of the *drained cavities* above, by the installation of cavity base closers as shown in [Figure 9.1.7.4A](#); and
- e) for Very High and Extra High *wind zones*, have sealant installed between underside of head *flashing* and top edge of window head flange (see [Figure 9.1.10.1\(c\)](#)).

COMMENT: *Stopends* are useful to prevent water moving past the ends of head *flashings*. However, additional problems of weatherproofing occur where the *stopend* penetrates the *cladding*.

9.1.10.3 *Direct fixed claddings* shall have:

- a) window sills with sill tray *flashings* as shown in Sections [9.2](#), [9.3](#), [9.4](#), [9.5](#), [9.6](#), [9.7](#), [9.8](#), and [9.9](#) for each *cladding* type. The sill *flashing* shall extend back past the condensation channel of the window. Ensure flat sill trays do not slope backwards. The 5 mm gap between the window facing and sill tray must not be sealed; and
- b) doors sills installed as for windows, with sill trays and as shown in [Figure 9.1.10.3](#).

9.1.10.4 *Claddings over a drained cavity* shall have:

- a) window sills as shown in Sections [9.2](#), [9.3](#), [9.4](#), [9.5](#), [9.6](#), [9.7](#), [9.8](#), and [9.9](#), without sill *flashings*; and
- b) door sills as shown in [Figure 9.1.10.4](#); and
- c) *sill support bars* and mechanisms for all doors, and for windows with a trim opening wider than 600 mm. *Sill support bars* and mechanisms shall comply with BRANZ Evaluation Method EM6, E2/VM1, and B2/AS1. *Sill support bars* and mechanisms must be installed prior to installation of the window or door.

COMMENT: *Sill support bars* and mechanisms are rated for their capacity to support the total weight of a joinery unit when installed at given offsets from the frame depending on *cladding* type. Designers select an appropriate complying support mechanism for the joinery weight. Manufacturers provide build-in instructions for support bars and mechanisms.

9.1.10.5 Mitred aluminium window and door sills, for both *cavity* and *direct fixed*, shall have a corner soaker fitted to the back of the sill/jamb joint and installed at point of manufacture. The soaker will be designed to act as a secondary device to prevent water ingress to the *building* in support of the primary mitre seals. Soaker materials shall be either uPVC, aluminium, polypropylene, high impact styrene or other semi rigid moulded polymeric material.

9.1.10.6 *Sill support bars* and mechanisms must be designed to not impede the possible drainage of water from surfaces of sill *flashing* tape, and permit an air passage (of at least 1000 mm²/m sill width) from the *drained cavity* to the window/door trim cavity.

9.1.10.7 Jamb *flashings* shall be installed as shown in Sections [9.2](#), [9.3](#), [9.4](#), [9.5](#), [9.6](#), [9.7](#), [9.8](#), and [9.9](#).

9.1.10.8 Jamb *flashings*, where required, shall overlap sill *flashings*, and direct moisture to the outside face of the *cladding system*.

Wall claddings

Figure 9.1.10.3: Door sills for direct fix

Paragraphs 9.1.9.2, 9.1.10.3, 9.4.6.2, 9.5.4.2, and Figure 8.5.6.1D

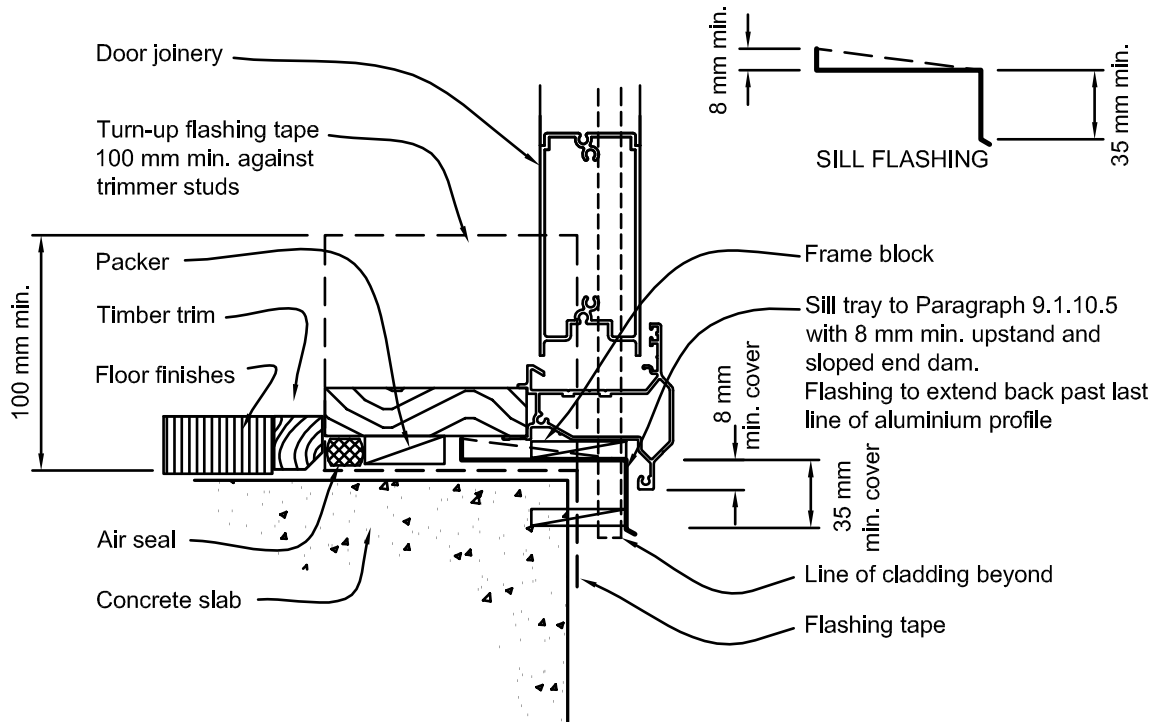

(a) CONCRETE SLAB

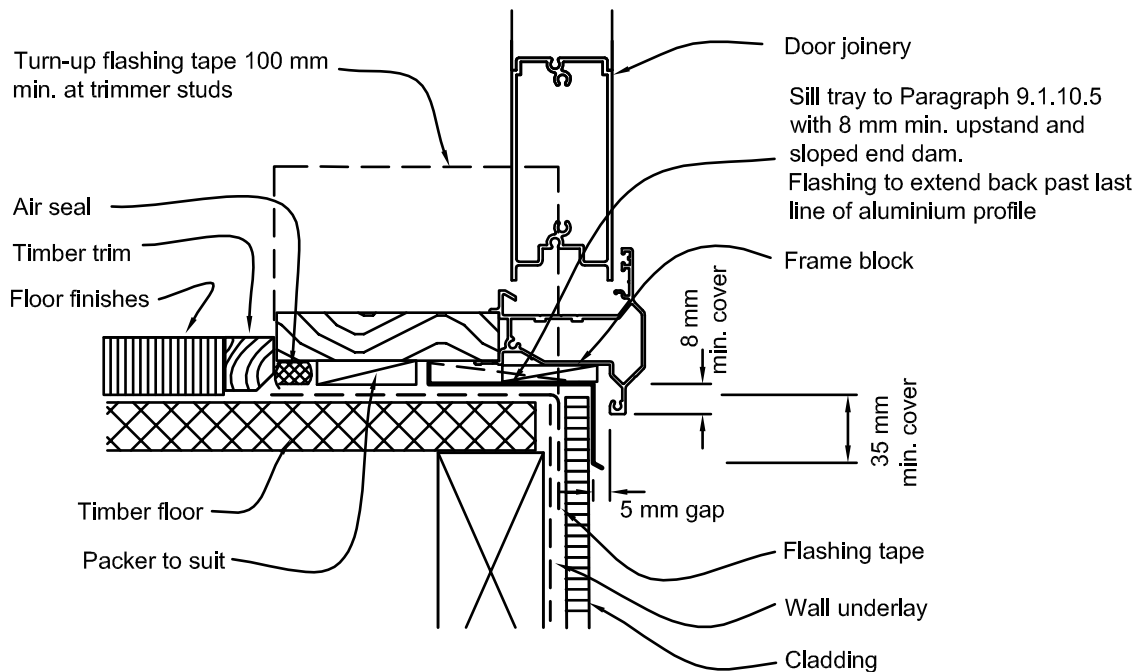

(b) TIMBER FLOOR

Wall claddings

Figure 9.1.10.4: Door sills for cavity construction

Paragraphs [9.1.9.2](#), [9.1.10.4](#), [9.4.7.3](#), [9.5.4.3](#), and [9.9.8.1](#)

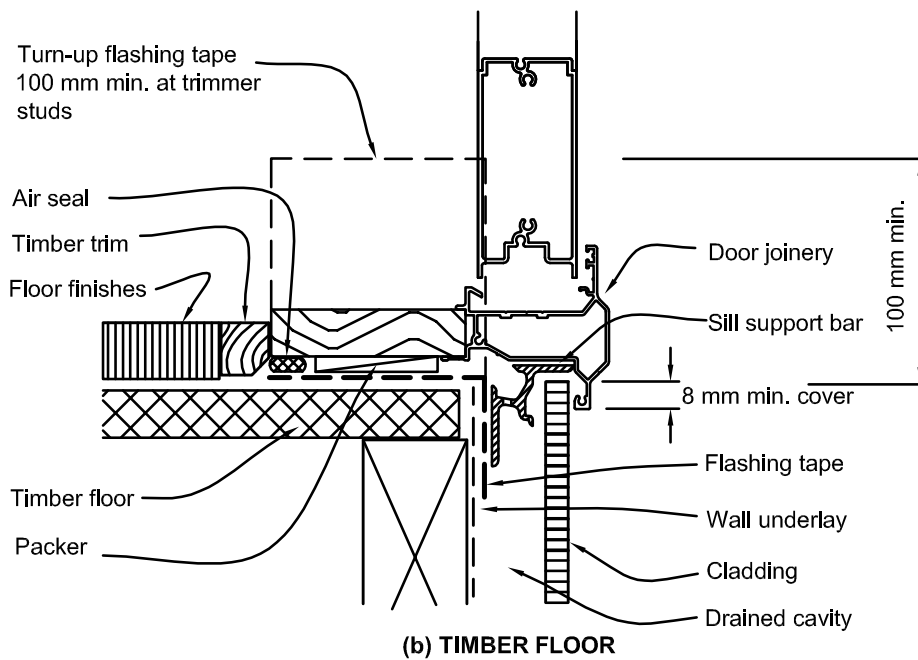
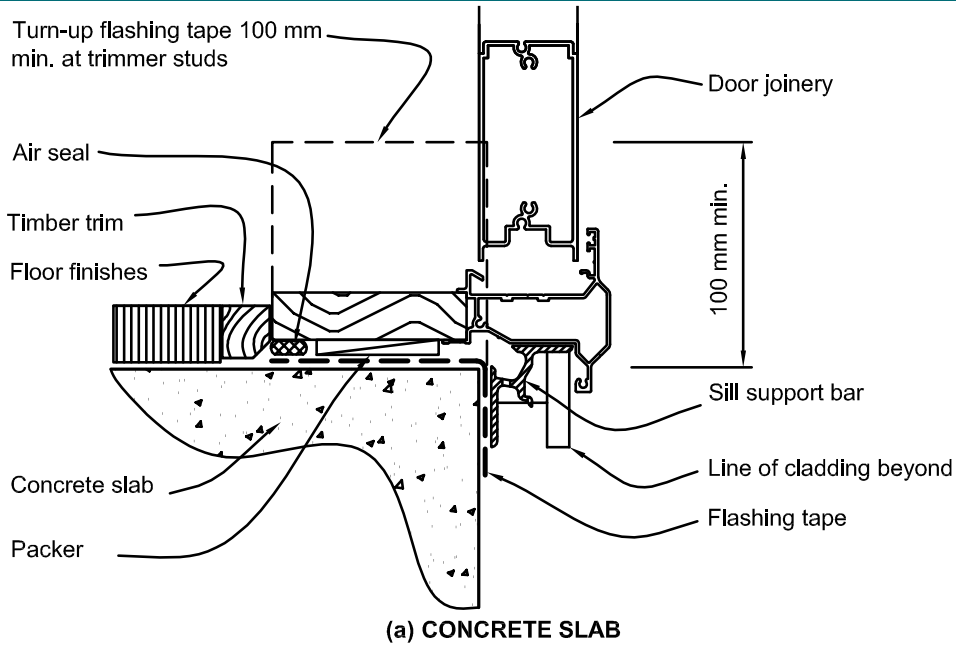

Wall claddings

9.2 Masonry veneer

9.2.1 Use and limitations

- 9.2.1.1 This section contains provisions for masonry veneer cladding. Masonry veneer shall be either:
- clay brick; or
 - concrete brick or block.

COMMENT: Natural stone bricks or blocks may be suitable. However, they are not part of this acceptable solution. Refer to the manufacturer's recommendations for *specific design* information.

- 9.2.1.2 Masonry veneer *cladding* shall be attached to timber *wall framing* as outlined in NZS 3604.

9.2.2 Materials

- 9.2.2.1 The materials and workmanship of *masonry veneer* shall be in accordance with SNZ HB 4236 and have a maximum mass of veneer of 220 kg/m² and minimum veneer thickness of 70 mm.
- 9.2.2.2 Masonry units shall be laid-up in running bond.
- 9.2.2.3 Mortar, materials (cement, sand and admixtures) shall comply with NZS 4210.
- 9.2.2.4 Mortar joints less than 24 hours old shall not be subject to vibration, such as would result from the nailing of interior linings.

9.2.3 Installation

- 9.2.3.1 *Masonry veneer construction* shall be as shown in [Figure 9.2.3.1](#), and have:
- a maximum height of veneer above adjacent *finished ground level* of 7 m; and
 - a maximum height of veneer of 4.0 m, measured from the top of the concrete masonry *wall*, foundation *wall* or slab edge foundation. In the case of a veneer faced concrete block *wall* or foundation *wall* height is measured from the top of that *wall*; and
 - a maximum height of veneer of 5.5 m on a gable end *wall*; and
 - a minimum *wall* or panel width of 230 mm.

Wall claddings

Figure 9.2.3.1: Masonry veneer height limitations

Paragraph [9.2.3.1](#)

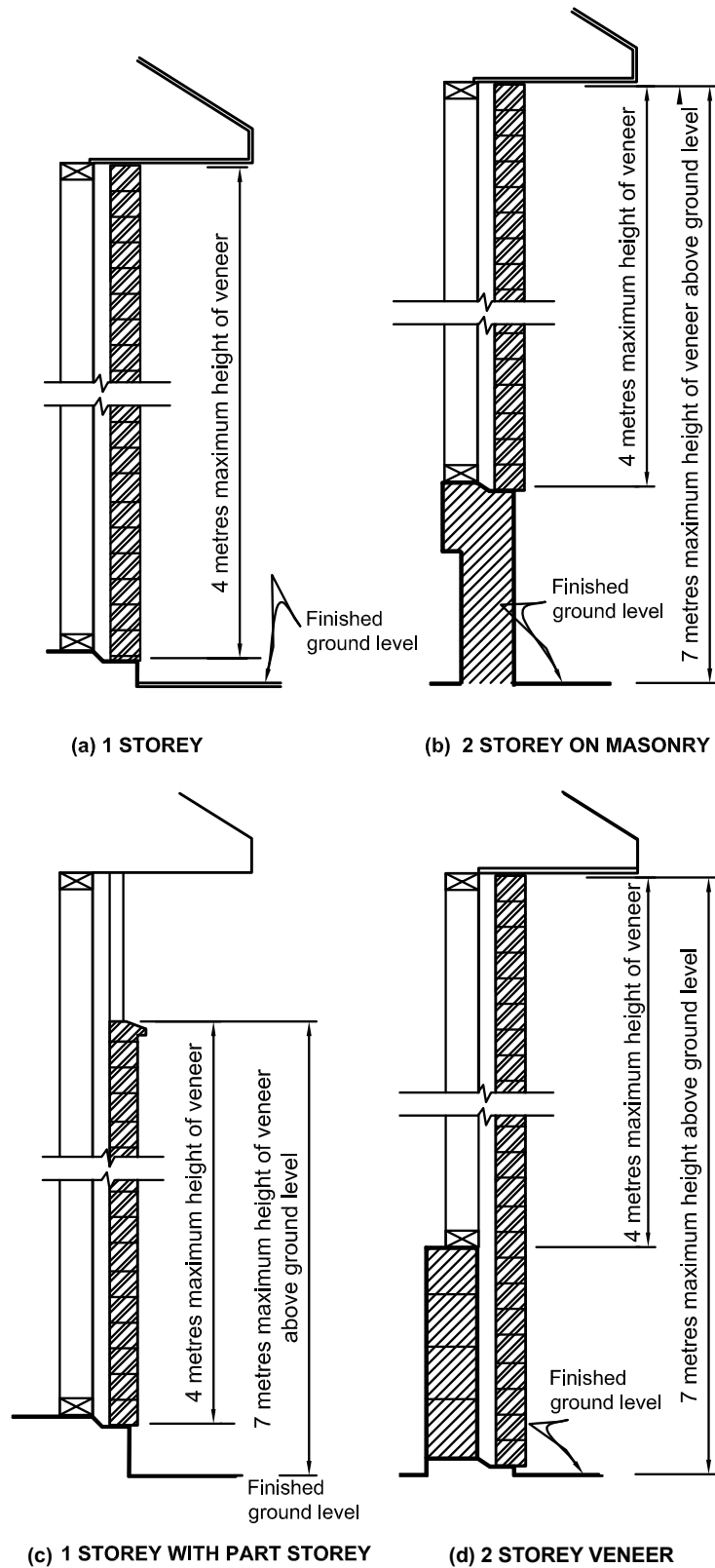

Wall claddings

9.2.4 Flashings

- 9.2.4.1 Sill and head flashings shall be as described in Section [4.2](#) and be either:
- 1.5 mm butyl rubber (refer to Subsection [4.2.10](#)); and
 - 2 ply asphaltic pliable waterproofing *membrane* (refer to Subsection [4.2.11](#)); and
 - pliable polyethylene minimum 0.5 mm thick complying with *DPC/DPM* in [Table C.2.1.1](#).
- 9.2.4.2 Jamb flashings shall be:
- 2 ply asphaltic pliable waterproofing *membrane* complying with AS/NZS 2904; and
 - pliable polyethylene minimum 0.5 mm thick complying with *DPC/DPM* [Table C.2.1.1](#).

COMMENT: For further information refer to ASTM C1330 for backing rod material performance.

9.2.5 Foundation support and damp proofing

- 9.2.5.1 *Masonry veneer* shall be supported by one, or a combination of, the following:
- concrete or masonry foundation *wall*; and/or
 - thickened slab edge footing; and/or
 - concrete or masonry lower storey *wall*.
- 9.2.5.2 The level of the concrete slab above ground shall comply with [Figure 9.1.2.1](#).
- 9.2.5.3 The top of a foundation wall or concrete slab shall be stepped down, so that the surface supporting the veneer is 50 mm or more below the surface supporting the timber *framing*.
- 9.2.5.4 Provide a *damp-proof course* to the stepped rebates supporting *masonry veneer*. This includes stepped rebates in foundations, or on top of concrete or concrete masonry *walls* supporting veneers. *Damp-proofing material* shall be as outlined in [Table C.2.1.1](#) and be as follows:
- for rebates lower than ground floor level:
 - two coats of bituminous liquid, or
 - 1.0 mm butyl rubber or bituminous sheet, or
 - 0.25 mm polythene or polyethylene *damp-proof membrane*; and
 - for rebates above ground floor level:
 - 1.0 mm butyl rubber or bituminous sheet, or
 - 0.25 mm polythene or polyethylene *damp-proof membrane*.
- 9.2.5.5 For sheet and *membrane damp-proofing materials* used to satisfy Paragraph [9.2.5.4](#), joints shall be lapped a minimum of 150 mm.
- 9.2.5.6 Rebates shall have dimensions to accommodate the required cavity width in Subsection [9.2.6](#) and the thickness of the veneer so that the veneer is supported within the tolerances outlined in [Figure 9.2.5.6A\(i\)](#) and [Figure 9.2.5.6B\(k\)](#).

Wall claddings

Figure 9.2.5.6B: Masonry veneer details

Paragraphs [9.2.5.6](#) and [9.2.6.5](#)

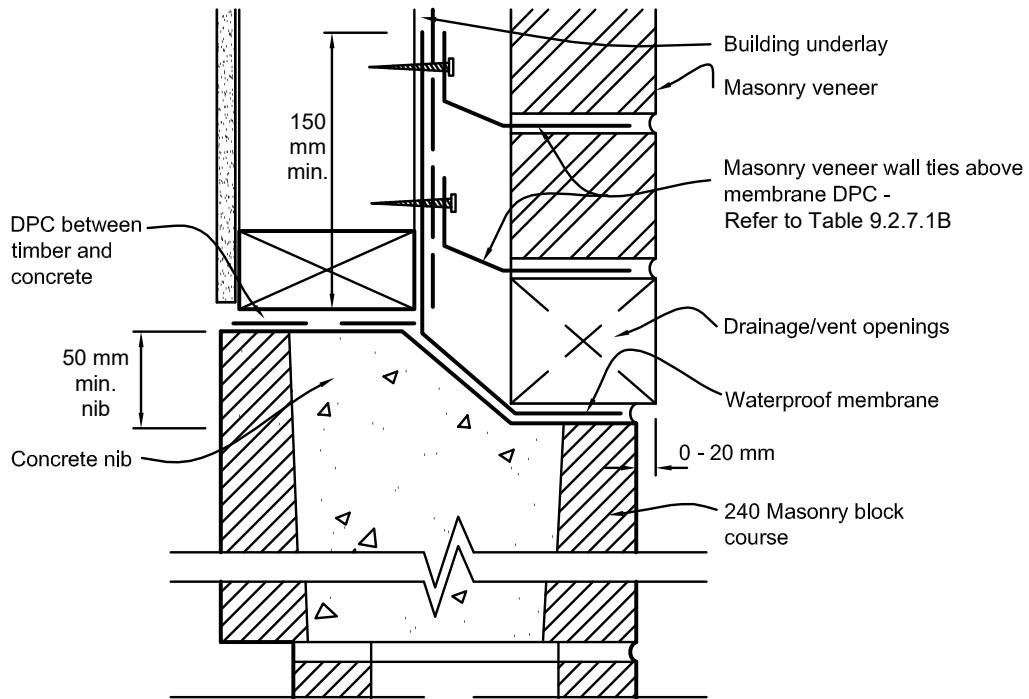

(k) MASONRY VENEER - ABOVE GROUND SUPPORT

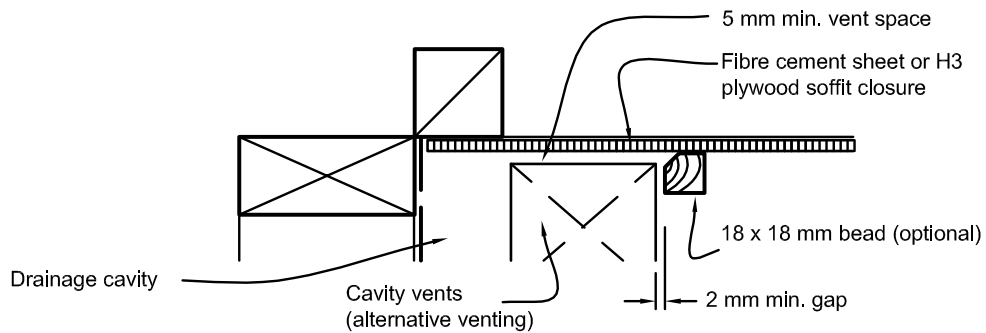

(l) MASONRY VENEER - SOFFIT DETAIL

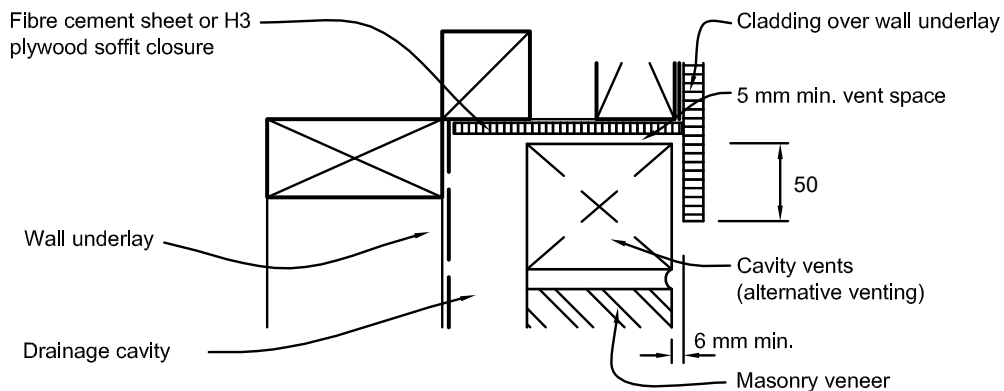

(m) MASONRY VENEER - CANTILEVER UPPER FLOOR

Wall claddings

9.2.6 Cavities

- 9.2.6.1 Paragraphs [9.1.7.4\(a\)](#), [9.1.7.4\(b\)](#), [9.1.7.4\(d\)](#), [9.1.1.5](#), [9.1.7.10](#), and [9.1.8.3](#) shall apply to *masonry veneer* cavities.
- 9.2.6.2 The clear width of cavity between the *masonry veneer* and the exterior face of the *wall underlay* shall not be less than 40 mm or more than 75 mm wide measured at any part of the cavity.

COMMENT: It is important to maintain the minimum cavity width of 40 mm after allowing for construction tolerances and thicknesses of *wall underlays* and sheet bracing.

- 9.2.6.3 Pipes and services shall not be placed in the cavity other than passing directly through the cavity to the exterior.
- 9.2.6.4 The cavity shall be drained and vented to outside at the bottom of wall panels, and above openings by open perpend that:
- are a minimum of 75 mm in height, by the width of the vertical mortar joint; and
 - at centres not exceeding 800 mm (where drainage/weep holes are less than 75 mm high, decrease spacing to give a ventilation area of 1000 mm²/m wall length); and
 - are fitted with vermin proofing where gaps greater than 13 mm exist.
- 9.2.6.5 The cavity shall be ventilated to the outside at the top of *walls* by either similar vents as at the bottom, or a continuous 5 mm minimum gap between the top course and soffit board, with a cover bead to outside that maintains a minimum 2 mm gap to masonry (refer to [Figure 9.2.5.6B\(l\)](#)).
- 9.2.6.6 The cavity shall be vented under openings exceeding 2.4 metres wide through gaps in perpend positioned at 1/3 points along the opening except at opening ends. Where these vent openings are used, protect from water entry using cantilevered sill bricks, as shown in [Figure 9.2.10.3\(f\)](#).
- 9.2.6.7 The cavity shall be sealed off from the subfloor and *roof* space.

9.2.7 Wall ties

- 9.2.7.1 *Masonry veneer* shall be attached to *wall framing* by wall ties. Wall ties and their spacings and embedment shall be in accordance with the requirements of NZS 4210 and [Table 9.2.7.1A](#), [Table 9.2.7.1B](#), and [Table 9.2.7.1C](#).

COMMENT: Variations in cavity width will require compensating adjustments to the length of masonry tie used.

- 9.2.7.2 Screw fixings shall be minimum 12 gauge, 35 mm long hex washer face, galvanised or stainless steel to suit the ties required under [Table 9.2.7.1C](#).
- 9.2.7.3 Corrosion protection for wall ties and screws shall be determined by the exposure zone outlined in NZS 3604 and as outlined in [Table 9.2.7.1C](#).

Wall claddings

Table 9.2.7.1A: Specification of maximum tie spacings for type B veneer ties

Paragraph 9.2.7.1, Figure 9.2.5.6A, and Figure 9.2.5.6B

Cladding type	Seismic zone ⁽¹⁾	Tie type ^{(2),(3)}	Maximum horizontal spacing (mm) ⁽⁴⁾	Maximum vertical spacing (mm) ⁽⁴⁾
Masonry veneer < 180 kg/m ²	1	EL	600	400
	2 ⁽⁵⁾	EM	600	400
	3	EH ⁽⁶⁾	600	400
	4	SED ⁽⁷⁾	SED ⁽⁷⁾	SED ⁽⁷⁾
Masonry veneer 180 to 220 kg/m ²	1	EM	600	400
	2 ⁽⁵⁾	EH ⁽⁶⁾	600	400
	3	EH ⁽⁶⁾	600	400
Masonry veneer > 220 kg/m ²	1, 2 ⁽⁵⁾ , 3	SED ⁽⁷⁾	SED ⁽⁷⁾	SED ⁽⁷⁾

Notes:

(1) Refer to NZS 3604 for seismic zones.

(2) Type B and Prefix E indicate masonry ties manufactured to AS/NZS 2699.1.

(3) L (Light), M (Medium), H (High) indicate strength capability of ties in AS/NZS 2699.1.

(4) Maximum masonry tie spacings of 600 mm horizontally and 400 mm vertically.

(5) Use seismic zone 2 (minimum) for Christchurch region comprising Christchurch City, Waimakariri District, and Selwyn District.

(6) EM may be used if the horizontal spacings do not exceed 400 mm and the vertical spacings do not exceed 300 mm.

(7) Spacing of ties to be determined by specific engineering design.

Table 9.2.7.1B: Placement of wall ties

Paragraph 9.2.7.1, Figure 9.2.5.6A, and Figure 9.2.5.6B

Location	Placement of masonry ties ⁽¹⁾
Unsupported panel sides and edges of openings	Within 300 mm of panel side or edge.
Top of veneer panels and top of panels under openings	Within 300 mm or two courses (whichever is the smaller) of top of veneer
Bottom of veneer panel in masonry rebate sealed with liquid applied <i>damp-proof course</i> Bottom of veneer panel supported on steel angle lintel	Within 300 mm or two courses (whichever is the smaller) from bottom of veneer
Bottom of veneer panel in masonry rebate with <i>membrane damp-proof course</i>	In each of the first two courses

Note: (1) Ties are to be screw fixed (that is, non-impact method) using screws outlined in Table D.3.2.1.

Table 9.2.7.1C: Corrosion protection to masonry wall ties

Paragraphs 9.2.7.1, 9.2.7.2, and 9.2.7.3

Exposure zone	316, 316L, or 304 stainless steel	470 g/m ² galvanising on mild steel
Zone B	Yes	Yes
Zone C	Yes	Yes
Zones D and E	Yes	–

Wall claddings

9.2.8 Control joints

- 9.2.8.1 *Control joints* in clay brick *masonry veneer* are not required, unless specified by the brick manufacturer.
- 9.2.8.2 Longitudinal shrinkage stresses in concrete *masonry veneer* shall be controlled by providing vertical *control joints* at not more than 6000 mm centres.
- 9.2.8.3 Vertical *control joints* shall be located:
- within 600 mm of T joints; and
 - within 600 mm of L shaped corners or by restricting the spacing to the next *control joint* to 3.2 m maximum; and
 - at changes in *wall* height, exceeding 600 mm; and
 - at changes in *wall* thickness.
- 9.2.8.4 *Control joints* shall be formed as shown in [Figure 9.2.8.4](#) and comprise:
- a backer rod of compressible foam; and
 - sealant in compliance with:
 - Type F, Class 20LM, or 25LM of ISO 11600, or
 - low modulus Type II Class A of Federal Specification TT-S-00230C.

COMMENT: For further information, refer to ASTM C1330 for backing rod material performance.

Figure 9.2.8.4: Vertical control joint

Paragraph [9.2.8.4](#)

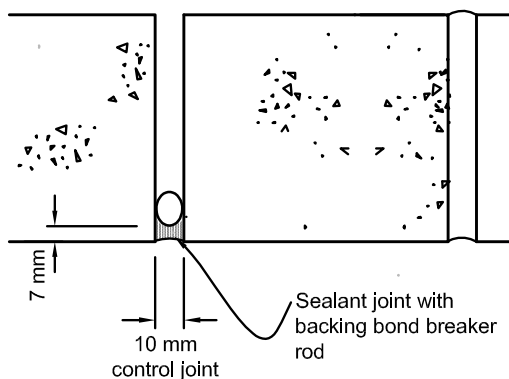

9.2.9 Openings in masonry veneer

- 9.2.9.1 Openings with *masonry veneer* above shall be spanned by steel angle lintels.
- 9.2.9.2 Openings in *masonry veneer* for meter boxes less than 500 mm wide may be installed without lintel bars or head *flashings* provided the meter box is sealed to *wall underlay* with *flashing* tape to Subsection [4.2.12](#).
- 9.2.9.3 Separate steel meter boxes from direct contact with *masonry veneer* or mortar with *flashing* tape to Subsection [4.2.12](#).
- 9.2.9.4 Lintels shall:
- be protected against corrosion as in [Table 9.2.9.4A](#) and to exposure zones outlined in NZS3604; and
 - have a minimum seating into adjacent veneer of:
 - 100 mm for spans up to, and including 2000 mm, and

Wall claddings

- ii) 200 mm for spans over 2000 mm, and
- iii) be sized in accordance with [Table 9.2.9.4B](#) and [Table 9.2.9.4C](#).

Table 9.2.9.4A: Corrosion protection to lintels

Paragraph [9.2.9.4](#)

Exposure zone	316, 316L, or 304 ⁽²⁾ stainless steel or 600 g/m ² galvanising on mild steel plus duplex coating ⁽¹⁾	600 g/m ² galvanising on mild steel ⁽¹⁾ or 300 g/m ² galvanising on mild steel plus duplex coating ⁽¹⁾
Zone B	Yes	Yes
Zone C	Yes	Yes
Zones D and E	Yes	–

Notes:

(1) To AS/NZS 2699.3.

(2) 304 stainless steel will exhibit greater levels of surface rusting than 316 stainless steel especially where not exposed to rain washing.

Table 9.2.9.4B: Minimum masonry veneer lintel sizes for masonry veneer with a maximum thickness of 70 mm

Paragraph [9.2.9.4](#)

Span of lintel (m)	Height of veneer supported:	Height of veneer supported:	Height of veneer supported:
	350 mm maximum	700 mm maximum	2000 mm maximum
up to 0.8	60 x 60 x 6 L	60 x 60 x 6 L	60 x 60 x 6 L
up to 2.0	60 x 60 x 6 L	60 x 60 x 6 L	60 x 60 x 6 L
up to 2.5	60 x 60 x 6 L	80 x 80 x 6 L	80 x 80 x 6 L
up to 3.0	80 x 80 x 6 L	80 x 80 x 6 L	125 x 75 x 6 L
up to 3.5	80 x 80 x 6 L	80 x 80 x 6 L	125 x 75 x 6 L
up to 4.0	80 x 80 x 8 L	125 x 75 x 6 L	125 x 75 x 10 L
up to 4.5	125 x 75 x 6 L	125 x 75 x 10 L	–
up to 4.8	125 x 75 x 6 L	125 x 75 x 10 L	–

Table 9.2.9.4C: Minimum masonry veneer lintel sizes for masonry veneer with a maximum thickness of 90 mm

Paragraph [9.2.9.4](#)

Span of lintel (m)	Height of veneer supported:	Height of veneer supported:	Height of veneer supported:
	350 mm maximum	700 mm maximum	2000 mm maximum
up to 0.8	60 x 80 x 6 L	60 x 80 x 6 L	80 x 80 x 6 L
up to 2.0	60 x 80 x 6 L	60 x 80 x 6 L	80 x 80 x 6 L
up to 2.5	80 x 80 x 6 L	80 x 80 x 6 L	80 x 80 x 6 L
up to 3.0	80 x 80 x 6 L	80 x 80 x 8 L	90 x 90 x 10 L
up to 3.5	80 x 80 x 8 L	90 x 90 x 10 L	125 x 75 x 10 L
up to 4.0	80 x 80 x 10 L	125 x 75 x 6 L	150 x 90 x 10 L
up to 4.5	125 x 75 x 6 L	125 x 75 x 10 L	–
up to 4.8	125 x 75 x 6 L	125 x 75 x 10 L	–

Wall claddings

9.2.10 Windows and doors

- 9.2.10.1 The openings in *wall framing* for windows and doors shall have *flexible flashing tape* applied, in accordance with Subsection [9.1.4](#).
- 9.2.10.2 Air seals shall be provided in accordance with Subsection [9.1.5](#).
- 9.2.10.3 Window *flashings* shall be installed in accordance with Subsection [9.2.4](#) and [Figure 9.2.10.3](#) and [Figure 9.2.5.6A\(h\)](#).

9.2.11 Secondary cladding

- 9.2.11.1 Where a secondary *cladding* is used with the *masonry veneer*, and is *direct fixed* to *framing* above windows or at gable ends, this shall be fully sealed on:
 - a) the face of the *cladding*; and
 - b) all edges of the *cladding*; and
 - c) a 75 mm minimum perimeter strip on the rear of the *cladding*.

Wall claddings

Figure 9.2.10.3: Masonry veneer window and door installation

Paragraphs [9.2.6.6](#) and [9.2.10.3](#)

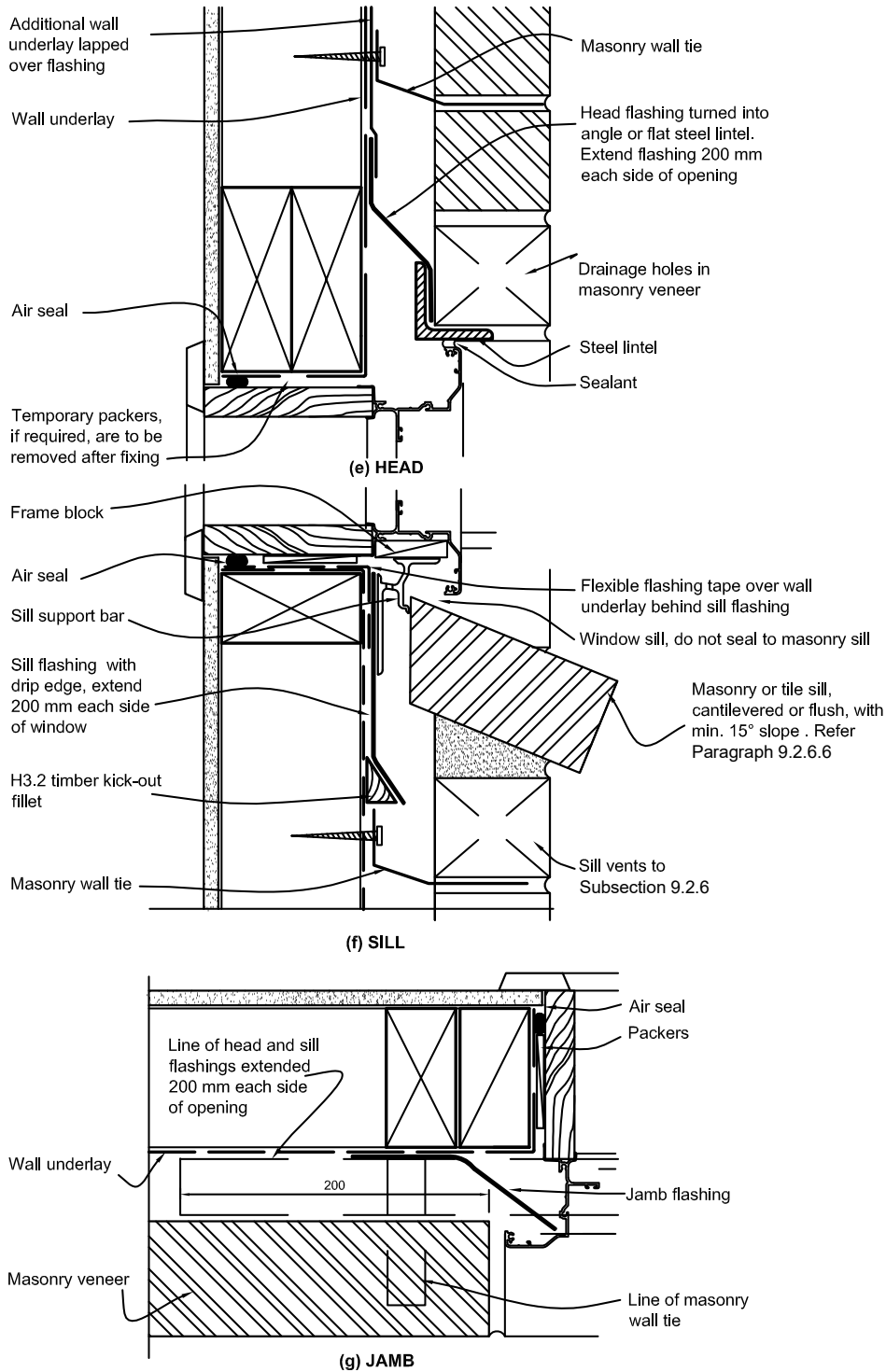

Notes: (1) Window profile to be selected to achieve the cover shown in the details.

(2) Architraves are shown for consistency only. The details may be used with rebated liner.

(3) The detail does not show window support brackets required by Paragraph [9.1.10.4](#). Refer to [Figure 9.1.9.6](#).

Wall claddings

9.3 Stucco

9.3.1 Use and limitations

9.3.1.1 This section contains provisions for *stucco cladding*. *Stucco cladding* shall be one of the following types:

- a) solid plaster *cladding* with a non-rigid backing and a *drained cavity*; or
- b) solid plaster *cladding* with a rigid backing and a *drained cavity* (refer to [Figure 9.3.1.1](#)).

Figure 9.3.1.1: Types of stucco cladding

Paragraphs [9.3.1.1](#) and [9.3.1.4](#)

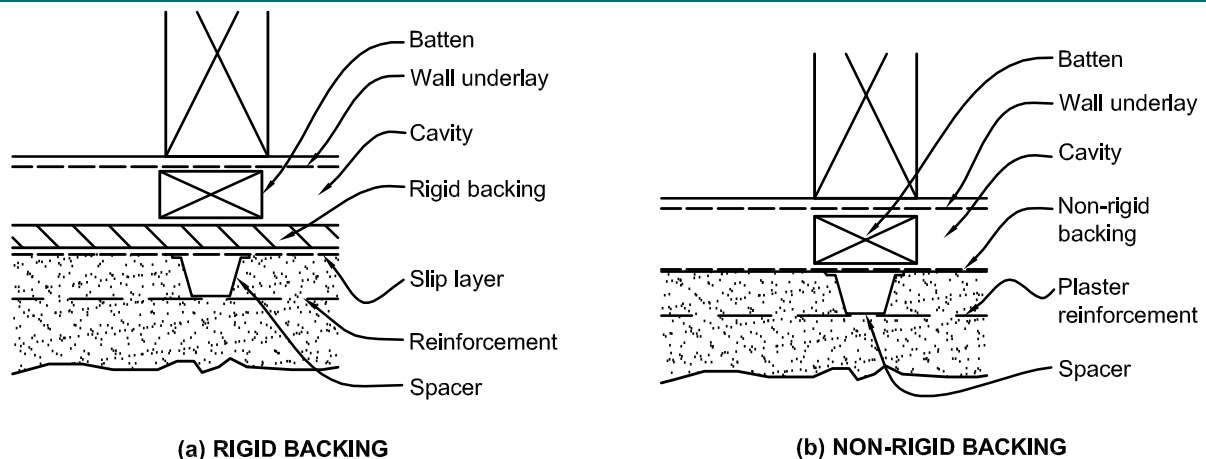

9.3.1.2 The timber *framing* of external walls supporting *stucco wall claddings* shall comply with NZS 3604 and NZS 4251.1. The *cladding system* shall be attached to the *wall framing*.

9.3.1.3 The *framing* for buildings using *stucco exterior cladding systems* shall be supported on a:

- a) concrete slab-on-ground; or
- b) continuous reinforced concrete foundation wall; or
- c) reinforced concrete masonry foundation wall.

9.3.1.4 All *stucco claddings* shall be used over a *drained cavity* as described in Subsection [9.1.7](#), and shown in [Figure 9.3.1.1](#).

9.3.1.5 All *stucco cladding* shall have *wall underlay* as specified in [Table C.2.1.1](#) to meet the following provisions:

- a) to provide a rigid or flexible *wall underlay*, fixed to the *framing* as specified in Subsections [9.1.4](#), [9.1.5](#), and [9.1.6](#); and
- b) as part of the plaster backing systems, being a flexible *wall underlay* product forming:
 - i) a non-rigid backing as specified in Subsection [9.3.4](#); or
 - ii) a slip layer provided as an overlay to a rigid backing, to permits the independent movement of plaster and backing.

9.3.1.6 *Stucco cladding systems* shall have plaster backing installed as in Subsections [9.3.4](#) and [9.3.5](#).

9.3.1.7 *Stucco cladding systems* shall have metal lath reinforcements for *stucco plaster* attached through the plaster backing as described in [Table C.3.1.1](#).

9.3.2 Materials

9.3.2.1 The materials, proportions, mixes, thickness, reinforcement materials and fixing, *control joints*, and application and curing of plaster shall comply with NZS 4251.1.

Wall claddings

9.3.3 Installation

- 9.3.3.1 Activities that will cause impact or vibration during plaster application shall not be undertaken until all plastering is completed and fully cured.
- 9.3.3.2 Movement control joints shall be as required in NZS 4251.1.

9.3.4 Non-rigid plaster backings

- 9.3.4.1 The layer of *wall underlay* forming the non-rigid backing shall be in accordance with [Table C.2.1.1](#), and as described in Paragraph [9.1.6.1](#).

9.3.5 Rigid plaster backings

- 9.3.5.1 Rigid backings shall be:
- a) made of either
 - i) plywood, or
 - ii) fibre cement sheet; and
 - b) have slip layers to Paragraph [9.3.1.5\(b\)](#).
- 9.3.5.2 Backing sheets shall be no more than 3 mm out of plane at the time of plastering.
- 9.3.5.3 Plywood backing used in *stucco cladding systems* shall be:
- a) selected from Table 6 of NZS 4251.1; and
 - b) H3 treated as per AS/NZS 2269; and
 - c) fixed as specified in Clause 4.2.4.4.2 of NZS 4251.1, except that nails shall:
 - i) be 2.8 mm in diameter, and
 - ii) penetrate *framing* by 35 mm minimum.
- 9.3.5.4 Fibre cement sheet backing used in *stucco cladding systems* shall:
- a) comply with Subsection 4.2.1 of the Building Product Specifications; and
 - b) be a minimum of 4.5 mm thick; and
 - c) span no more than 600 mm centres between *cavity battens*; and
 - d) be fixed as specified in Clause 4.2.4.5.2 of NZS 4251.1, except that nails shall:
 - i) be 2.8 mm in diameter, and
 - ii) penetrate *framing* by 35 mm minimum.

COMMENT: When the backing is used as bracing, the nailing patterns are subject to *specific design*, and the use of tested and rated systems.

9.3.6 Finishes

- 9.3.6.1 All *stucco* surfaces shall be sealed by applying a minimum of a 2-coat latex exterior paint system complying with any of Parts 7, 8, 9, or 10 of AS 3730.

COMMENT: *Stucco cladding systems* cannot be assumed to be completely weatherproof. It is necessary to ensure that corrosive salts are not carried into the plaster by moisture, causing corrosion of the reinforcing and fixings.

9.3.7 Bottom of stucco

- 9.3.7.1 The bottom of stucco wall cladding shall be in accordance with Subsection [9.1.2](#), and as shown in [Figure 9.3.7.1](#).

Wall claddings

Figure 9.3.7.1: Bottom of stucco cladding

Paragraph [9.3.7.1](#)

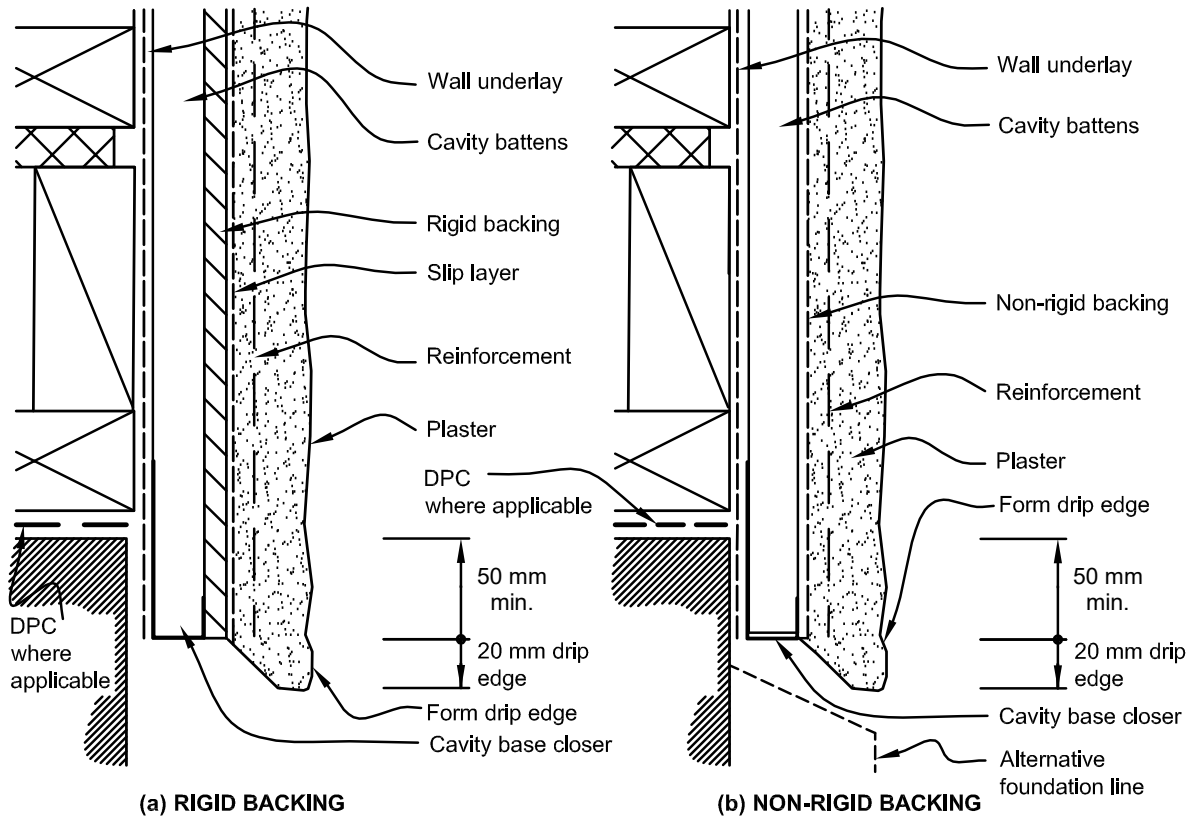

Note: (1) A 6 mm offset of *framing* to the foundation is not necessary where *drained cavities* are used.

9.3.8 Parapets and enclosed balustrades

9.3.8.1 *Parapets* shall be in accordance with [Part 6. Parapets](#).

9.3.8.2 *Enclosed balustrades* shall be in accordance with [Section 7.5](#).

9.3.8.3 *Parapets and enclosed balustrades for stucco cladding* shall be capped with metal, butyl membrane, or EPDM membrane, complying with the requirements of [Part 4. Flashings](#).

9.3.9 Windows and doors

9.3.9.1 Windows and doors shall comply with Subsection [9.1.9](#) and [9.1.10](#), as shown in [Figure 9.3.9.1](#).

Wall claddings

Figure 9.3.9.1: Windows and doors in stucco cladding
Paragraph 9.3.9.1

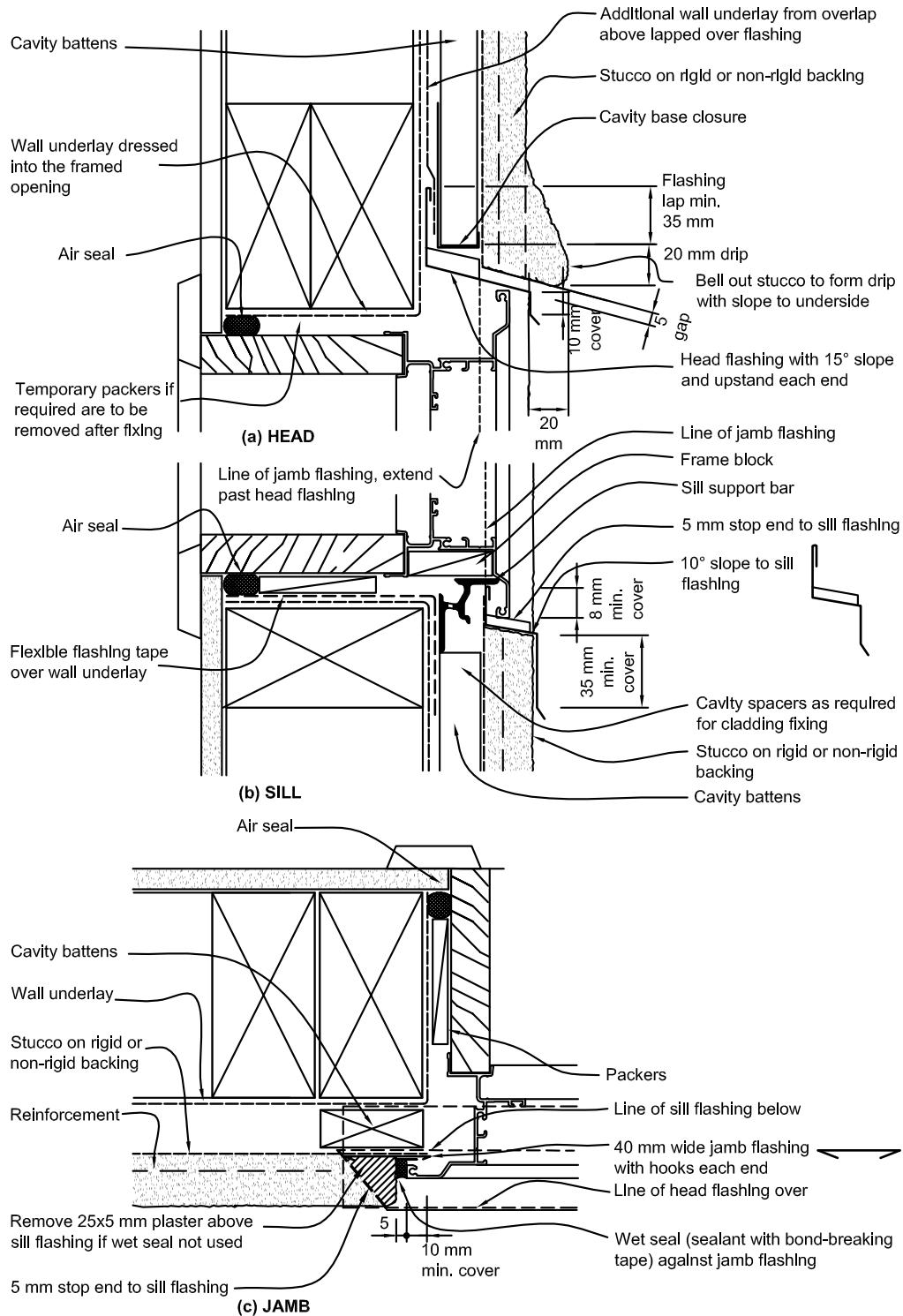

- Notes:** (1) Window profile to be selected to achieve the cover shown in the details.
 (2) Architraves are shown for consistency only. The details may be used with rebated liner.
 (3) A sill support bar conforming to EM6 and Paragraph 9.1.10.4 is required. Refer to Figure 9.1.9.6.
 (4) For sealant at head for Very High and Extra High wind zones, refer to Figure 9.1.10.1(c).

Wall claddings

9.4 Timber weatherboards

9.4.1 Use and limitations

- 9.4.1.1 This section contains provisions for timber weatherboard *cladding*. Timber weatherboards shall be one of the following types:
- horizontal bevel-back; or
 - horizontal rebated bevel-back; or
 - horizontal rusticated; or
 - vertical shiplap; or
 - vertical board and batten.
- 9.4.1.2 Profiles shall be as given in NZS 3617 or BRANZ Bulletin 411.
- 9.4.1.3 Timber weatherboard *claddings* shall be either *direct fixed to framing over a wall underlay* or fixed over a *drained cavity* as described in Subsection [9.1.7](#).
- 9.4.1.4 Based on the *risk score* for the *external wall* calculated as per Section [3.1](#), the weatherboard *cladding* may require the inclusion of a *drained cavity*.
- 9.4.1.5 Vertical weatherboards shall be *direct fixed* and shall only be used in the risk categories where shown in [Table 3.1.3.2](#).
- 9.4.1.6 Horizontal weatherboards shall be either *direct fixed* or fixed over a *drained cavity*, according to the risk categories as shown in [Table 3.1.3.2](#).

COMMENT: Vertical weatherboards are not used over cavities because of the need for horizontal battens, which if solid, would interfere with a *drained cavity*. Vertical weatherboards are therefore limited to low risk applications.

9.4.2 Materials

- 9.4.2.1 Timber weatherboard *cladding systems* shall include a *wall underlay* complying with [Table C.2.1.1](#) and Subsections [9.1.4](#), [9.1.5](#), and [9.1.6](#).
- 9.4.2.2 Timber selection and treatment of weatherboards shall be in accordance with NZS 3602.

9.4.3 Installation

- 9.4.3.1 A *wall underlay* complying with [Table C.2.1.1](#) shall be installed behind:
- all *direct fixed* timber weatherboards; and
 - cavity battens* for timber weatherboards installed over a *drained cavity*.
- 9.4.3.2 Fixings shall comply with [Table C.1.1.1A](#) and [Table C.3.1.1](#).
- 9.4.3.3 Timber weatherboards shall be drilled for nailing at all joints and ends. All cut ends of painted weatherboards shall be primed.

9.4.4 Horizontal weatherboards

- 9.4.4.1 Laps shall be:
- 32 mm for non-rebated bevel-back boards; or
 - 25 mm horizontal lap for rebated bevel-back and rusticated boards, with a minimum gap of 2 mm at the overlap between boards.
- 9.4.4.2 Joints shall be made only over supports and have:
- corrosion-resistant soakers fitted, complying with Subsections [4.2.3](#), [4.2.4](#), [4.2.5](#), [4.2.6](#), [4.2.7](#), [4.2.8](#), and [4.2.9](#); or
 - scarf or splay joints.

Wall claddings

9.4.4.3 Boards shall be fixed through the *wall underlay* to the *framing* in accordance with [Table C.3.1.1](#).

9.4.4.4 External corners shall be weatherproofed by one of the following methods:

- a) for rusticated and bevel-back weatherboards, corner boxes with:
 - i) scribes for bevel-back weatherboards, as shown in [Figure 9.4.4.4B](#), or
 - ii) Plugs or scribes for rusticated weatherboards, as shown in [Figure 9.4.4.4B](#); and
- b) For bevel-back weatherboards:
 - i) mitred joints with back flashing as shown in [Figure 9.4.4.4B](#), or
 - ii) mitred joints with corrosion-resistant soakers (refer to Subsections [4.2.3](#), [4.2.4](#), [4.2.5](#), [4.2.6](#), [4.2.7](#), and [Figure 9.4.4.4A](#)).

9.4.4.5 Internal corners shall have a corrosion-resistant *flashing* fitted behind the weatherboards and be made *weathertight* as shown in [Figure 9.4.4.5](#).

Figure 9.4.4.4A: Corner soakers for bevel-back weatherboards

Paragraphs [9.4.4.4](#), [9.4.5.6](#), and [Figure 9.5.3.6](#)

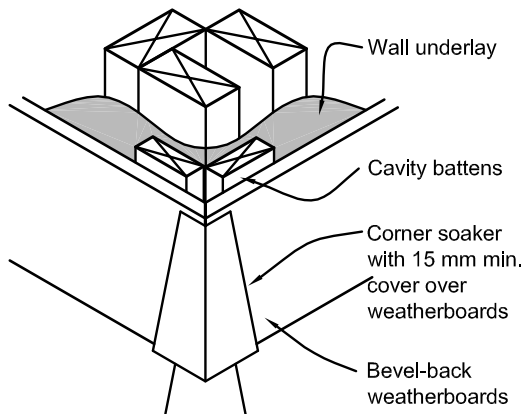

Note: (1) Soaker corner for direct fixed weatherboards is similar to [Figure 9.5.3.6](#).

Wall claddings

Figure 9.4.4.4B: External corners for horizontal weatherboards

Paragraph 9.4.4.4

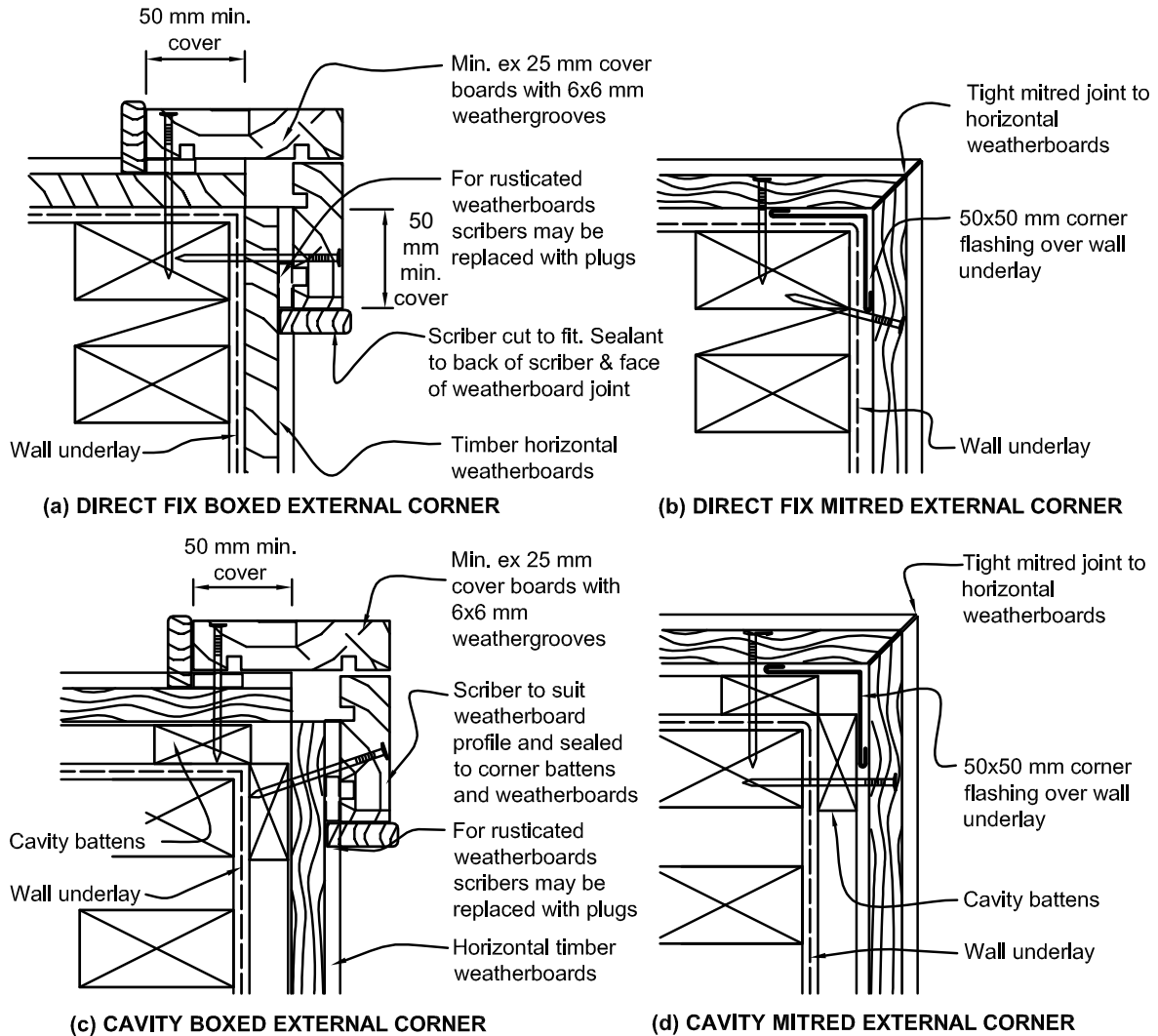

Note: (1) Corner battens shall be sized to provide 50 mm minimum cover over *cladding*.

Wall claddings

Figure 9.4.4.5: Internal corners for horizontal or vertical weatherboards

Paragraph 9.4.4.5, Figure 9.5.3.7, and Table 4.5.1.1

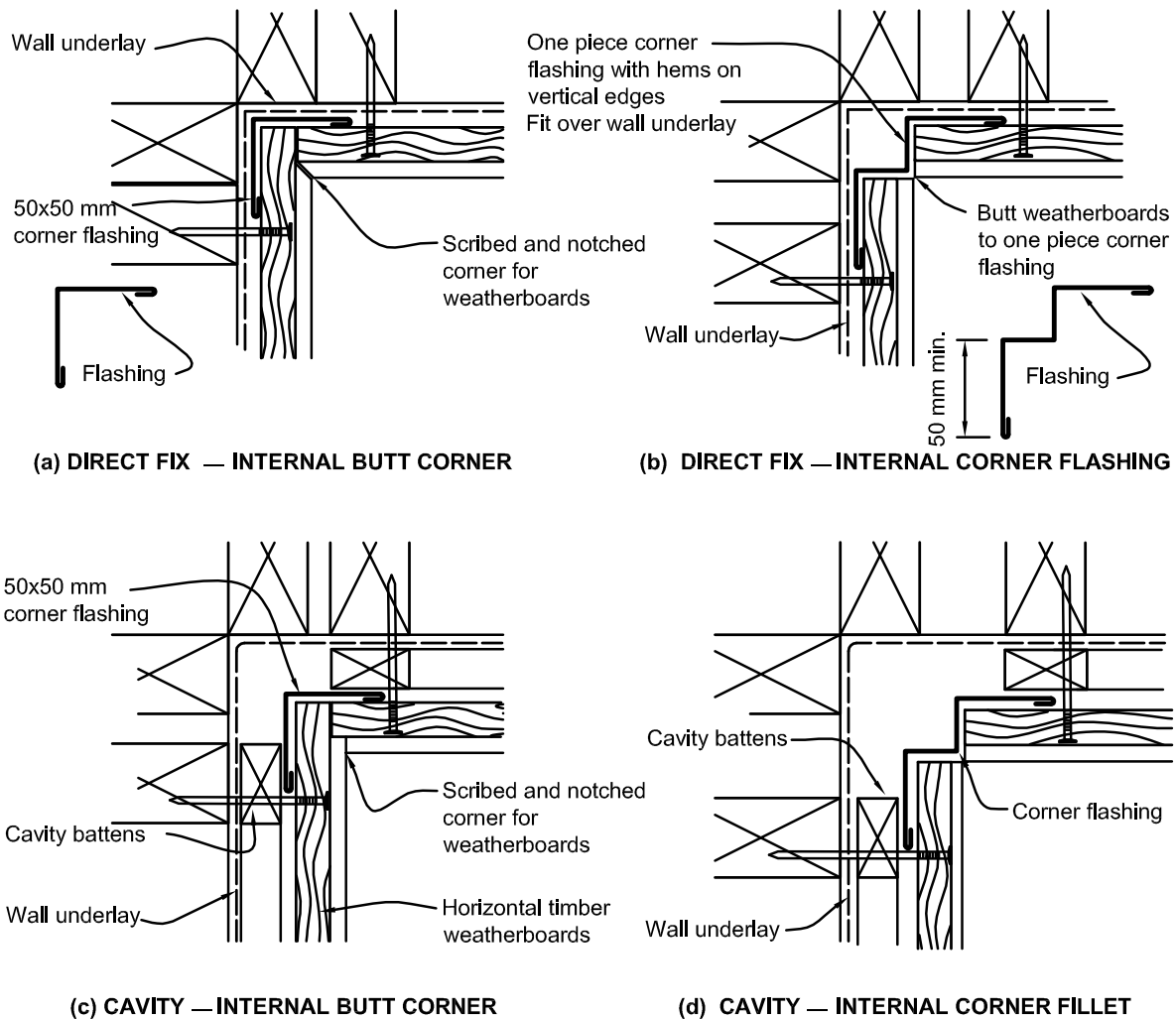

9.4.5 Vertical weatherboards

- 9.4.5.1 Vertical shiplap and board and batten weatherboards shall be in continuous lengths over a storey height.
- 9.4.5.2 Vertical shiplap weatherboards shall be fitted with a minimum gap of 2 mm at the overlap between boards.
- 9.4.5.3 Board and batten weatherboards shall:
- be fitted with a 5 mm to 8 mm gap between boards; and
 - have weather grooves to boards and battens aligned.
- 9.4.5.4 Vertical weatherboards shall be fixed to *dwangs* at 480 mm maximum centres in accordance with Table C.3.1.1.
- 9.4.5.5 External corners shall be weatherproofed by the use of corner facings as shown in Figure 9.4.5.5.
- 9.4.5.6 A corrosion-resistant corner *flashing*, as per Table 4.5.1.1 and Figure 9.4.4.5, shall be fitted behind the weatherboards at all internal corners.

Wall claddings

Figure 9.4.5.5: External corners for vertical weatherboards

Paragraph 9.4.5.5

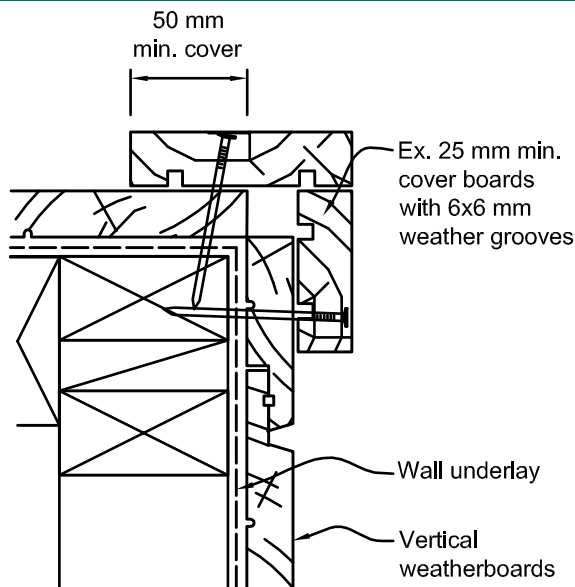

9.4.6 Windows and doors in direct fixed weatherboards

9.4.6.1 Window and door details for:

- a) *direct fixed* bevel-back weatherboards are shown in [Figure 9.4.6.1A](#); and
- b) *direct fixed* rusticated weatherboards are shown in [Figure 9.4.6.1B](#); and
- c) vertical shiplap weatherboards are shown in [Figure 9.4.6.1C](#); and
- d) vertical board and batten weatherboards are shown in [Figure 9.4.6.1D](#).

9.4.6.2 Door sill details are as shown in [Figure 9.1.10.3](#).

9.4.7 Windows and doors in cavity walls

9.4.7.1 Window and door details for bevel-back weatherboards on a *drained cavity* shall be as shown in [Figure 9.4.7.1](#).

9.4.7.2 Window and door details for rusticated weatherboards on a *drained cavity* are shown in [Figure 9.4.7.2](#).

9.4.7.3 Door sill details are as shown in [Figure 9.1.10.4](#).

COMMENT: The junctions around windows are critical, and it is important that responsibility is taken for the *weathertightness* of the window as installed within *external walls*.

Care should be taken to ensure that this responsibility is clearly defined and assigned. One way is to clearly specify that the window manufacturer shall be responsible for the supply and installation of *flashings* and frames into openings.

Wall claddings

Figure 9.4.6.1A: Windows and doors for direct fixed bevel-back weatherboards

Paragraphs [4.5.5.1](#), [9.1.5.1](#), [9.4.6.1](#), and [Table 4.5.1.1](#)

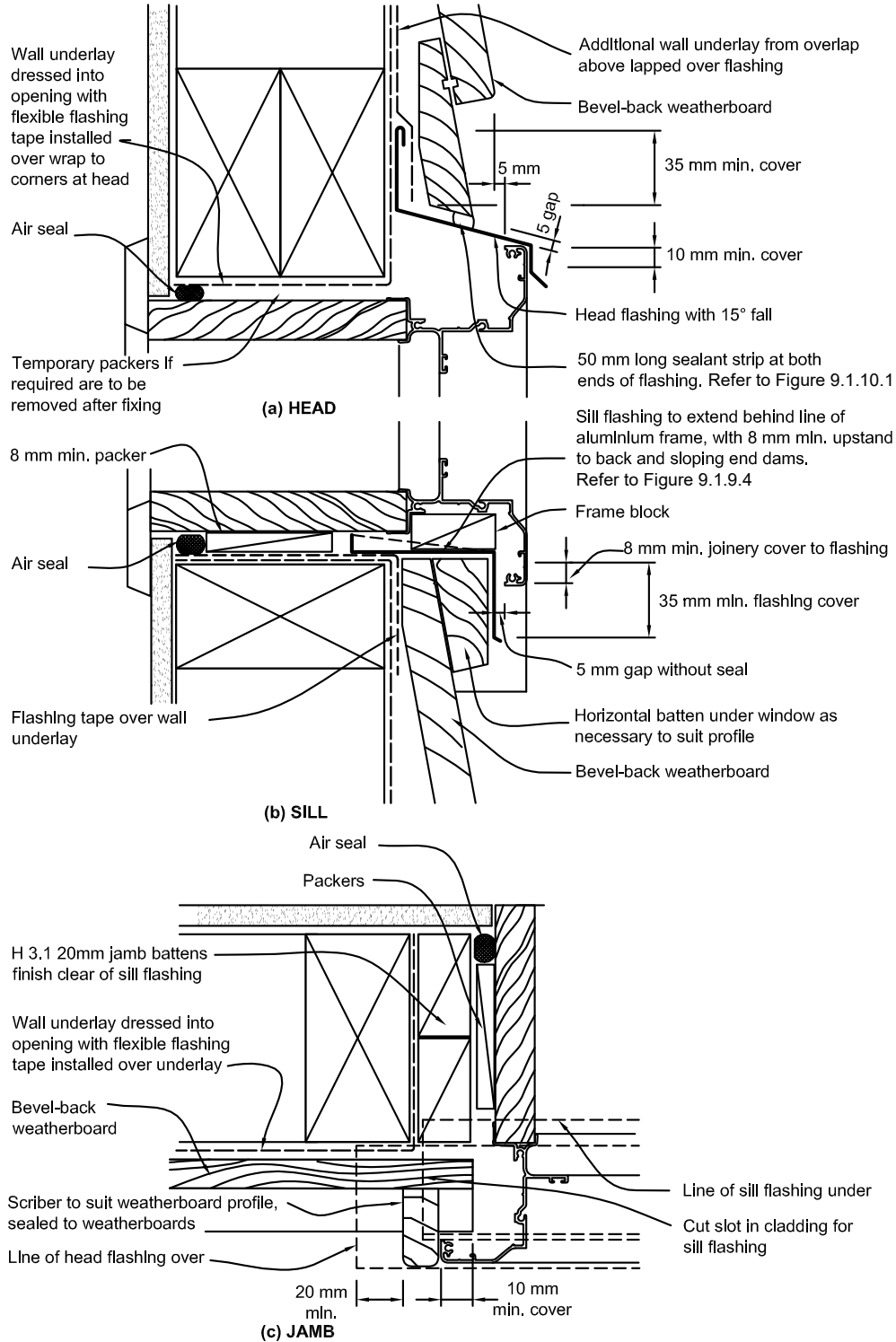

- Notes:** (1) Window profile to be selected to achieve the cover shown in the details.
 (2) Architraves are shown for consistency only. The details may be used with rebated liner.
 (3) For wrapping of a framed opening prior to window installation, refer to [Figure 9.1.9.4](#).

Wall claddings

Figure 9.4.6.1B: Windows and doors for direct fixed rusticated weatherboards

Paragraph 9.4.6.1

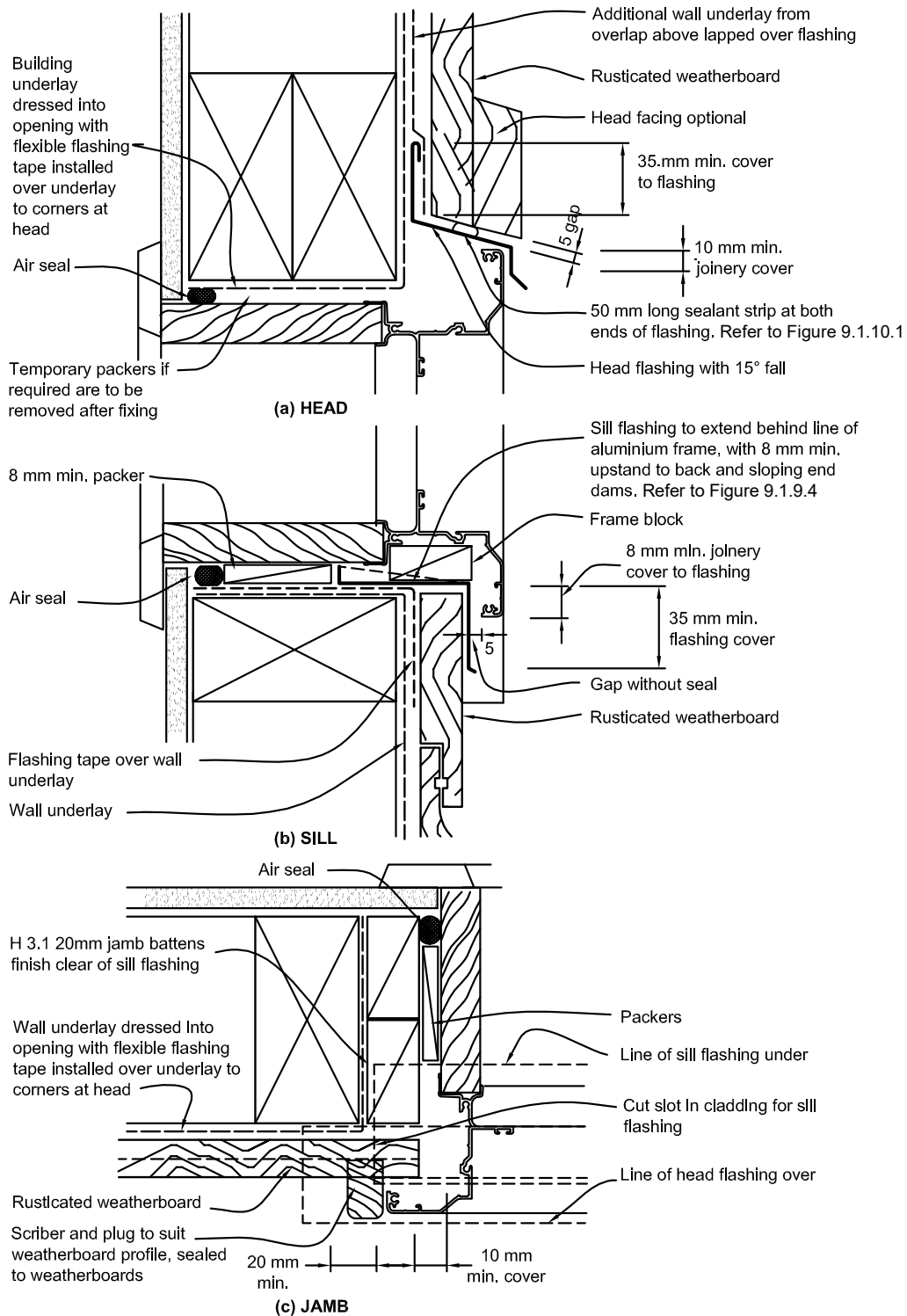

- Notes:** (1) Window profile to be selected to achieve the cover shown in the details.
 (2) Architraves are shown for consistency only. The details may be used with rebated liner.
 (3) For wrapping of a framed opening prior to window installation, refer to [Figure 9.1.9.4](#).

Wall claddings

Figure 9.4.6.1C: Windows and doors for direct fixed vertical shiplap weatherboards
 Paragraph 9.4.6.1

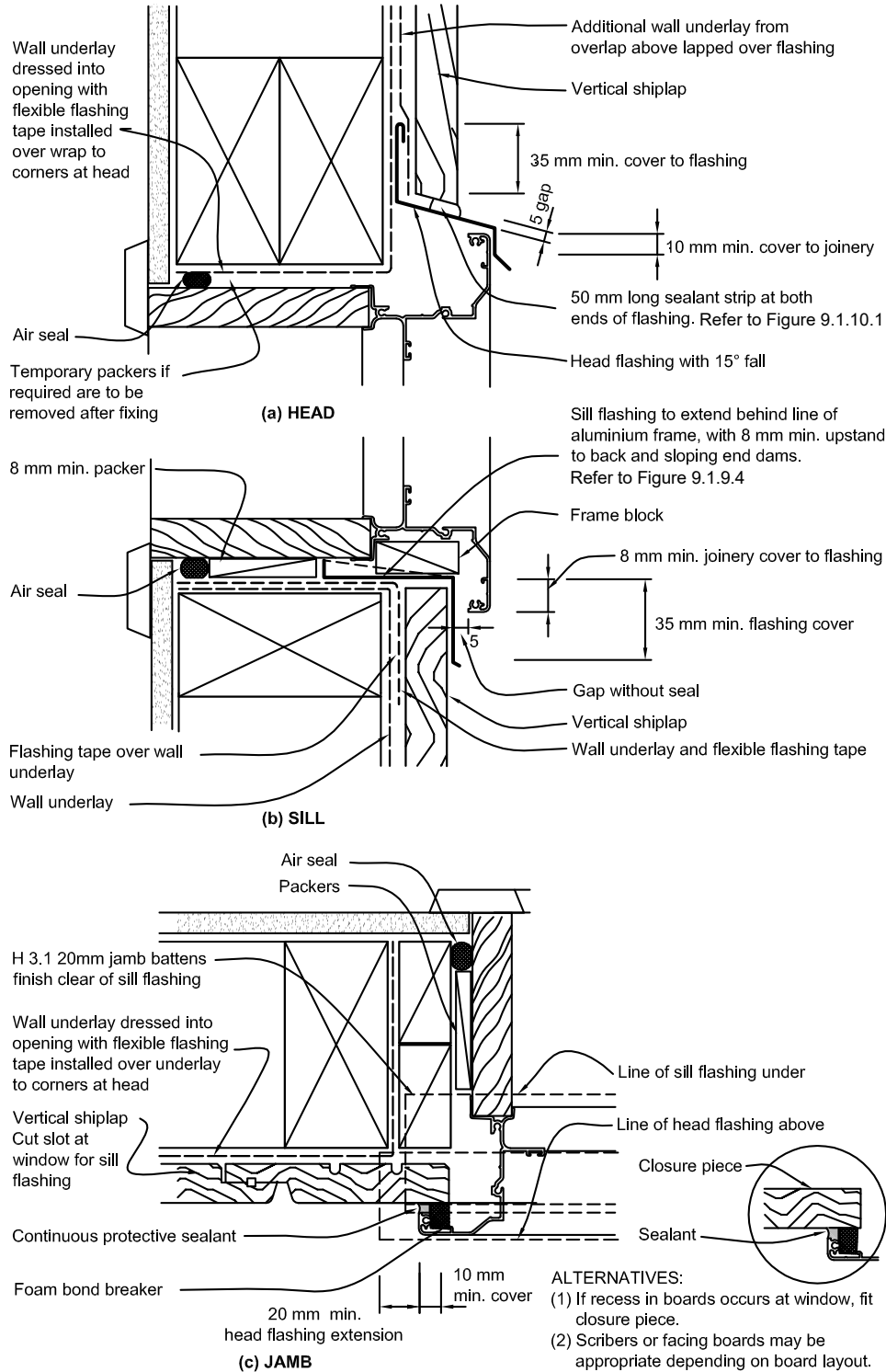

- Notes:** (1) Window profile to be selected to achieve the cover shown in the details.
 (2) Architraves are shown for consistency only. The details may be used with rebated liner.
 (3) For wrapping of a framed opening prior to window installation, refer to [Figure 9.1.9.4](#).

Wall claddings

Figure 9.4.6.1D: Windows and doors for direct fixed board and batten weatherboards
 Paragraph 9.4.6.1

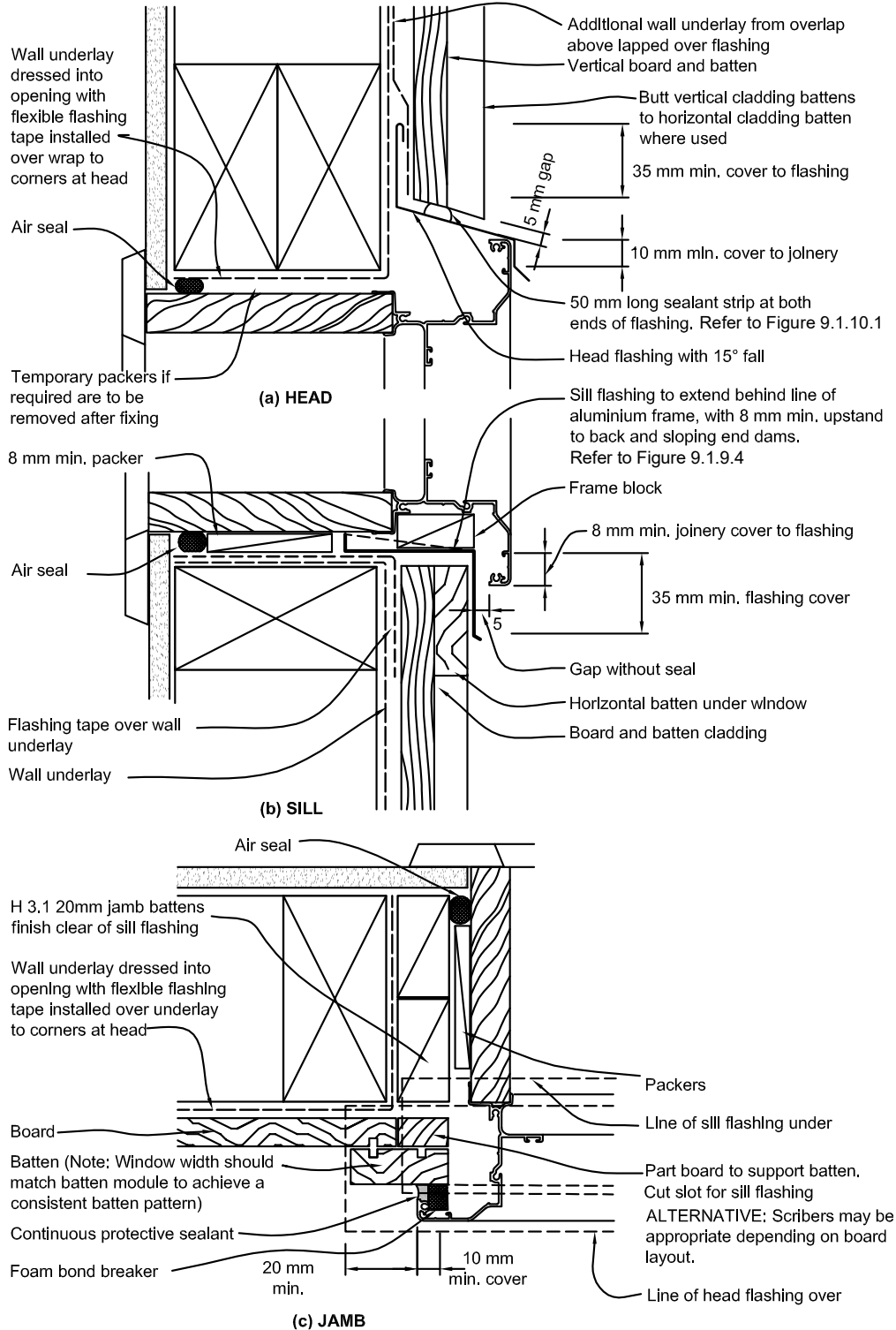

- Notes:** (1) Window profile to be selected to achieve the cover shown in the details.
 (2) Architraves are shown for consistency only. The details may be used with rebated liner.
 (3) For wrapping of a framed opening prior to window installation, refer to [Figure 9.1.9.4](#).

Wall claddings

Figure 9.4.7.1: Windows and doors for bevel-back weatherboards on cavity

Paragraph 9.4.7.1

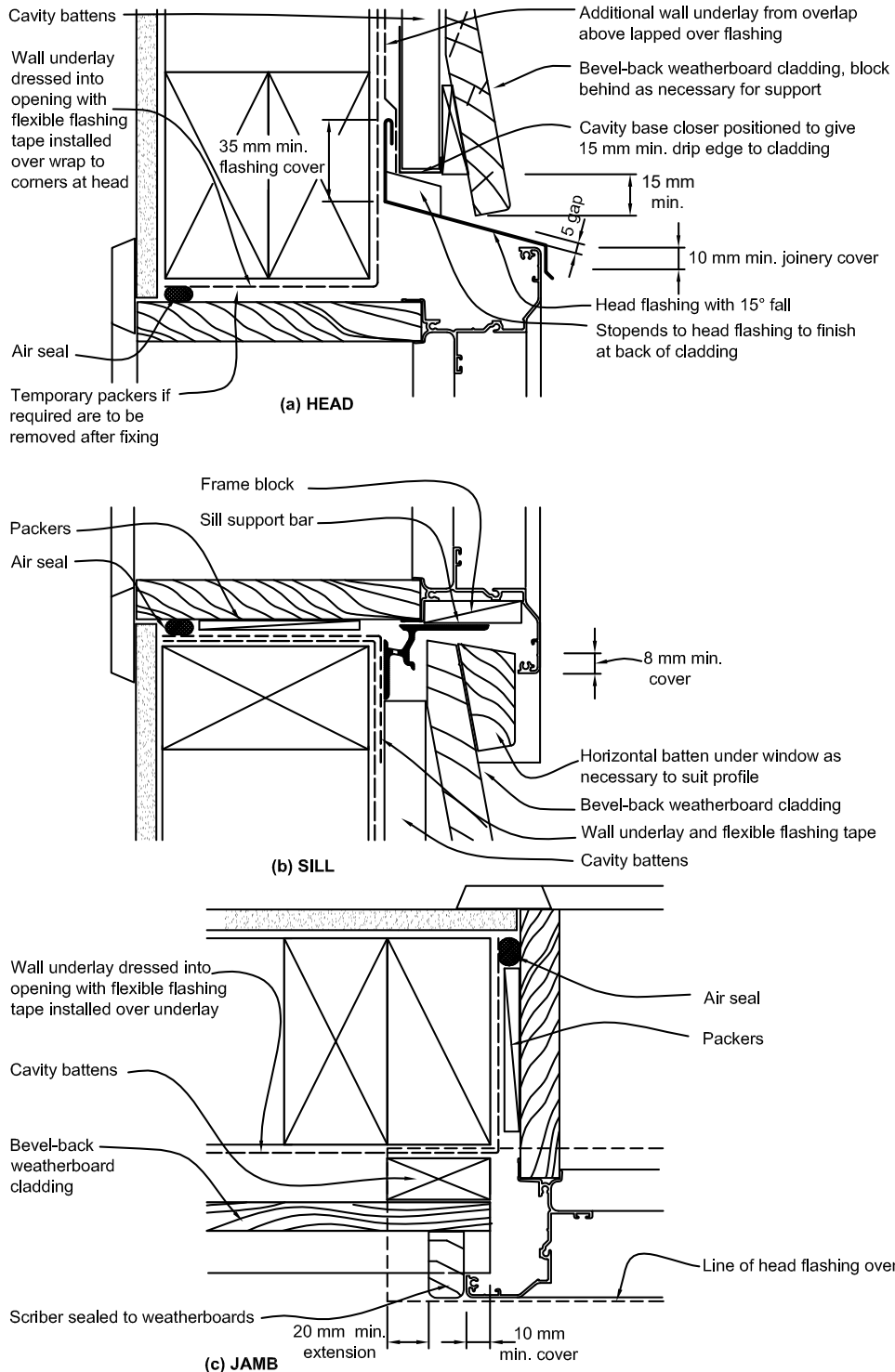

- Notes:** (1) Window profile to be selected to achieve the cover shown in the details.
 (2) Architraves are shown for consistency only. The details may be used with rebated liner.
 (3) A sill support bar conforming to EM6 and Paragraph 9.1.10.4 is required. Refer to [Figure 9.1.9.6](#).
 (4) For sealant at head for Very High and Extra High wind zones, refer to [Figure 9.1.10.1\(c\)](#).

Wall claddings

Figure 9.4.7.2: Windows and doors for rusticated weatherboards on cavity
Paragraph 9.4.7.2

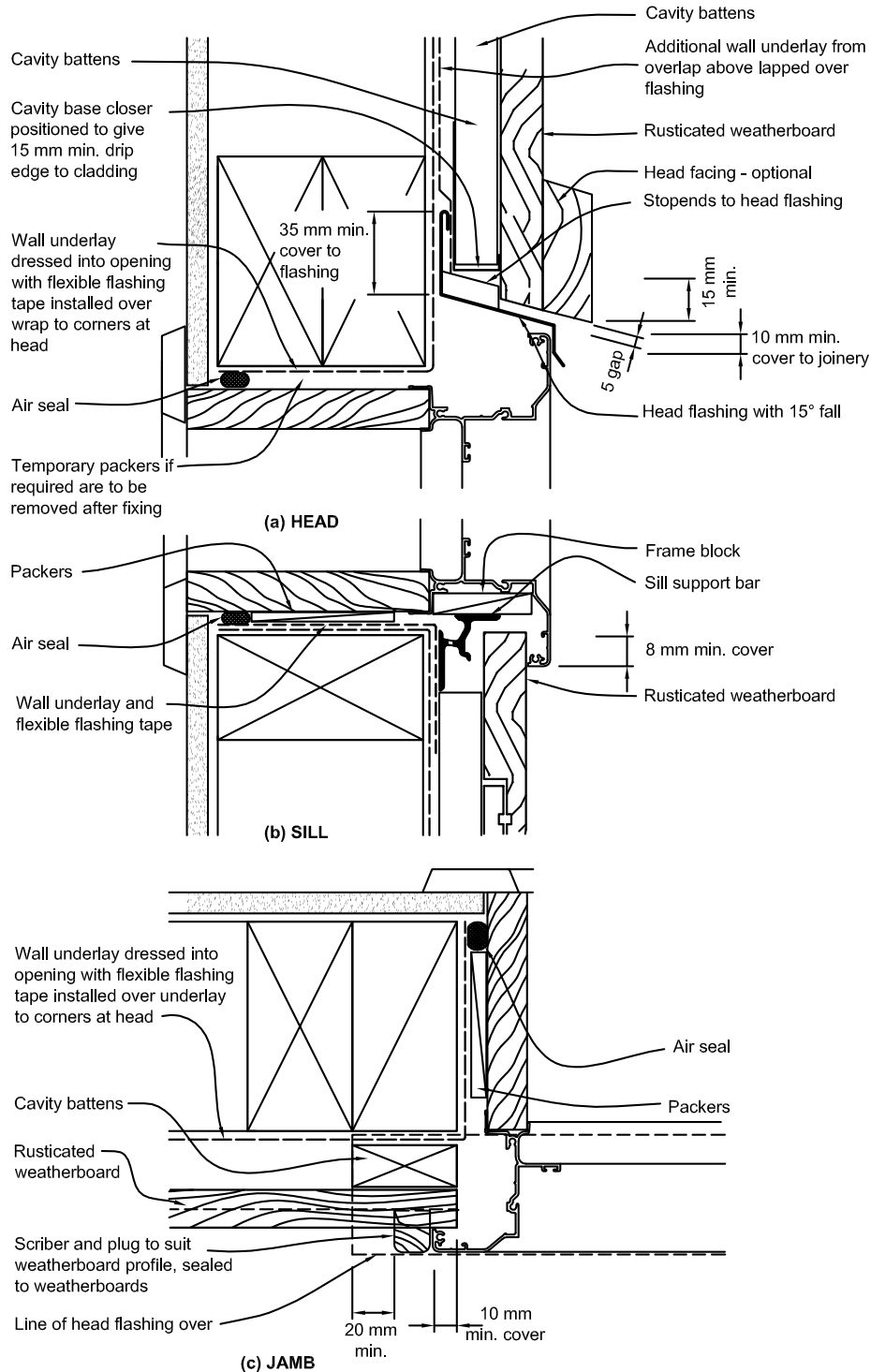

- Notes:** (1) Window profile to be selected to achieve the cover shown in the details.
 (2) Architraves are shown for consistency only. The details may be used with rebated liner.
 (3) A sill support bar conforming to EM6 and Paragraph 9.1.10.4 is required. Refer to [Figure 9.1.9.6](#).
 (4) For sealant at head for Very High and Extra High wind zones, refer to [Figure 9.1.10.1\(c\)](#).

Wall claddings

9.4.8 Parapets and enclosed balustrades

- 9.4.8.1 *Parapets* shall be in accordance with [Part 6. Parapets](#).
- 9.4.8.2 *Enclosed balustrades* shall be in accordance with Section [7.5](#).

9.4.9 Finishes

- 9.4.9.1 Where a protective finish is required by NZS 3602, all timber surfaces, including end grain and laps, shall be sealed by priming.
- 9.4.9.2 Two coats of exterior grade paint shall be applied, after priming, to all exposed surfaces. Paint systems shall comply with any of Parts 7, 8, 9, or 10 of AS 3730.

COMMENT: The minimum durability period for protective coatings is 5 years. Improvement in durability and stability of weatherboards can be achieved by priming all surfaces including backs of boards.

Manufacturers of coatings which have a proven performance in use may be able to show compliance with Building Code clause B2 Durability as detailed in B2/VM1 as an alternative to compliance with AS 3730.

With tangentially-sawn weatherboards, particularly painted or stained in dark colours, cupping is possible. Providing additional fixings may help restrain the board, but will usually result in splitting of the boards.

9.5 Fibre cement weatherboards

9.5.1 Use and limitations

- 9.5.1.1 Fibre cement weatherboards shall be flat weatherboards with a minimum thickness of 7.5 mm.
- 9.5.1.2 Fibre cement weatherboard *claddings* shall be either *direct fixed* to framing over a *wall underlay*, or fixed over a *drained cavity* as described in Subsection [9.1.7](#).
- 9.5.1.3 Based on the *risk score* for the *external wall*, calculated as per Section [3.1](#), the fibre cement weatherboard *cladding* may require the inclusion of a *drained cavity*.

9.5.2 Materials

- 9.5.2.1 Fibre cement weatherboards shall comply with Subsection 4.2.1 of the Building Product Specifications.

9.5.3 Installation

- 9.5.3.1 A *wall underlay*, as specified in [Table C.2.1.1](#) and Subsections [9.1.4](#), [9.1.5](#), and [9.1.6](#), shall be installed behind fibre cement weatherboard *claddings*.
- 9.5.3.2 Fibre cement weatherboards shall be fixed through the *wall underlay* to the *framing* at maximum 600 mm centres as per [Table C.3.1.1](#).
- 9.5.3.3 Horizontal laps shall be a minimum of 30 mm.
- 9.5.3.4 Joints shall be:
 - a) positioned between *studs*; and
 - b) staggered at a minimum of 600 mm from joints in the adjacent boards.
- 9.5.3.5 Joints shall be weatherproofed by:
 - a) uPVC H jointers as shown in [Figure 9.5.3.5](#); or
 - b) hidden soakers as shown in [Figure 9.5.3.5](#), with sealant used between ends of boards complying with:
 - i) Type F, Class 20LM, or 25LM of ISO 11600, or
 - ii) low modulus Type II Class A of Federal Specification TT-S-00230C.

Wall claddings

9.5.3.6 External corners shall be weatherproofed as shown in [Figure 9.5.3.6](#) by:

- the use of corrosion-resistant soakers complying with Subsections [4.2.1](#), [4.2.2](#), [4.2.3](#), [4.2.4](#), [4.2.5](#), [4.2.6](#), and [4.2.7](#); or
- boxed corner facings with scribes.

9.5.3.7 Internal corners shall be weatherproofed by metal corner *flashings* as shown in [Figure 9.5.3.7](#).

Figure 9.5.3.5: Joints in fibre cement weatherboards

Paragraph [9.5.3.5](#)

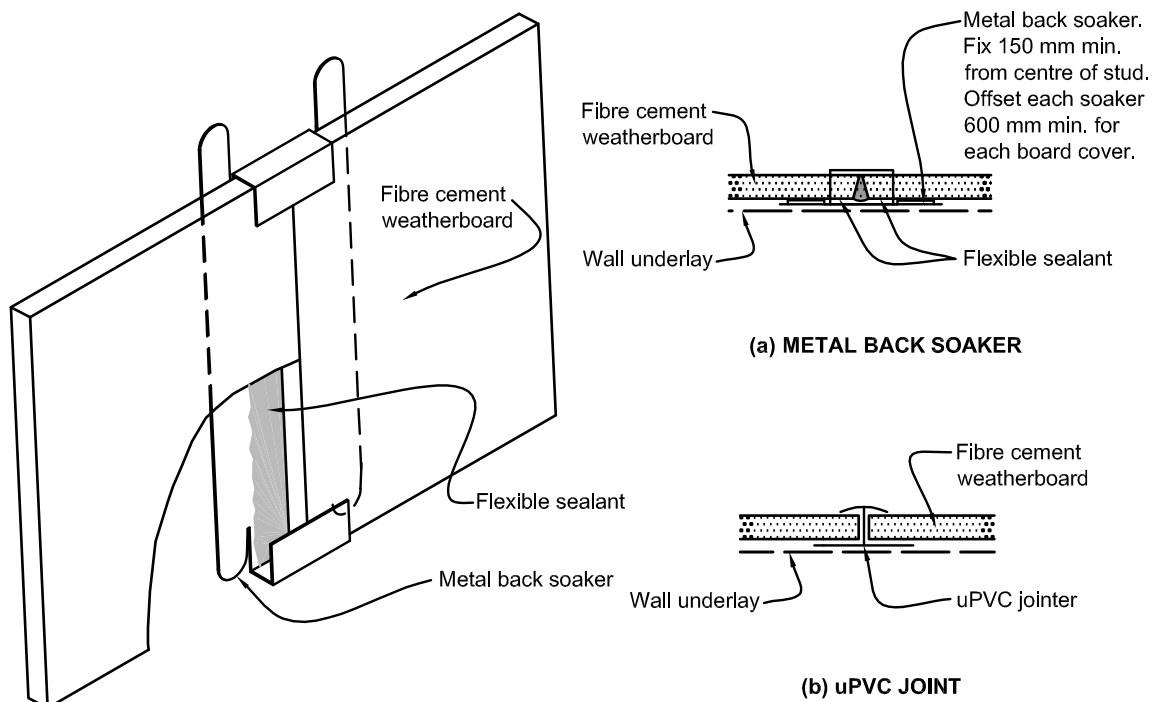
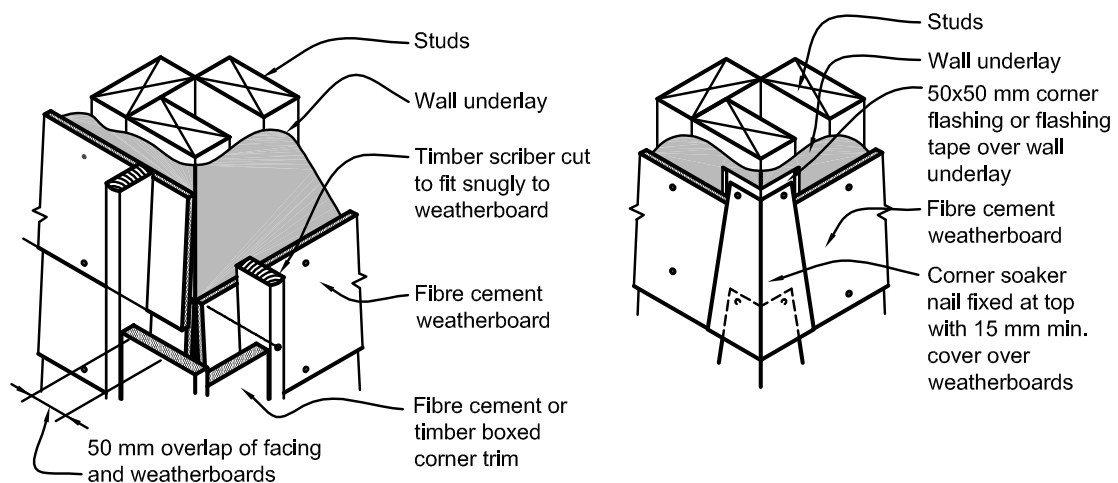

Figure 9.5.3.6: External corners in fibre cement weatherboards

Paragraph [9.5.3.6](#) and [Figure 9.4.4.4A](#)



Notes:

- Boxed external corner details for cavity walls are similar.
- Soaker corners for cavity walls are similar to [Figure 9.4.4.4A](#).

Wall claddings

Figure 9.5.3.7: Aluminium corners in fibre cement weatherboards

Paragraph [9.5.3.7](#)

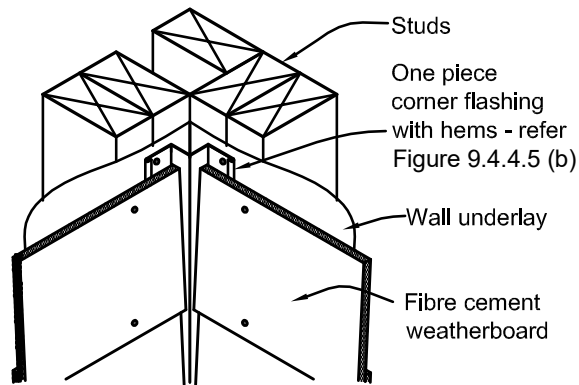

Note: (1) Corner details for cavity walls are similar.

9.5.4 Windows and doors

9.5.4.1 Windows and doors shall be installed in accordance with Subsections [9.1.9](#) and [9.1.10](#).

9.5.4.2 For *direct fixed* fibre cement weatherboards, windows and doors shall be detailed as shown in [Figure 9.5.4.2](#) and [Figure 9.1.10.3](#).

9.5.4.3 For fibre cement weatherboards fixed over a *drained cavity*, windows and doors shall be detailed as shown in [Figure 9.5.4.3](#) and [Figure 9.1.10.4](#).

9.5.5 Parapets and enclosed balustrades

9.5.5.1 *Parapets* shall be in accordance with [Part 6. Parapets](#).

9.5.5.2 *Enclosed balustrades* shall be in accordance with Section [7.5](#).

9.5.6 Protective coating

9.5.6.1 The exposed faces, including top edges at sills and all bottom edges, of horizontal fibre cement weatherboards shall be finished with a minimum of a 2-coat latex exterior paint system complying with any of Parts 7, 8, 9, or 10 of AS 3730.

Wall claddings

Figure 9.5.4.2: Windows and doors in fibre cement direct fixed weatherboards

Paragraph 9.5.4.2

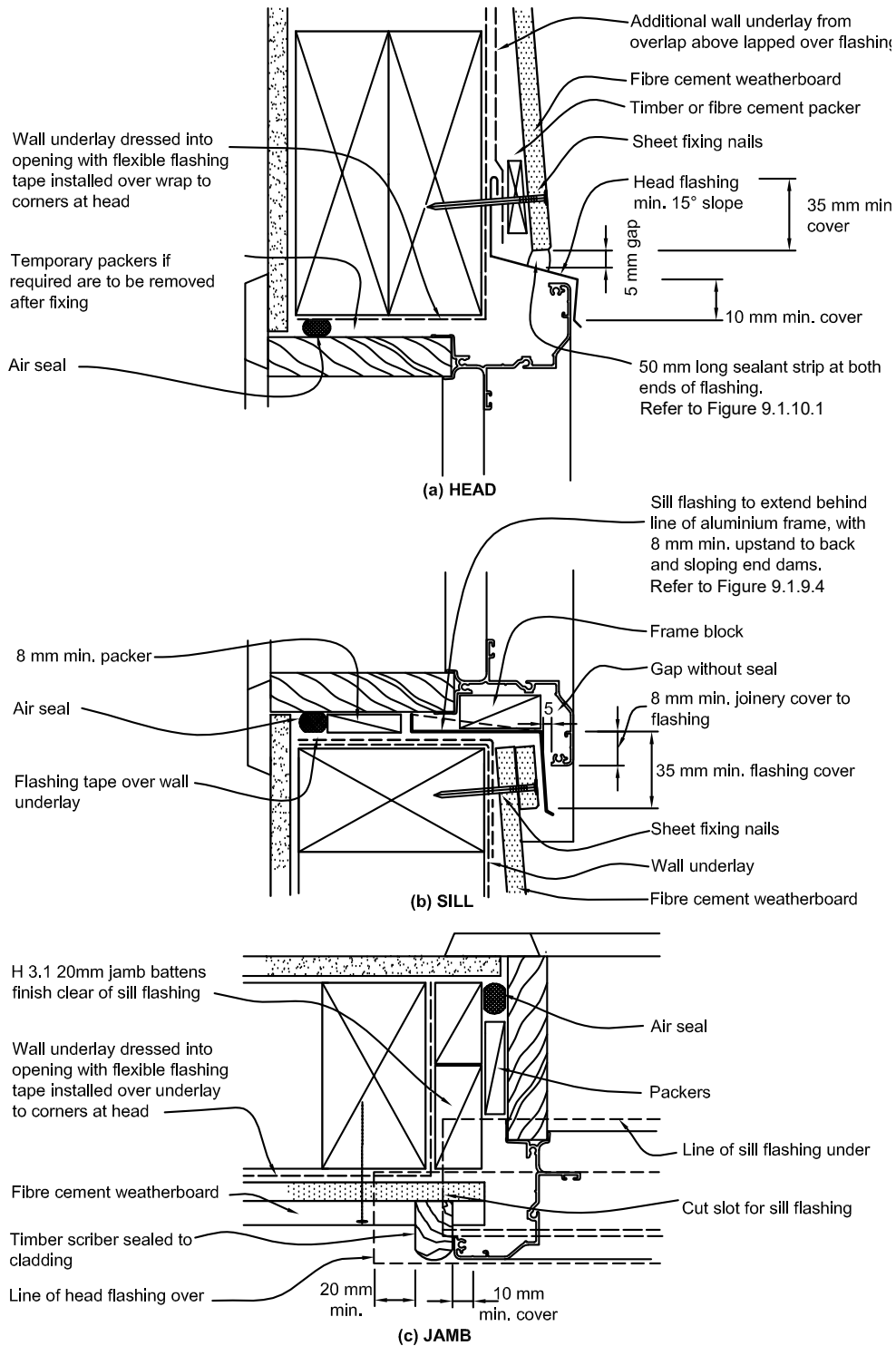

- Notes:** (1) Window profile to be selected to achieve the cover shown in the details.
 (2) Architraves are shown for consistency only. The details may be used with rebated liner.
 (3) For wrapping of a framed opening prior to window installation, refer to [Figure 9.1.9.4](#).

Wall claddings

Figure 9.5.4.3: Windows and doors in fibre cement weatherboards on cavity

Paragraph 9.5.4.3

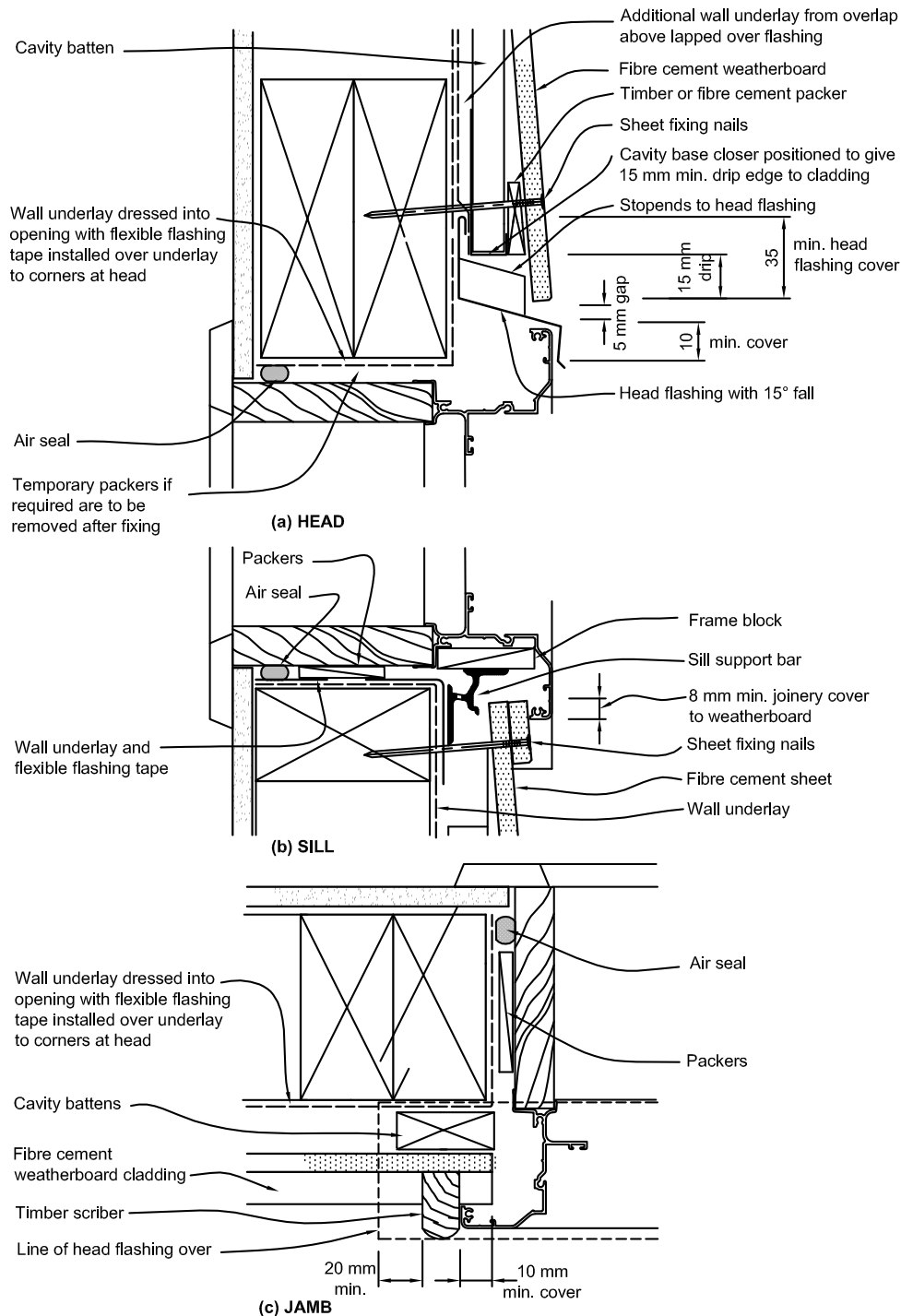

- Notes:** (1) Window profile to be selected to achieve the cover shown in the details.
 (2) Architraves are shown for consistency only. The details may be used with rebated liner.
 (3) A sill support bar conforming to EM6 and Paragraph 9.1.10.4 is required. Refer to [Figure 9.1.9.6](#).
 (4) For wrapping of a framed opening prior to window installation, refer to [Figure 9.1.9.6](#).
 (5) For sealant at head for Very High and Extra High wind zones, refer to [Figure 9.1.10.1\(c\)](#).

Wall claddings

9.6 Profiled metal wall cladding

9.6.1 Use and limitations

- 9.6.1.1 This section contain provisions for profiled metal *cladding*. Profiled metal *wall cladding* shall be corrugated or *trapezoidal* metal *wall cladding* with the profiles, as shown in [Figure 8.4.3.1](#), and applied as outlined in [Table 3.1.3.2](#).
- 9.6.1.2 Horizontal profiled metal *wall cladding* shall be fixed over a *drained cavity* as described in Subsection [9.1.7](#) and shall only be used in the risk categories where the selected profile is shown in [Table 3.1.3.2](#).
- 9.6.1.3 Vertical profiled metal *wall cladding* shall be direct fixed to *framing* over a *roof underlay* and shall only be used in the risk categories where the selected profile is shown in [Table 3.1.3.2](#).

9.6.2 Materials

- 9.6.2.1 The metal cladding shall be selected according to the intended exposure zone in [Table C.1.1.1A](#).

COMMENT: The exposure zone in which a *building* is located can affect the durability of *flashings*.

Exposure zones are defined in NZS 3604, based on the likely exposure to wind-driven sea-salt. Corrosion due to geothermal or corrosive industrial atmospheres, as defined in NZS 3604, requires *specific design*.

Exposure zones are based on AS/NZS 2728. AS/NZS 2728 lists atmospheric classes derived from ISO 9223 for Australia and New Zealand.

- 9.6.2.2 Materials for the manufacture of profiled steel cladding shall:
- have a BMT of 0.4 mm minimum; and
 - be grade G550, or G300 for curved and crimped cladding; and
 - be coated, or coated and factory painted, to provide the corrosion protection required by Paragraph [9.6.2.1](#).
- 9.6.2.3 Aluminium for the manufacture of profiled aluminium wall *cladding* shall comply with AS/NZS 1734, and be:
- a *base metal thickness (BMT)* of a minimum of 0.7 mm; and
 - minimum 5000 series.
- 9.6.2.4 For pre-painted aluminium, a factory-applied finish complying with AS/NZS 2728 shall be applied.

9.6.3 Profiles

- 9.6.3.1 Profiles covered in this acceptable solution are:
- corrugated – curved with a minimum crest height of 16.5 mm minimum; and
 - trapezoidal* – symmetrical and asymmetrical with a minimum crest height of 19 mm.
- 9.6.3.2 For details of these profiles, refer to [Figure 8.4.3.1](#).

9.6.4 Fixings

- 9.6.4.1 The *cladding* shall be screw-fixed through the troughs, and the cavity battens for horizontal profiled metal, into the *framing*. Fixings shall:
- be minimum 12-gauge hexagonal head, self-drilling wood screws; and
 - penetrate the framing by a minimum of 30 mm; and
 - be minimum Class 4 to AS 3566.2, selected from [Table C.1.1.1A](#); and

Wall claddings

- d) include neoprene (having a carbon black content of 15% or less by weight) or EPDM sealing washers as shown in [Figure 8.4.6.1](#); and
- e) be used on the *cladding* at side laps and every second trough or, for *trapezoidal* where the rib centres exceed 150 mm, at side laps and every trough:
 - i) to *framing*, and
 - ii) at all external and internal corners.

9.6.5 Flashings

- 9.6.5.1 *Flashings* used with metal *wall cladding* shall be in accordance with [Part 4. Flashings](#).
- 9.6.5.2 *Hooks* and *hems* shall be as shown in [Figure 4.4.3.2](#).
- 9.6.5.3 *Flashings* shall have joints formed with laps and sealant as shown in [Figure 4.4.4.1](#).
- 9.6.5.4 Where shown, sealant shall be neutral cure, complying with:
 - a) Type F, Class 20LM, or 25LM of ISO 11600; or
 - b) low modulus Type II Class A of Federal Specification TT-S-00230C.
- 9.6.5.5 *Under-flashings* shall be fixed to framing at 600 mm maximum centres.
- 9.6.5.6 *Flashings* shall be fixed together at junctions at 50 mm maximum centres or to *cladding* at 900 mm centres with:
 - a) for galvanized steel, 4 mm diameter monel metal or stainless steel rivets, where compatible as per [Table C.1.1.1B](#); or
 - b) for aluminium-zinc-magnesium coated steel, 4 mm diameter aluminium rivets; or
 - c) for aluminium, 4 mm diameter aluminium rivets.

9.6.6 Vertical profile – direct fixed

- 9.6.6.1 For *direct fixed* vertical profile, the *wall underlay* shall be in accordance with the properties listed for *roof underlay* in [Table C.2.1.1](#).
- 9.6.6.2 For copper-based treated *framing* or *underlay*, refer to Paragraph [9.6.7.2](#).

COMMENT: In *direct fixed* metal *cladding*, the *wall underlay* will be in contact with the back of the vertical profiled metal *cladding*. *Underlay* is needed to separate treated timber from the back of the metal to minimise the risk of *electrolytic corrosion*.

- 9.6.6.3 *Barge flashings* shall be as shown in [Figure 9.6.6.3](#).
- 9.6.6.4 The bottom edge of the cladding shall overlap the foundation wall as described in Subsection [9.1.2](#) and as shown in [Figure 9.6.6.4](#).
- 9.6.6.5 *Direct fixed* vertical profiled metal *wall cladding* shall be over-flashed at external and internal corners as shown in [Figure 9.6.6.5](#). The cover of the *flashings* shall:
 - a) be dimensioned to suit the metal *wall cladding* profile; and
 - b) cover at least two crests for corrugated and single crests for other profiles; and
 - c) terminate as shown in [Figure 9.6.6.5](#).
- 9.6.6.6 Pipe penetrations shall be as per [Figure 8.4.12.3A](#).
- 9.6.6.7 The heads of larger penetrations shall be flashed in similar fashion to [Figure 9.1.8.3B](#), with head *flashings* adjusted to suit the profile and other *flashings* as per window and door details in relevant paragraphs.
- 9.6.6.8 Windows and doors in vertical profiled metal *claddings* shall be flashed as shown in [Figure 9.6.6.8](#) and [Figure 9.6.7.9B](#).

Wall claddings

9.6.6.9 Parapets and *enclosed balustrades* shall be as shown in [Figure 9.6.6.9](#) and comply with:

- [Part 6. Parapets](#) for parapets; or
- Section [7.5](#) for enclosed balustrades.

COMMENT: Side fixings of handrails or other attachments to *enclosed balustrades* or parapets will require *specific design* to demonstrate *weathertightness*, together with specific structural design for stanchion fixings.

Figure 9.6.6.3: Barge for vertical profiled metal

Paragraph [9.6.6.3](#)

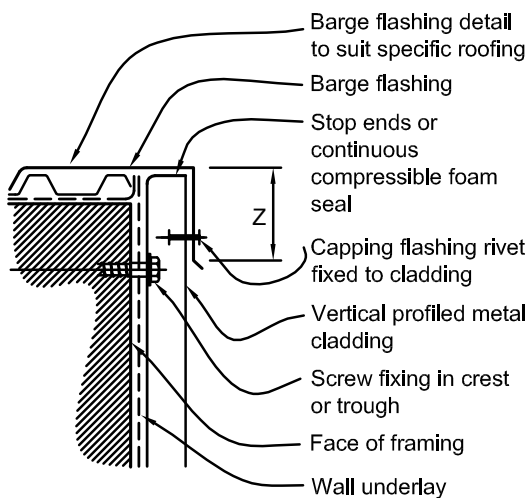

Note: (1) For dimension Z, refer to [Table 4.5.1.1](#)

Figure 9.6.6.4: Bottom of cladding for vertical profiled metal

Paragraph [9.6.6.4](#)

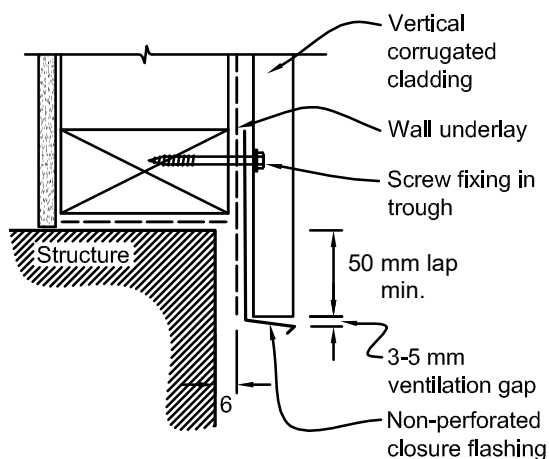

Note: (1) Refer to Subsection [9.1.2](#) for ground clearances.

Wall claddings

Figure 9.6.6.5: Corners for vertical profiled metal

Paragraph 9.6.6.5

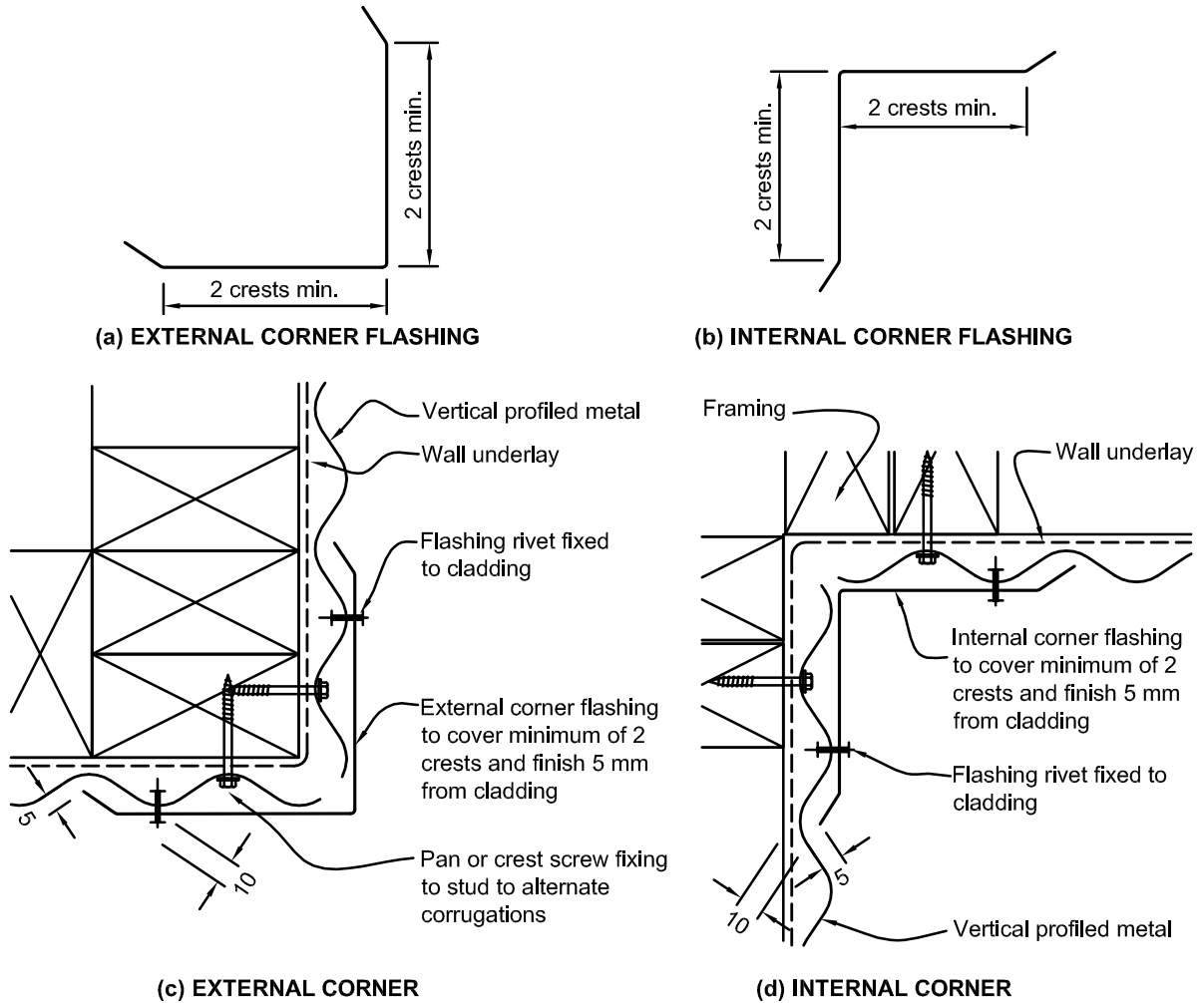

Wall claddings

Figure 9.6.6.8: Windows and doors for vertical profiled metal

Paragraph 9.6.6.8 and Figure 9.6.7.9B, and Table 4.5.1.1

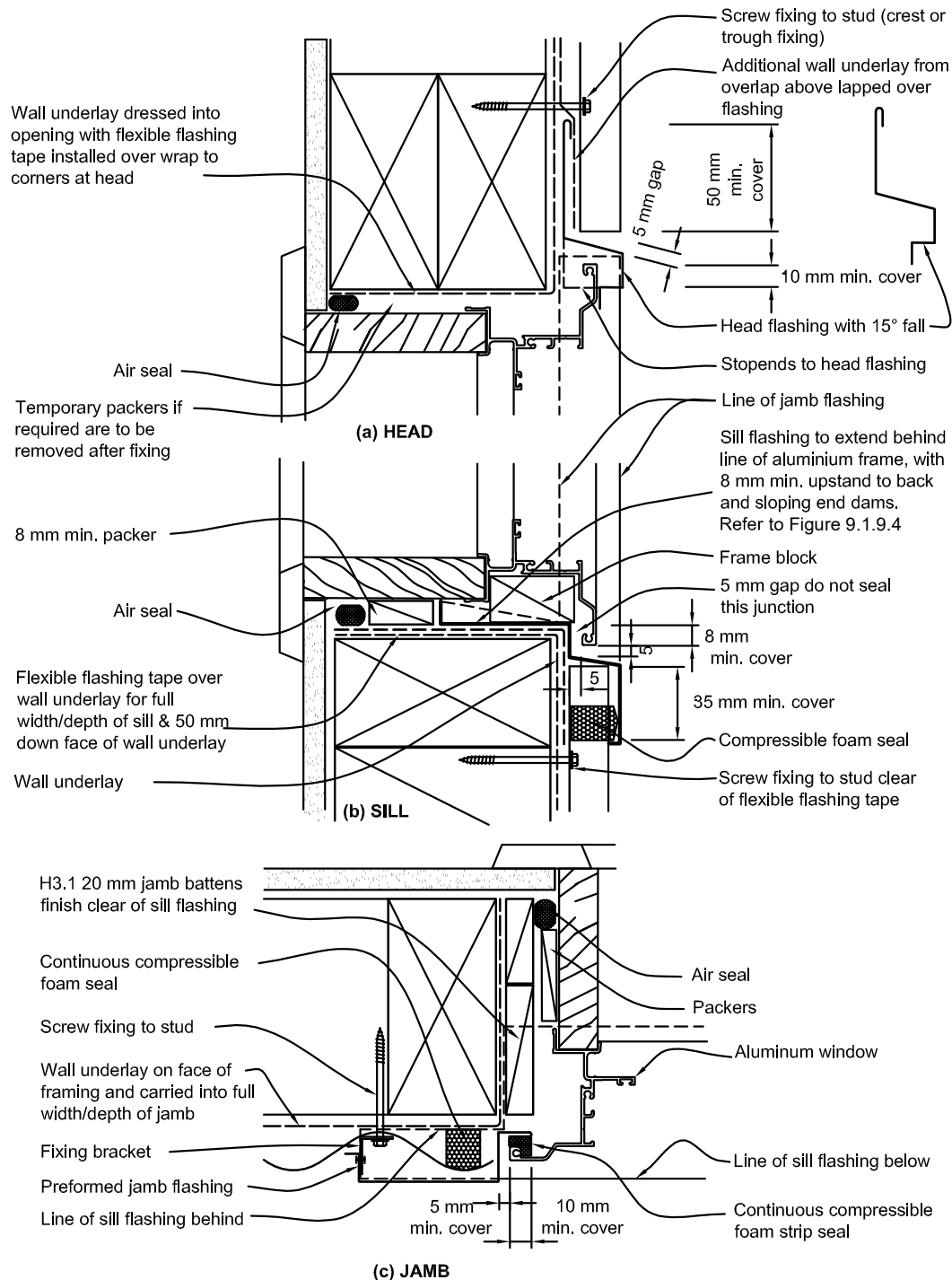

- Notes:** (1) Window profile to be selected to achieve the cover shown in the details.
 (2) Architraves are shown for consistency only. The details may be used with rebated liner.
 (3) A sill support bar conforming to EM6 and Paragraph 9.1.10.4 is required. Refer to Figure 9.1.9.6.
 (4) For wrapping of a framed opening prior to window installation, refer to Figure 9.1.9.4.
 (5) For sealant at head for Very High and Extra High wind zones, refer to Figure 9.1.10.1(c).

Wall claddings

Figure 9.6.6.9: Balustrade and parapet for vertical profiled metal

Paragraph 9.6.6.9

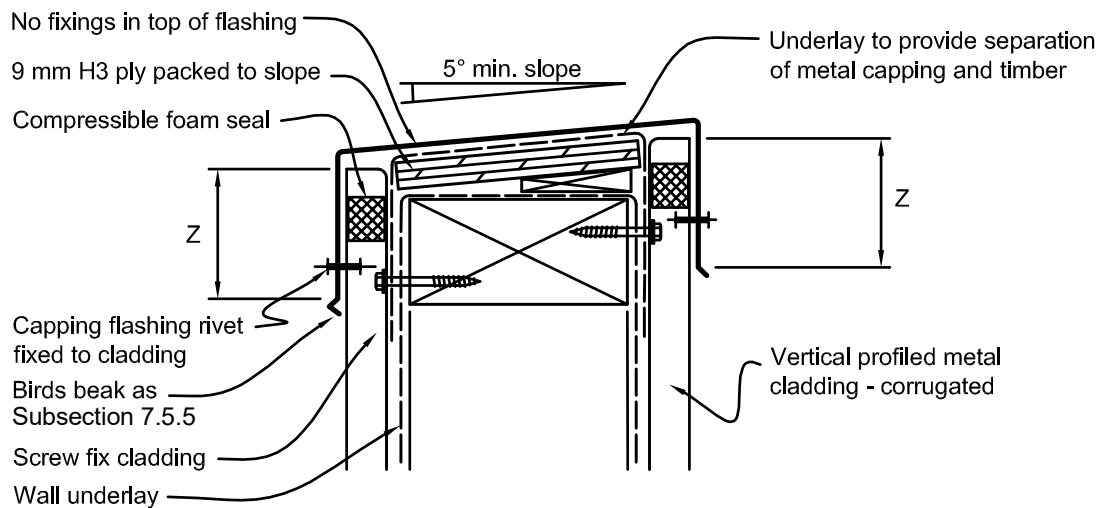

Notes: (1) For dimension Z, refer to [Table 4.5.1.1](#)

9.6.7 Horizontal profile metal on cavity

- 9.6.7.1 A wall underlay, as specified in [Table C.2.1.1](#) and Subsections [9.1.4](#), [9.1.5](#), and [9.1.6](#), shall be installed over the outside face of the *framing*.
- 9.6.7.2 If the *cavity batten* contains copper (e.g. CCA, copper azole, or ACQ), appropriate separation between the back of the *cladding* and the *cavity batten* shall be provided. Examples of suitable separation are:
- an additional layer of paper-based *underlay*, complying with [Table C.2.1.1](#), over *cavity battens*; or
 - strips of paper-based *underlay* complying with [Table C.2.1.1](#) on the face of *cavity battens*; or
 - pre-priming *cavity battens*.
- 9.6.7.3 Corners shall be weatherproofed by using the *flashings* and details shown in [Figure 9.6.7.3](#).
- 9.6.7.4 Horizontal profiled metal *wall cladding* shall be under-flashed at corners using *butt flashings* that shall:
- be formed in one shaped piece; and
 - allow metal cladding to butt, with a separation of 5 mm, against sides of the exposed *flashing* corner; and
 - use profiled compressible foam to seal between the *flashing* underlap and underside of *cladding*.
- 9.6.7.5 Barge *flashings* shall be as shown in [Figure 9.6.7.5](#).
- 9.6.7.6 The bottom edge of the *cladding* shall overlap the foundation *wall* as described in Subsection [9.1.2](#) and as shown in [Figure 9.6.7.6](#).
- 9.6.7.7 All services penetrations through *claddings* shall be flashed and sealed. Pipe penetrations are shown in [Figure 8.4.12.3A](#).
- 9.6.7.8 The heads of larger penetrations shall be flashed in a similar fashion to [Figure 9.1.8.3B](#).
- 9.6.7.9 Windows and doors shall be installed in accordance with Subsections [9.1.9](#) and [9.1.10](#), and as shown in [Figure 9.6.7.9A](#) and [Figure 9.6.7.9B](#).

Wall claddings

9.6.7.10 Parapets and enclosed balustrades shall be as shown in [Figure 9.6.7.10](#) and comply with:

- a) [Part 6. Parapets](#) for parapets; or
- b) Section [7.5](#) for enclosed balustrades.

COMMENT: Side fixings of *handrails* or other attachments to *enclosed balustrades* or *parapets* will require *specific design* to demonstrate *weathertightness*, together with specific structural design for *stanchion* fixings.

Figure 9.6.7.3: Corner flashings for horizontal profiled metal

Paragraph [9.6.7.3](#)

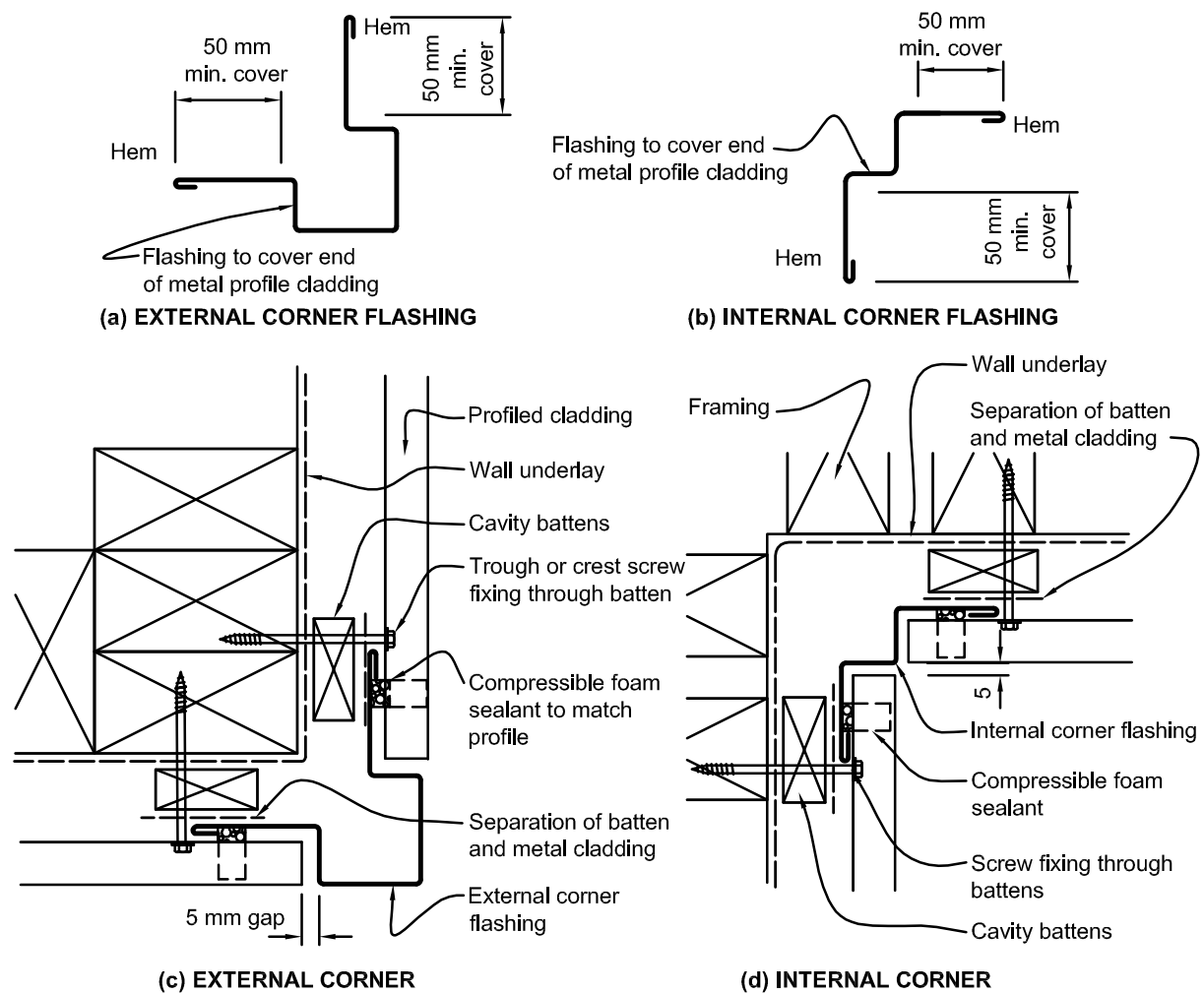

Wall claddings

Figure 9.6.7.5: Barge for horizontal profiled metal

Paragraph [9.6.7.5](#)

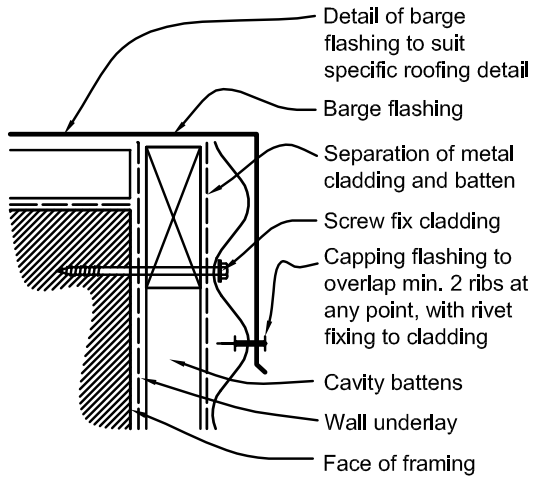
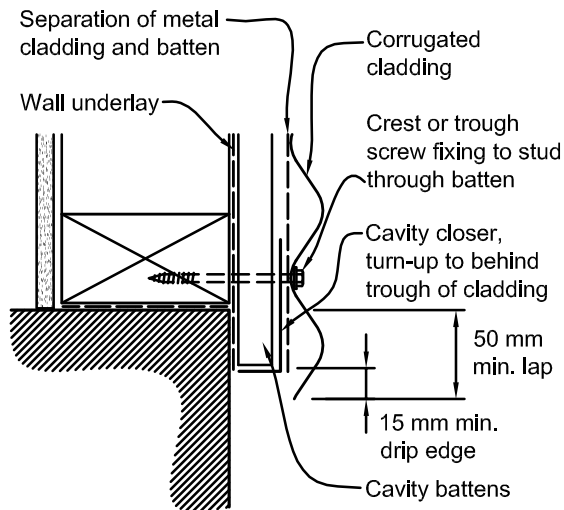

Figure 9.6.7.6: Bottom of cladding

Paragraph [9.6.7.6](#)



Notes:

- (1) A 6 mm offset of *framing* to the foundation is not necessary where *drained cavities* are used.
- (2) Refer to Subsection [9.1.2](#) for ground clearances.

Wall claddings

Figure 9.6.7.9A: Windows and doors for horizontal profiled metal on cavity

Paragraph 9.6.7.9 and Figure 9.6.7.9B, and Table 4.5.1.1

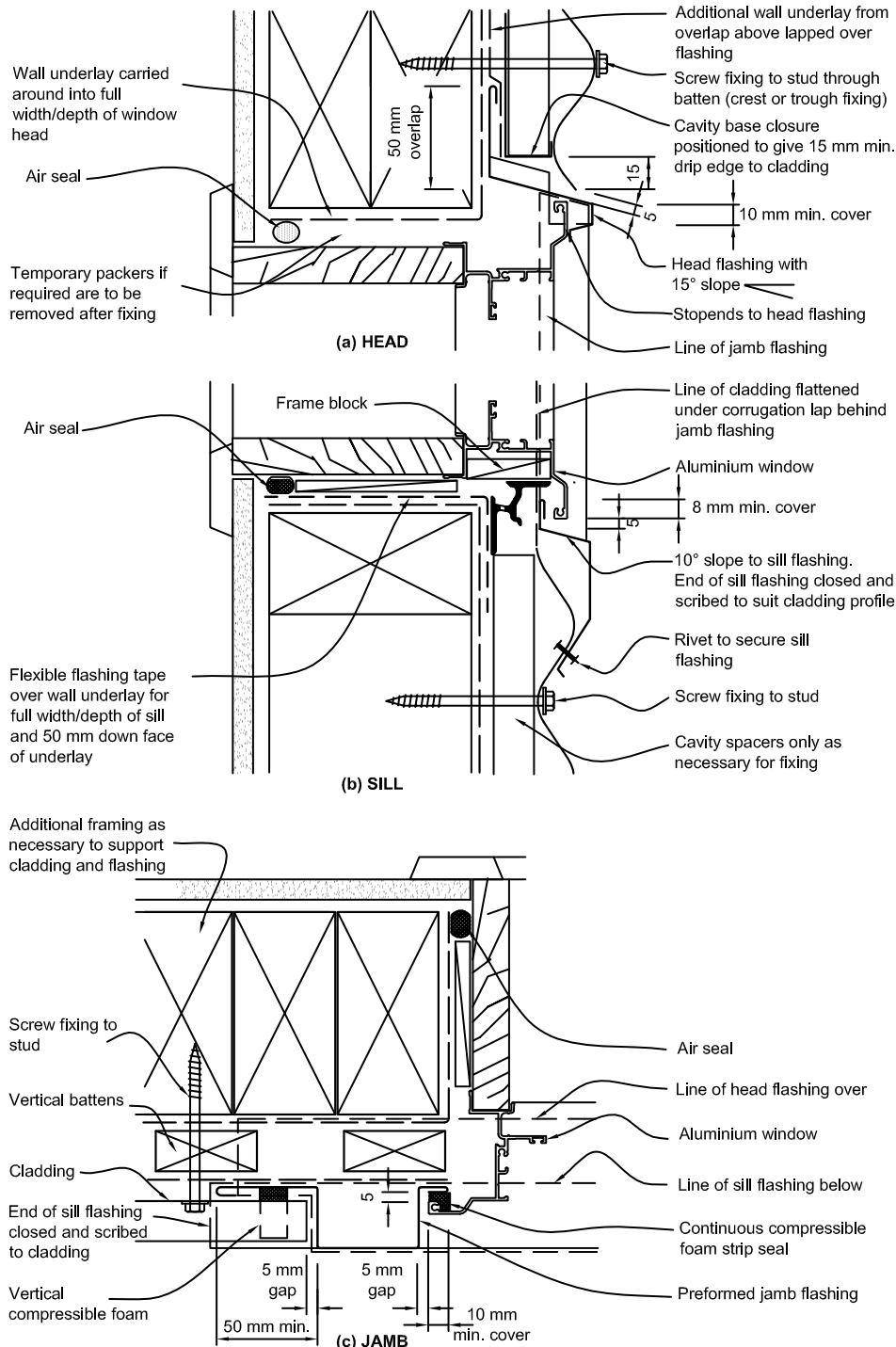

- Notes:** (1) Window profile to be selected to achieve the cover shown in the details.
 (2) Architraves are shown for consistency only. The details may be used with rebated liner.
 (3) A sill support bar conforming to EM6 and Paragraph 9.1.10.4 is required. Refer to Figure 9.1.9.6.
 (4) For wrapping of a framed opening prior to window installation, refer to Figure 9.1.9.6.
 (5) For sealant at head for Very High and Extra High wind zones, refer to Figure 9.1.10.1(c).

Wall claddings

Figure 9.6.7.9B: Window and door flashings for profiled metal
 Paragraphs [9.6.6.8](#) and [9.6.7.9](#)

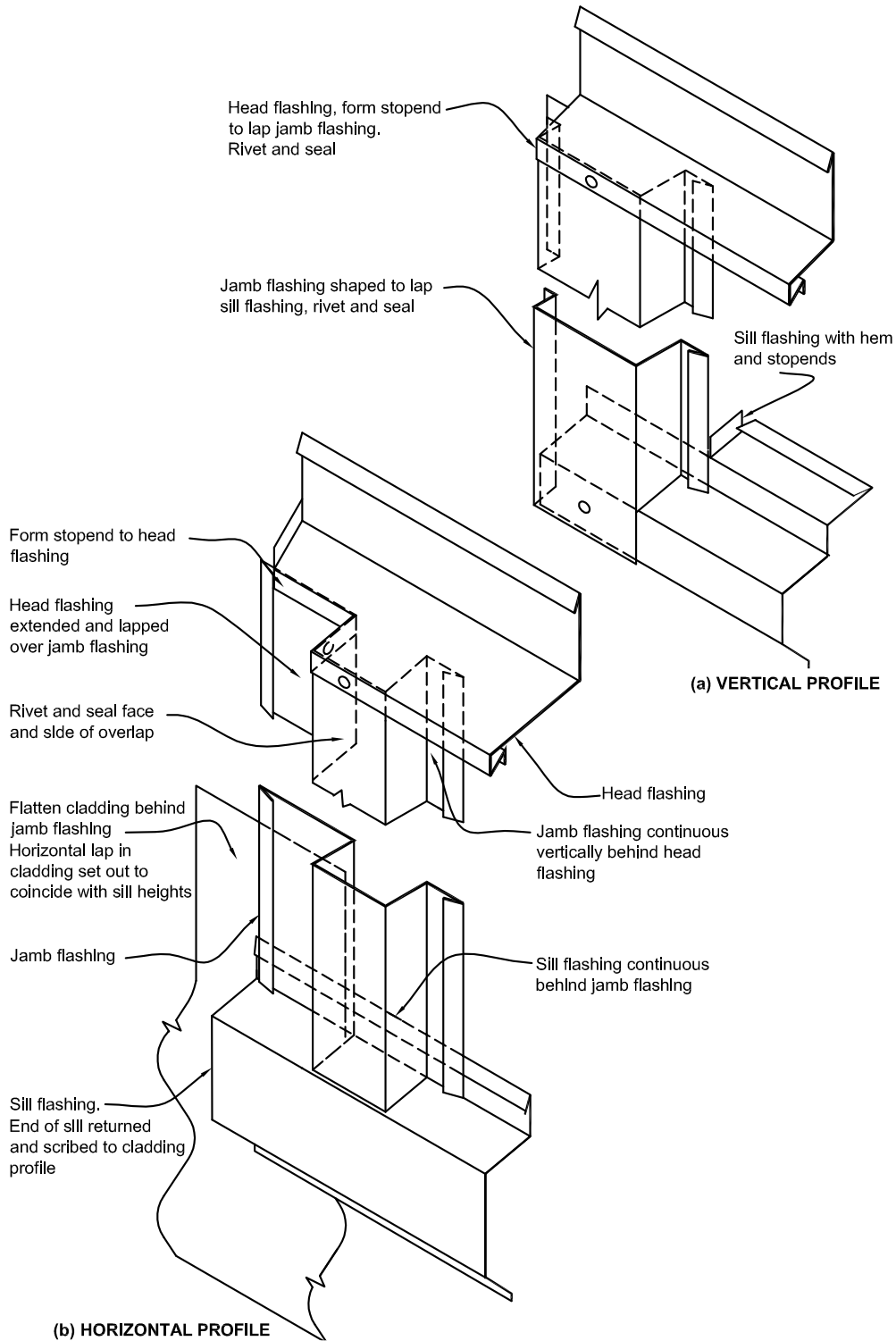

- Notes:** (1) For detail (a), refer to [Figure 9.6.6.8](#) for window.
 (2) For detail (b), refer to [Figure 9.6.7.9A](#) for window.
 (3) *Wall underlay* not shown for clarity.

Wall claddings

Figure 9.6.7.10: Balustrade and parapet for horizontal profiled metal

Paragraph 9.6.7.10

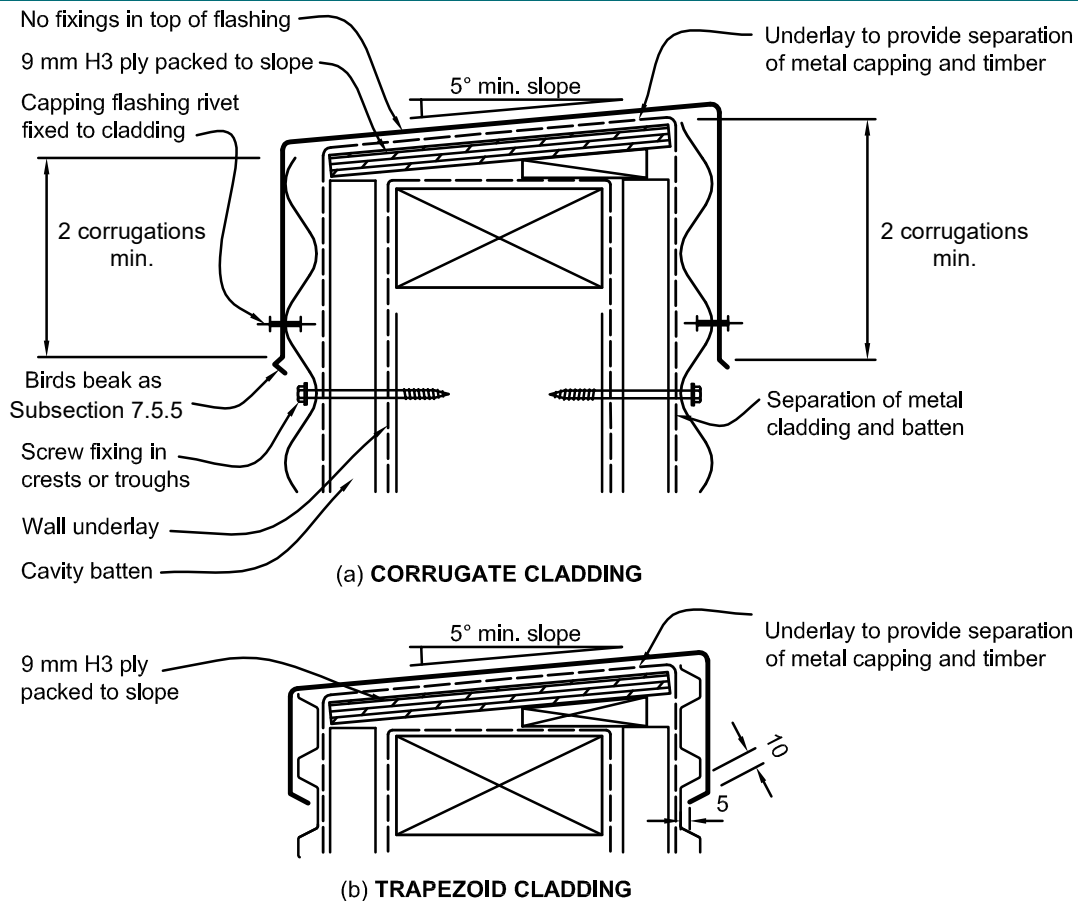

9.7 Fibre cement sheet

9.7.1 Use and limitations

9.7.1.1 This section contains provisions for fibre cement sheet *cladding*.

9.7.1.2 Fibre cement sheet *claddings* shall be either *direct fixed to framing* over a *wall underlay* or fixed over a *drained cavity* based on the *risk score* for the *external wall*, calculated as per Section 3.1 and Table 3.1.2.1.

9.7.1.3 Fibre cement sheet *cladding systems* shall be one of the following types:

- a) *flush-finished* systems over a drained cavity using sheets of 7.5 mm minimum thickness, with:
 - i) fibre cement sheets manufactured with a rebated edge for this purpose, and
 - ii) if necessary for part sheets, rebated on site using a purpose-made tool, and
 - iii) have all edges sealed, and
 - iv) joints, comprising a bedding compound and reinforcing tape, that are finished in accordance with Subsection 9.7.5; or
- b) jointed systems in accordance with Subsection 9.7.4 using sheets of 6 mm minimum thickness with:
 - i) purpose-made jointers, and
 - ii) timber battens over joints.

Wall claddings

9.7.2 Materials

9.7.2.1 Fibre cement shall comply with Subsection 4.2.1 of the Building Product Specifications.

9.7.3 Installation

9.7.3.1 Install sheets with:

- a) paint seals to all sheet edges and cut edges, including 100 mm across back face from each edge; and
- b) a *wall underlay*, as specified in [Table C.2.1.1](#) and Subsections [9.1.4](#), [9.1.5](#), and [9.1.6](#), installed behind fibre cement sheet *claddings*; and
- c) fixings as required in [Table C.3.1.1](#), installed through the *wall underlay* into the *wall framing*; and
- d) all sheet joints located over solid *framing*.

COMMENT: Edge sealing can be improved by application of a second seal coating. It is recommended that the applicator of the *flush-finished* jointing and coating be trained and approved by the supplier of the jointing and finish system.

9.7.4 Jointed systems

9.7.4.1 Jointed systems shall have:

- a) vertical joints with either:
 - i) uPVC jointers (see [Figure 9.7.4.1A](#)), or
 - ii) timber battens (see [Figure 9.7.4.1C](#)); and
- b) internal corners with either:
 - i) uPVC jointers (see [Figure 9.7.4.1B](#)), or
 - ii) timber battens (see [Figure 9.7.4.1B](#)); and
- c) external corners with timber battens (see [Figure 9.7.4.1C](#)); and
- d) horizontal joints with uPVC control joint *flashings* or sheet metal 'Z' *flashings* (see [Figure 9.7.4.1D](#) for *direct fixed* claddings [Figure 9.7.4.1E](#) for cavity fixed systems).

9.7.4.2 *Flashings* shall be either uPVC, aluminium, stainless steel, or copper to Section [4.2](#).

9.7.4.3 Timber battens shall comply with NZS 3602.

9.7.4.4 For jointed systems, all sheet edges shall be sealed prior to fixing. Fibre cement shall be finished with a latex exterior paint system complying with any of Parts 7, 8, 9, or 10 of AS 3730.

Wall claddings

Figure 9.7.4.1A: Vertical uPVC joints for fibre cement sheet

Paragraph 9.7.4.1

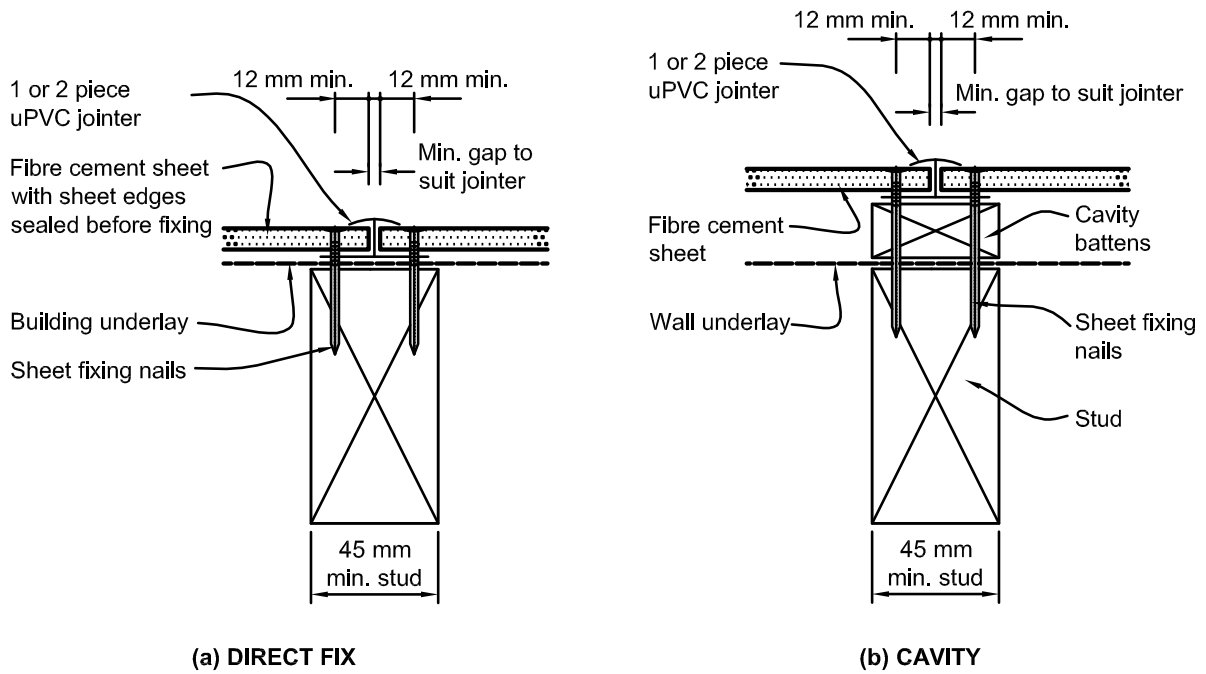

Wall claddings

Figure 9.7.4.1B: Internal corners for fibre cement sheet

Paragraph 9.7.4.1

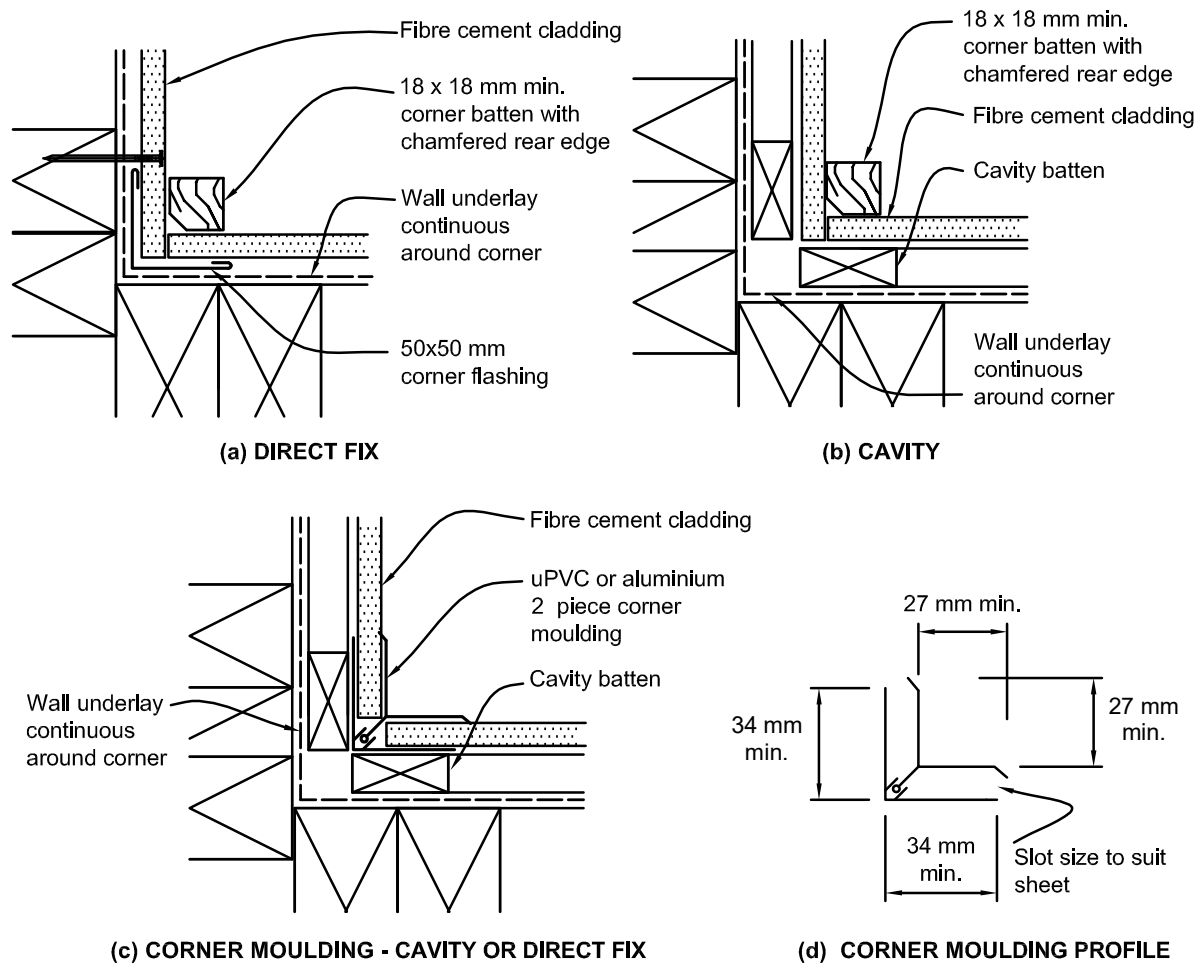

Wall claddings

Figure 9.7.4.1C: Vertical timber batten joints for fibre cement sheet

Paragraph 9.7.4.1

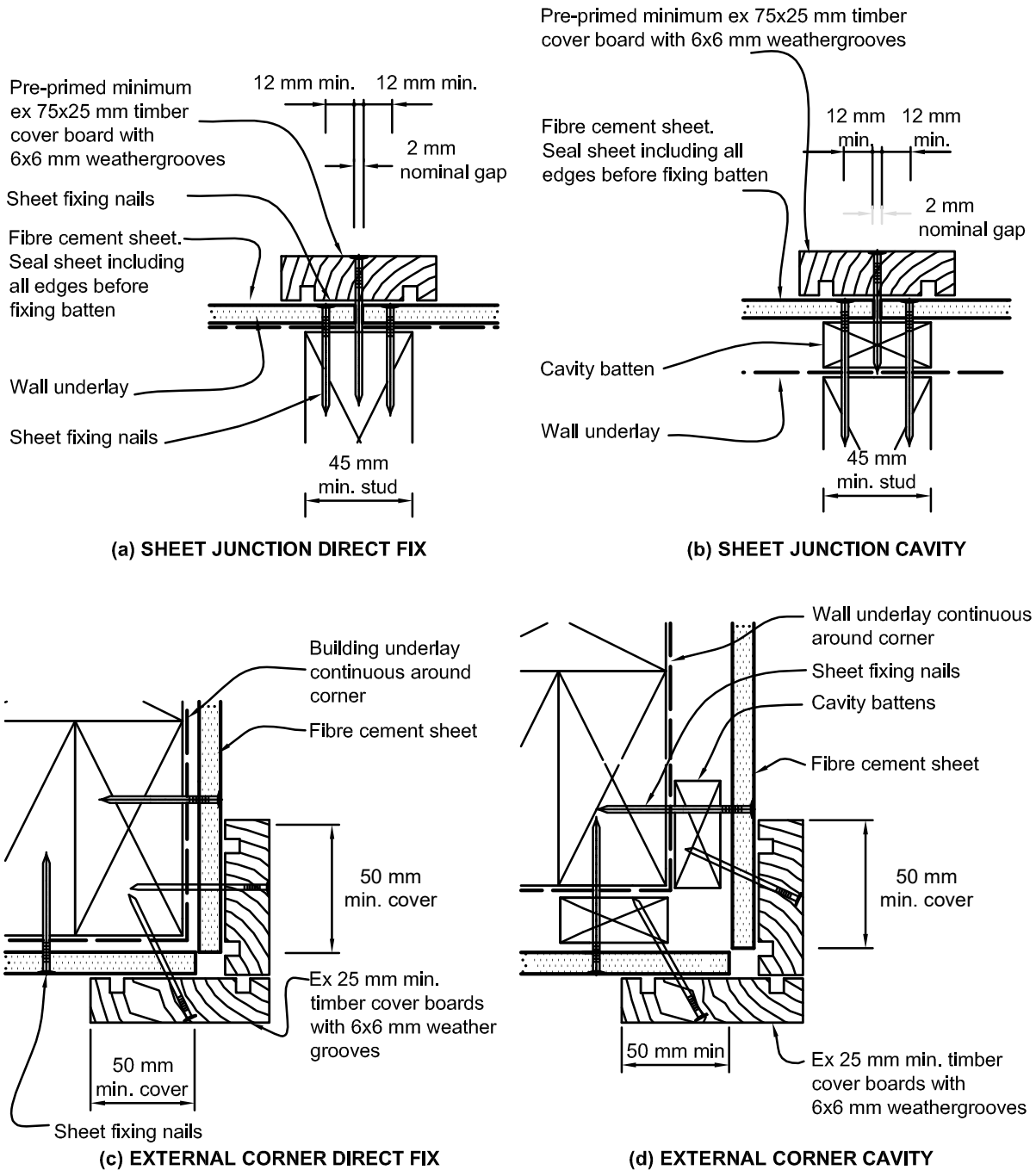

Notes:

- (1) Fibre cement sheet to be sealed including all edges before fixing batten.
- (2) Corner battens shall be sized to provide 50 mm minimum cover over *cladding*.

Wall claddings

Figure 9.7.4.1D: Horizontal joints for direct fixed fibre cement

Paragraph 9.7.4.1

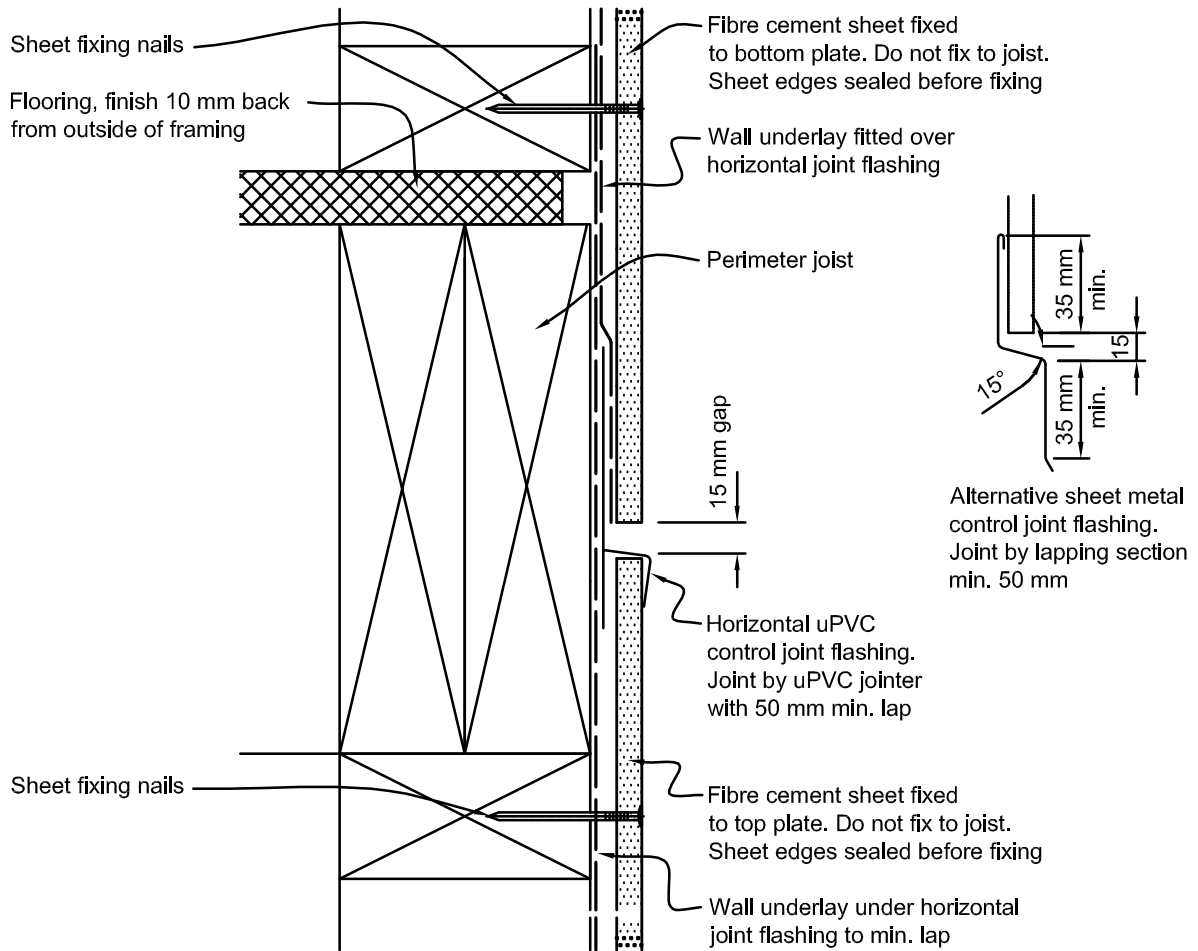

Wall claddings

Figure 9.7.4.1E: Horizontal joints for fibre cement sheet on cavity

Paragraph [9.7.4.1](#)

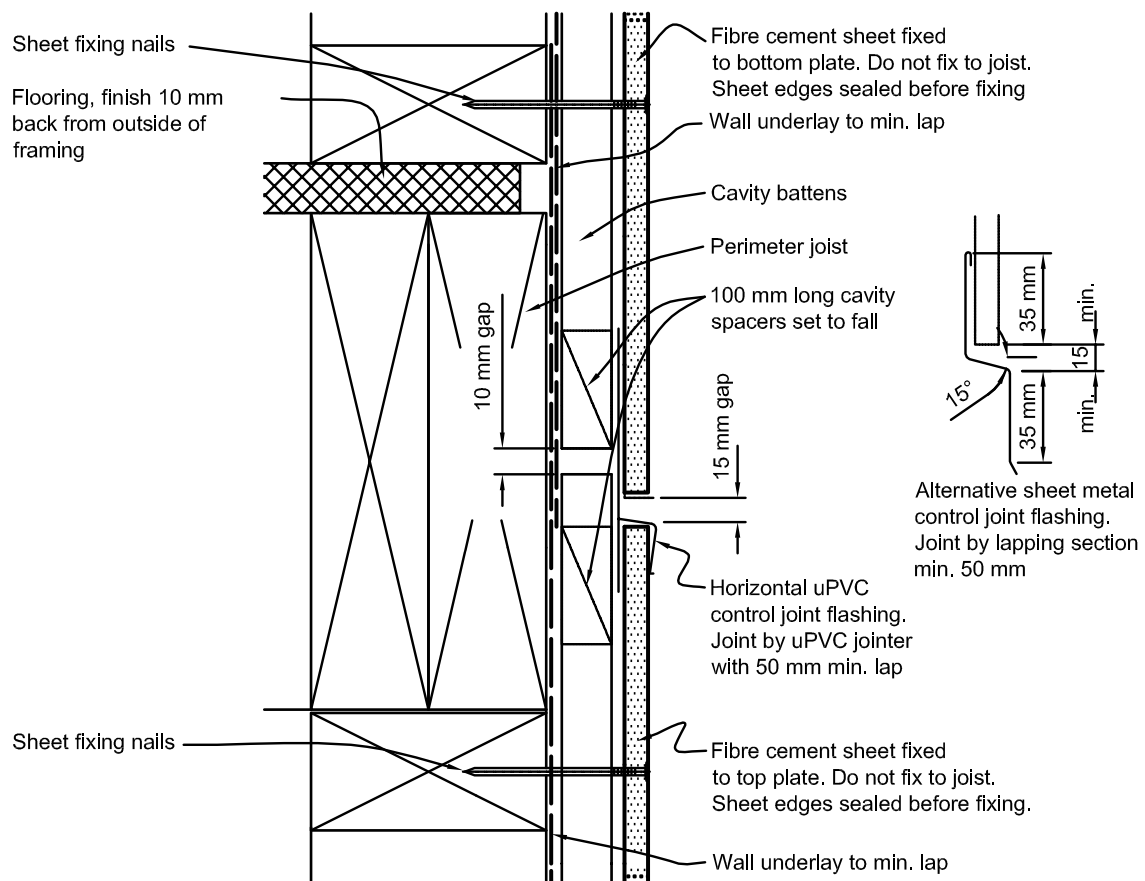

Notes:

- (1) This detail is only suitable for up to 2 storeys or 7 metres in height.
- (2) For cavities in buildings over 2 storeys or 7 metres in height, refer to [Figure 9.1.8.4](#).

9.7.5 Flush-finished systems

9.7.5.1 *Flush-finished* systems shall be constructed over a drained cavity outlined in Subsection [9.1.7](#).

9.7.5.2 *Flush-finished* joints shall be finished with a textured finish system that:

- a) complies with BRANZ EM4, when tested with the specific fibre cement substrate and jointing system used for the *cladding*; and
- b) has all components approved by the supplier of the jointing and finish system; and
- c) where a topcoat of paint over the finish is required to provide weather protection, is a latex exterior paint system complying with any of Parts 7, 8, 9, or 10 of AS 3730.

9.7.5.3 Joints shall be positioned so that they:

- a) do not occur at corners of window or door openings or at changes in the height of a wall; and
- b) are a minimum of 200 mm on either side of the jamb-line of an opening; and
- c) are detailed as shown in [Figure 9.7.5.3](#).

9.7.5.4 External corners shall use uPVC corner reinforcement beneath tape and finishing compound as shown in [Figure 9.7.5.4](#).

Wall claddings

Figure 9.7.5.3: Flush-finished joints for fibre cement sheet

Paragraph 9.7.5.3

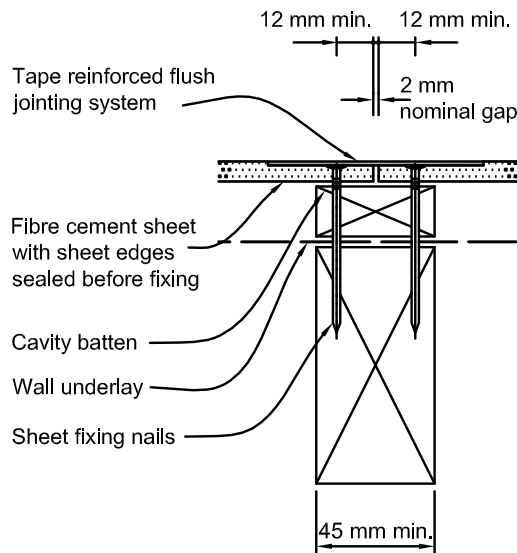

Note: (1) Fibre cement sheet used for this joint must be designed with recessed edge (site produced recesses to compatible sheets are permissible).

Figure 9.7.5.4: Flush-finished external corners for fibre cement sheet

Paragraph 9.7.5.4

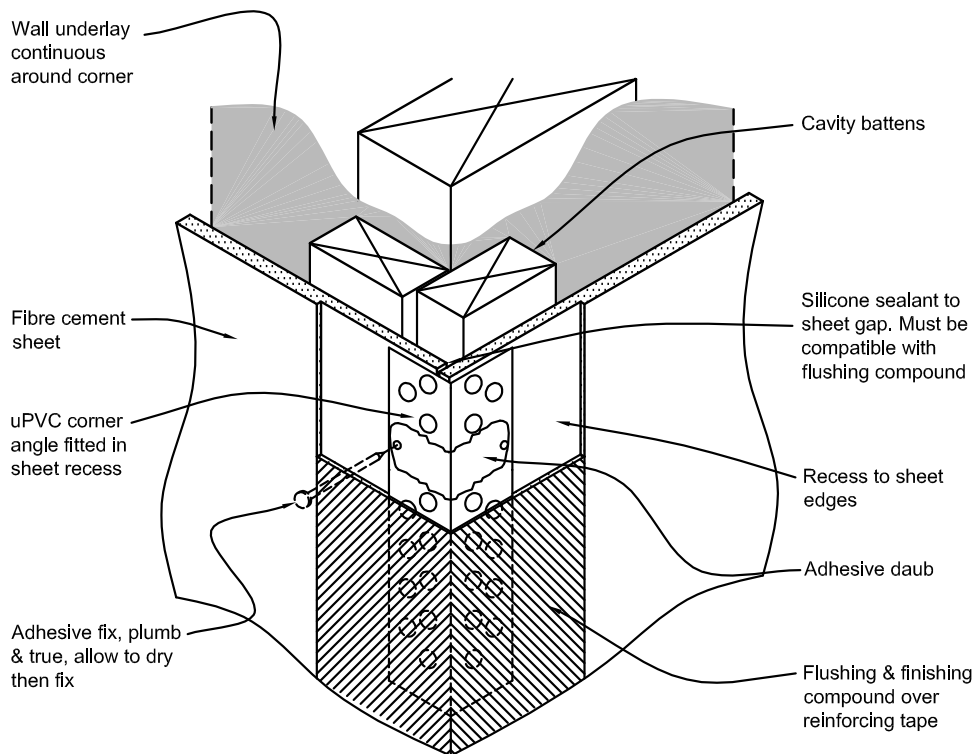

Note: (1) Fibre cement sheet used for this joint must be designed with recessed edge (site produced recesses to compatible sheets are permissible).

Wall claddings

- 9.7.5.5 Internal corners shall use a sealant-filled joint over compressible foam tape as shown in [Figure 9.7.5.6\(b\)](#) with polyethylene bond breaker tape behind joint.
- 9.7.5.6 Vertical control joints shall be located as shown in [Table 9.7.5.6](#), and:
- may occur at the edge of window or door openings; and
 - shall extend the full height of the wall, including where there is a horizontal joint and a vertical control joint on the wall (see [Figure 9.7.5.6](#)); and
 - may be staggered across horizontal control joints.
- 9.7.5.7 Horizontal control joints shall be located as shown in [Table 9.7.5.6](#).
- 9.7.5.8 Finish colour for *flush-finished* systems shall have a reflectance of 40% or more, as outlined in Subsection [2.1.3](#).

Table 9.7.5.6: Control joints for flush-finished fibre cement

Paragraphs [9.7.5.6](#) and [9.7.5.7](#)

Vertical control joints	Horizontal control joints
5400 mm centres max. (6000 mm allowed on <i>walls</i> that finish at an exterior corner)	5400 mm centres max. (on <i>dwangs</i> between full-height, continuous <i>studs</i>)
All internal corners	All floor joist locations

Note: Non-*flush-finished* joints are *control joints*.

Figure 9.7.5.6: Vertical movement control joint for flush-finished fibre cement sheet

Paragraphs [9.7.5.5](#) and [9.7.5.6](#)

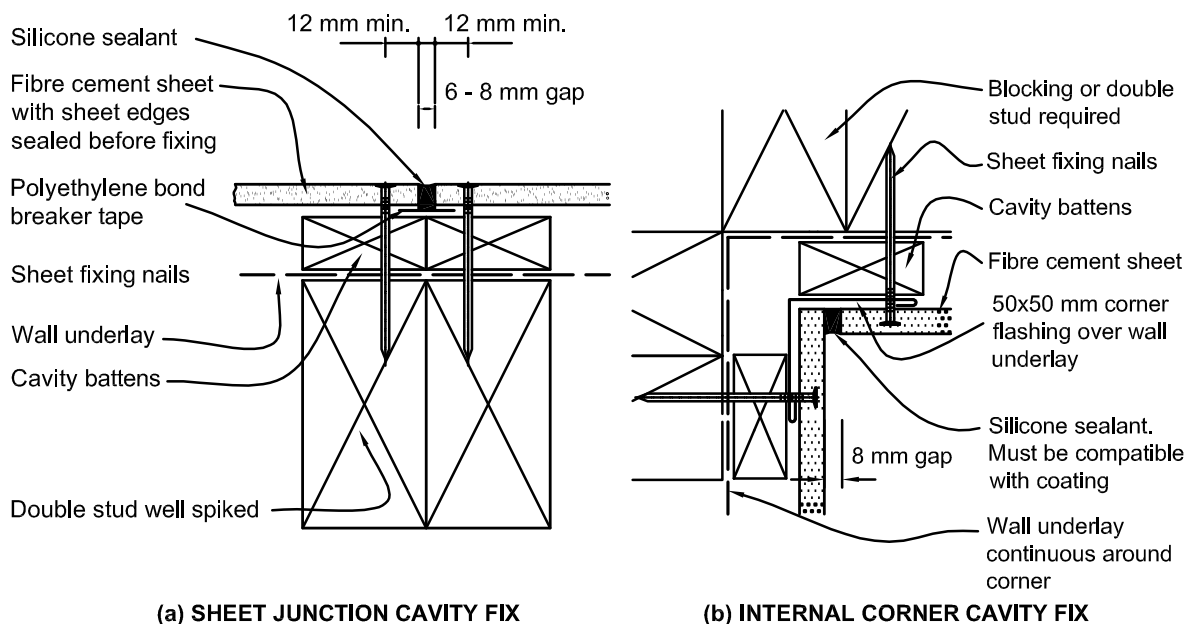

Notes:

- Fibre cement sheet to be sealed including all edges before fixing batten.
- Do not apply paint over sealant. If texture coated, use polyethylene bond breaker tape.

Wall claddings

9.7.6 Soffits

9.7.6.1 Soffits shall be detailed as shown in:

- a) [Figure 9.7.6.1](#) for *flush-finished*; and
- b) [Figure 5.1.4.2](#) for jointed.

Figure 9.7.6.1: Soffit for flush-finished fibre cement sheet

Paragraphs [5.1.4.2](#) and [9.7.6.1](#)

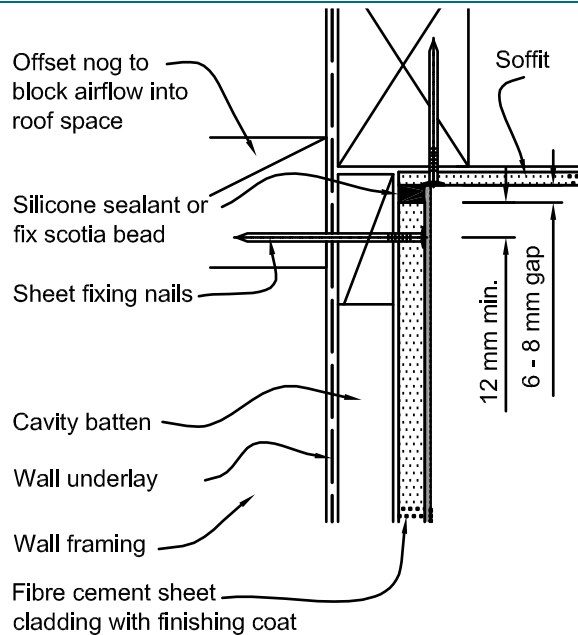

9.7.7 Windows and doors

9.7.7.1 Windows and doors shall be installed in accordance with Subsections [9.1.9](#) and [9.1.10](#) with:

- a) *direct fixed* windows and doors detailed as per [Figure 9.7.7.1A](#); and
- b) windows and doors on cavity detailed as per [Figure 9.7.7.1B](#).

Wall claddings

Figure 9.7.7.1A: Windows and doors for direct fixed fibre cement sheet

Paragraphs 9.7.7.1, 9.8.8.2, and Figure 9.1.10.1

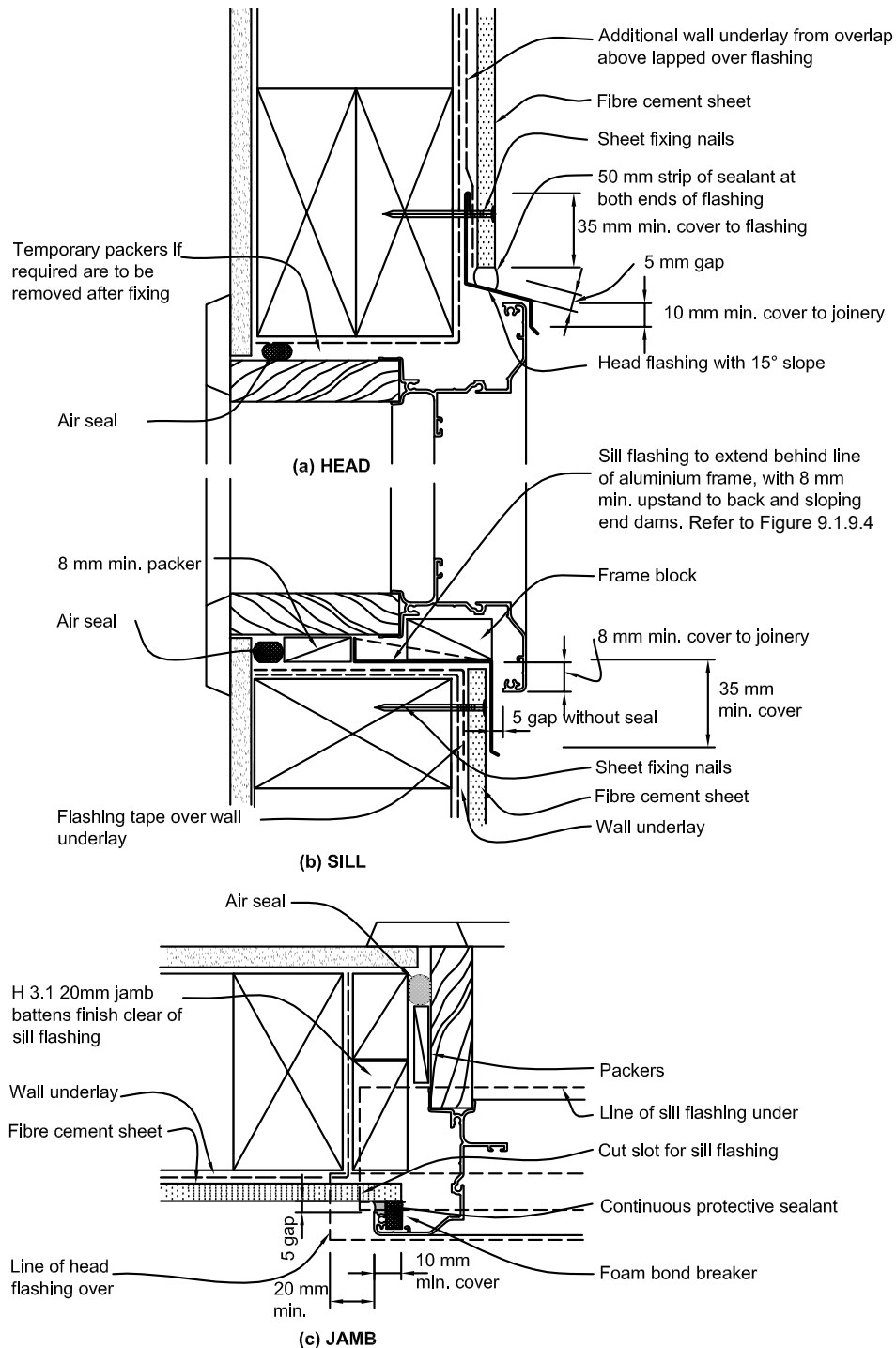
**Notes:**

- (1) Window profile to be selected to achieve the cover shown in the details.
- (2) Architraves are shown for consistency only. The details may be used with rebated liner.
- (3) For wrapping of a framed opening prior to window installation, refer to [Figure 9.1.9.4](#).

Wall claddings

Figure 9.7.7.1B: Windows and doors for fibre cement sheet and flush-finished fibre cement on cavity
 Paragraphs [9.1.9.7](#), [9.7.7.1](#), and [9.8.8.3](#)

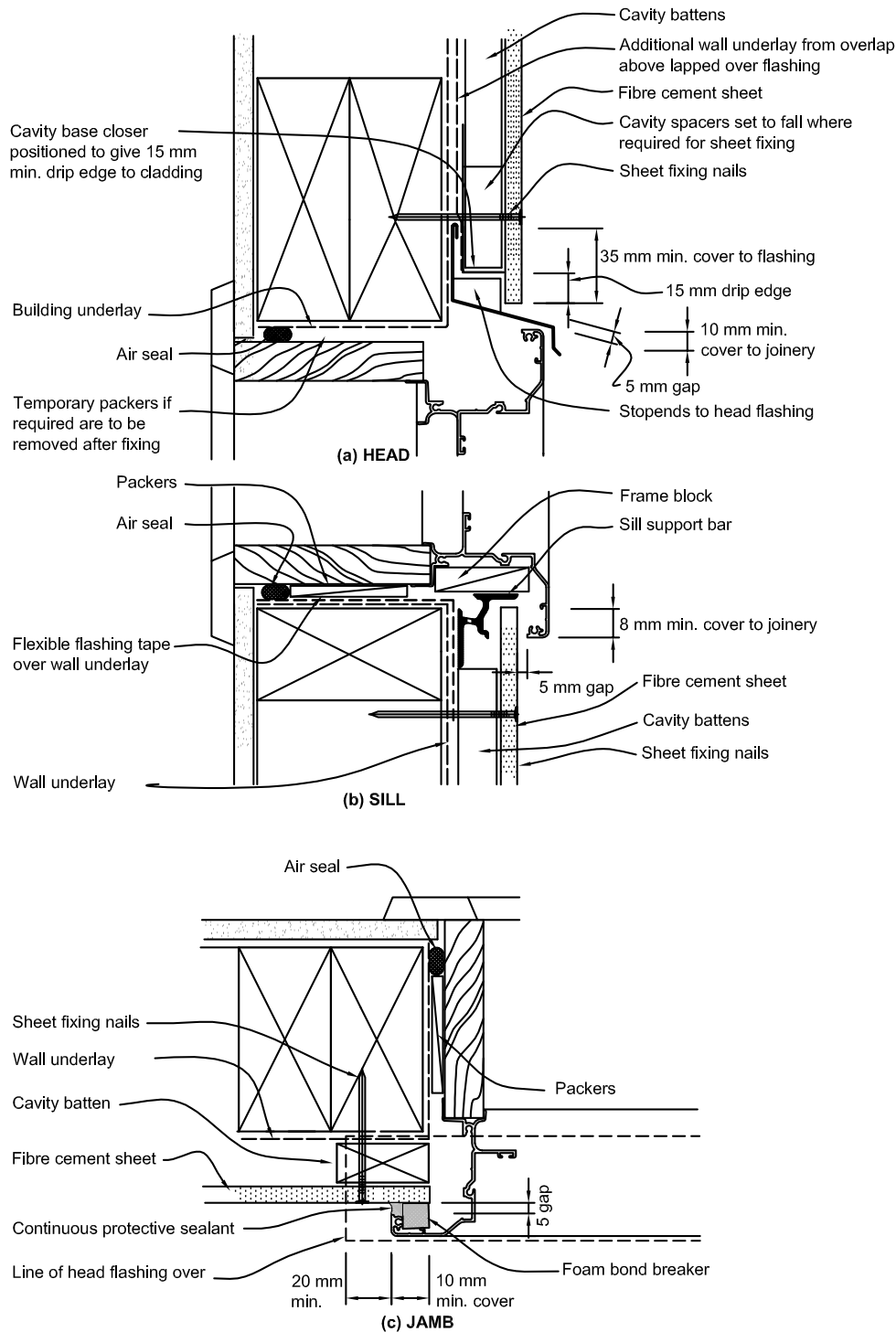

- Notes:** (1) Window profile to be selected to achieve the cover shown in the details.
 (2) Architraves are shown for consistency only. The details may be used with rebated liner.
 (3) A sill support bar conforming to EM6 and Paragraph [9.1.10.4](#) is required. Refer to [Figure 9.1.9.6](#).
 (4) For sealant at head for Very High and Extra High wind zones, refer to [Figure 9.1.10.1\(c\)](#).

Wall claddings

9.7.8 Parapets and enclosed balustrades

9.7.8.1 *Parapets* shall comply with [Part 6. Parapets](#).

9.7.8.2 *Enclosed balustrades* shall comply with Section [7.5](#).

9.7.8.3 Balustrade *cappings* shall be:

- a) metal, butyl *membrane*, or EPDM *membrane* to Subsection [6.2.1](#); or
- b) *flush-finished* fibre cement to Paragraph [9.7.8.4](#) and [Figure 9.7.8.4](#).

9.7.8.4 Where the tops to *enclosed balustrades* are formed using *flush-finished* fibre cement, they shall have a minimum fall of 10° (1:6), and be wrapped as shown in [Figure 9.7.8.4](#), with a *waterproofing membrane*, approved by the supplier of the jointing and finish system. The *membrane* shall be fully protected by the coating and shall comply with the requirements of AS/NZS 4858 Table 8, Parts (a) to (e), except that bleach and detergent immersion set out in Appendix A1 shall not be required.

Figure 9.7.8.4: Enclosed balustrade to wall for fibre cement sheet

Paragraphs [9.7.8.3](#), [9.7.8.4](#), and [Table 4.5.1.1](#)

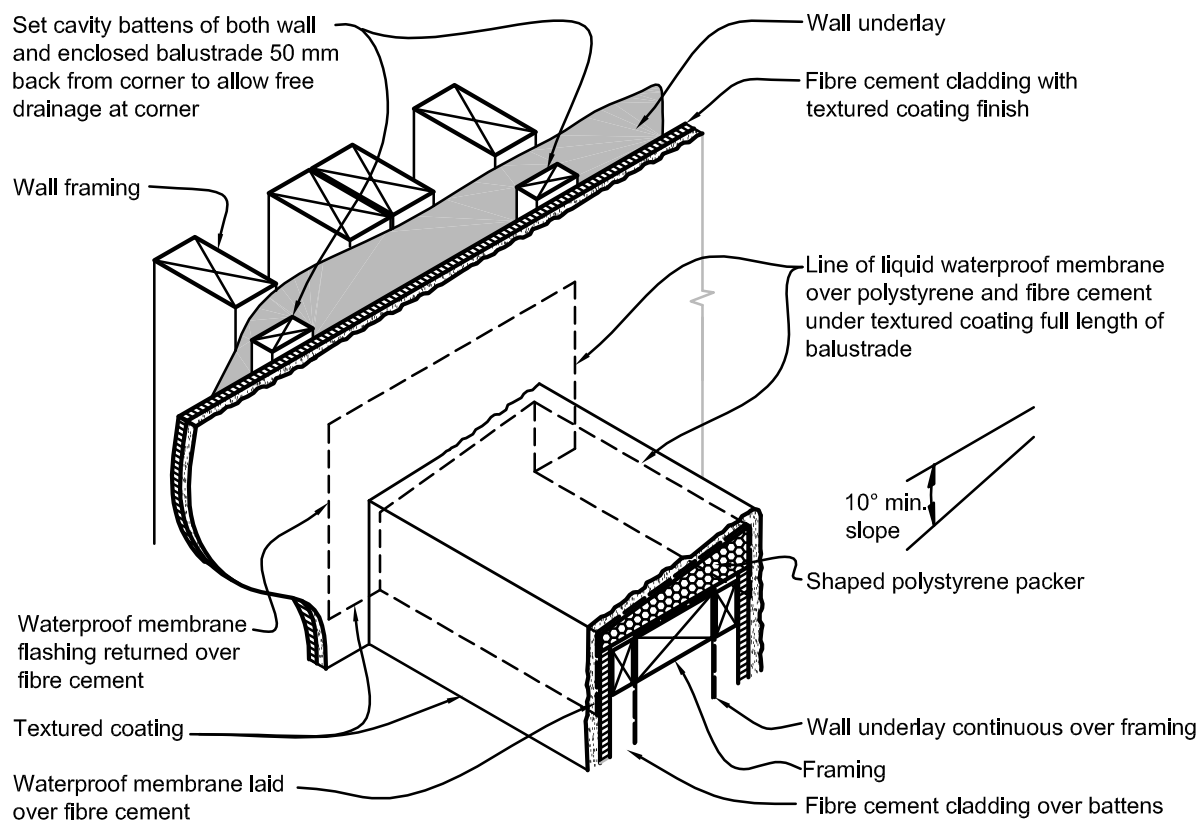

Notes:

- (1) For details of framing and bridge over cavity, refer to [Figure 6.2.3.1A](#) and [Figure 6.2.3.1B](#).
- (2) Flush finish fibre cement balustrades only permitted with *cavity construction*. Refer to Subsection [9.1.7](#).

Wall claddings

9.7.9 Decorative attachments

- 9.7.9.1 Where decorative attachments are used, seal sheets prior to attachment of the decorative elements. The final weatherproofing system shall be applied over decorative elements and *wall cladding*. Horizontal decorative elements shall have top surfaces sloped to a minimum of 10° and drip mouldings to bottom edges.
- 9.7.9.2 Attachments shall not interfere with the functioning of critical joints such as *control joints*.

COMMENT: Alternatively, a decorative moulding may be formed from the coating by using mesh and plaster.

9.8 Plywood sheet

9.8.1 Use and limitations

- 9.8.1.1 This section contains provisions for plywood sheet *claddings*.
- 9.8.1.2 Plywood sheet *claddings* shall have vertical battened joints and flashed horizontal joints between plywood panels.
- 9.8.1.3 Plywood-sheet *claddings* shall be either *direct fixed* to *framing* over a *wall underlay* or fixed over a *drained cavity* as per Subsection [9.1.7](#).
- 9.8.1.4 Based on the *risk score* for the *external wall*, calculated as per Section [3.1](#), the sheet *cladding* may require the inclusion of a *drained cavity*.

9.8.2 Materials

- 9.8.2.1 Batten-jointed panels shall have weather-grooved timber battens as shown in [Figure 9.8.2.1](#).
- 9.8.2.2 Plywood panels shall be:
- manufactured to AS/NZS 2269, grade CD; and
 - a minimum of 5 ply; and
 - a minimum of 12 mm in thickness; and
 - treated as required by NZS 3602.

Figure 9.8.2.1: Battened joints for plywood sheet

Paragraph [9.8.2.1](#) and [9.8.3.3](#)

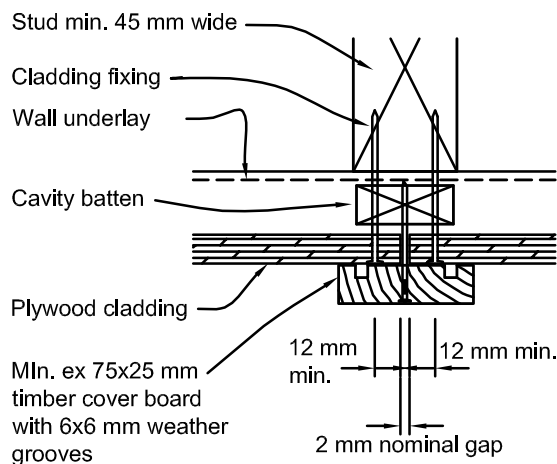

Note: (1) *Direct fixed* is similar.

Wall claddings

9.8.3 Installation

- 9.8.3.1 A wall underlay, as specified in [Table C.2.1.1](#), shall be installed behind plywood sheet claddings.
- 9.8.3.2 Plywood sheets shall be fixed through the wall underlay into the wall framing with fixings as required in [Table C.3.1.1](#).
- 9.8.3.3 All joints shall:
- be made only over supports; and
 - if horizontal, incorporate a 10 mm expansion gap, and be fitted with a flashing, as shown in [Figure 9.8.3.3](#); or
 - if vertical, have battened joints (see [Figure 9.8.2.1](#)).

Figure 9.8.3.3: Horizontal joints for plywood sheet

Paragraph [9.8.3.3](#)

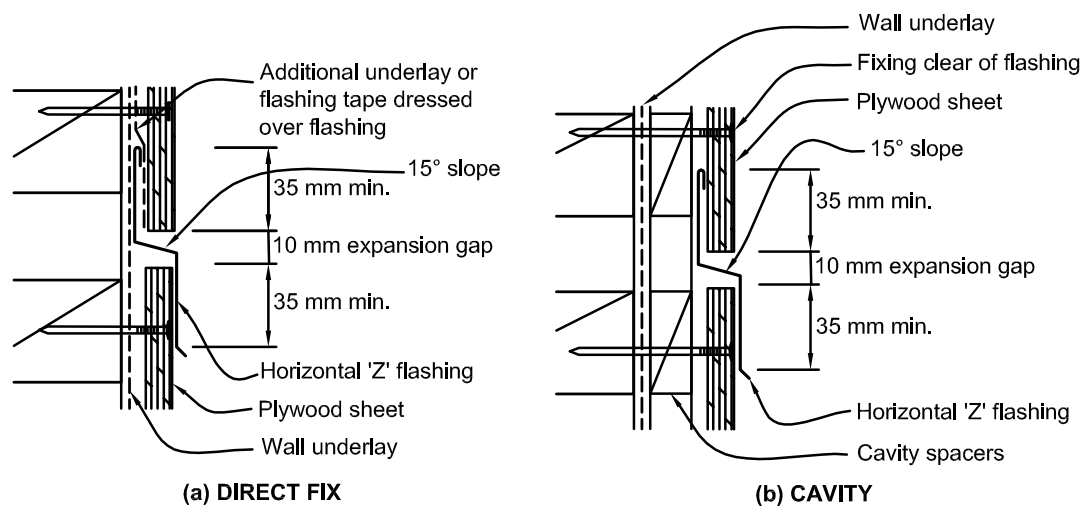

Notes:

- This detail is only suitable for up to 2 storeys or 7 metres in height.
- For cavities in buildings over 2 storeys or 7 metres in height, refer to [Figure 9.1.8.4](#).

9.8.4 Corners

- 9.8.4.1 External corners shall be fitted with timber battens, as shown in [Figure 9.8.4.1](#).
- 9.8.4.2 Internal corners shall be as shown in [Figure 9.8.4.2](#) and have:
- flashings and timber battens for *direct fixed* systems; and
 - timber battens for cavity systems.

Wall claddings

Figure 9.8.4.1: External corners for plywood sheet

Paragraph [9.8.4.1](#)

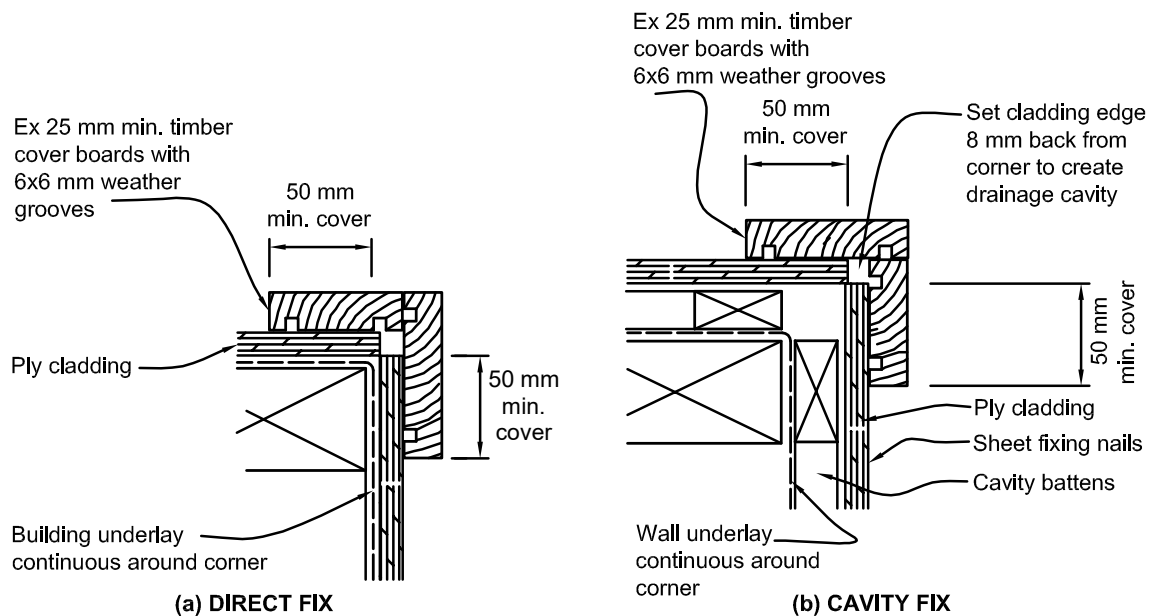

Note: (1) Corner battens shall be sized to provide 50 mm minimum cover over *cladding*.

Figure 9.8.4.2: Internal corners for plywood sheet

Paragraph [9.8.4.2](#)

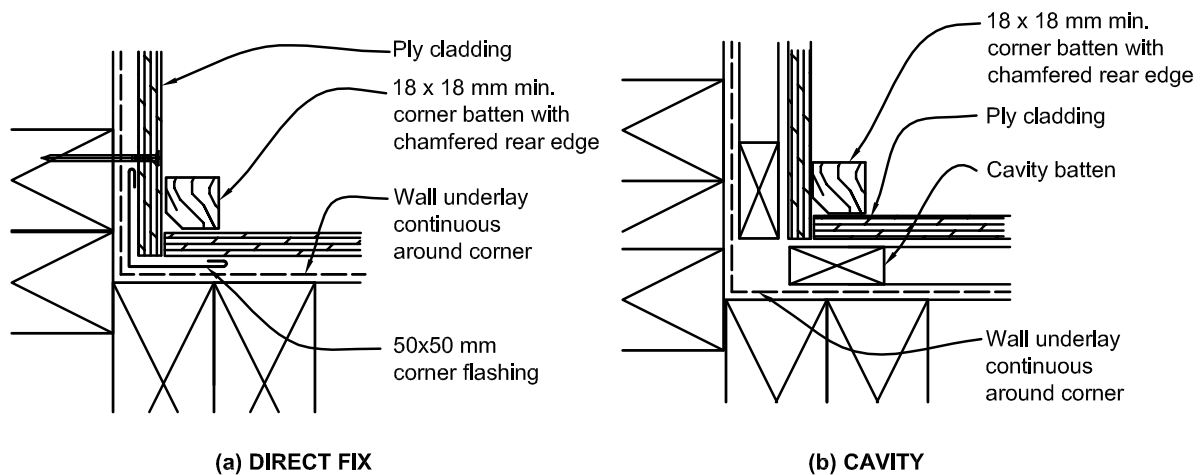

9.8.5 Flashings

9.8.5.1 Flashings shall be metal selected in accordance with [Table C.1.1.1A](#), [Table C.1.1.1B](#), [Table C.1.1.1C](#), and [Section 4.2](#).

9.8.6 Soffits

9.8.6.1 Soffits shall be as shown in [Figure 5.1.4.2](#) and Subsection [5.1.4](#).

9.8.7 Parapets and enclosed balustrades

9.8.7.1 *Parapets and enclosed balustrades* shall be capped with metal, butyl membrane, or EPDM membrane.

Wall claddings

9.8.7.2 *Cappings* shall comply with the requirements of [Part 4. Flashings](#).

9.8.7.3 *Parapets* shall be in accordance with [Part 6. Parapets](#).

9.8.7.4 *Enclosed balustrades* shall be in accordance with Section [7.5](#).

9.8.8 Windows and doors

9.8.8.1 Windows and doors shall be installed in accordance with Subsections [9.1.9](#) and [9.1.10](#).

9.8.8.2 For *direct fixed* systems, windows and doors shall be detailed as shown for fibre cement sheet cladding (see [Figure 9.7.7.1A](#)).

9.8.8.3 For cavity systems, windows and doors shall be detailed as shown for fibre cement sheet cladding (see [Figure 9.7.7.1B](#)).

COMMENT: The same principles of window installation apply to both fibre cement and plywood sheet cladding.

9.8.9 Finishes

9.8.9.1 A solution of 12.5% copper naphthenate in white spirits, or mineral turpentine, shall be brushed on to any edges cut after treatment.

9.8.9.2 *Direct fixed* plywood cladding used as bracing requires a minimum 50-year durability, and shall be treated to H3, painted on all edges and the outer face with a latex exterior paint system complying with any of Parts 7, 8, 9, or 10 of AS 3730.

COMMENT: Plywood for cladding, treated to H3, does not usually require painting. While H3 plywood can be left unpainted, it is likely to develop checking and mould growth on the surface. Plywood used as bracing requires painting and regular maintenance of the paint finish to ensure the 50-year durability is achieved.

9.9 EIFS

9.9.1 Use and limitations

9.9.1.1 This section contains provisions Exterior Insulation and Finish Systems (EIFS).

9.9.1.2 *EIFS cladding systems* shall:

- a) utilise either polymer-modified cement-based plaster or polymer-based polystyrene-based plaster; and
- b) be designed and tested as a total system; and
- c) not be fixed:
 - i) so as to form a horizontal surface, or
 - ii) as a replacement for roofing, or
 - iii) in such a way as to allow water to pond.

9.9.1.3 *EIFS cladding* shall be fixed over a *drained cavity* as described in Subsection [9.1.7](#).

9.9.2 Materials

9.9.2.1 *EIFS cladding systems* shall comprise the following parts:

- a) a polystyrene sheet cladding material; and
- b) a polymer-modified cement-based plaster or a polymer-based plaster, reinforced with fibreglass mesh; and

Wall claddings

- c) a polymer-modified cement or polymer-based finishing plaster, and a latex exterior paint system complying with any of Parts 7, 8, 9, or 10 of AS 3730; and
- d) a range of head, sill, jamb, corner and base mouldings suitable for exterior use; and
- e) a flexible polymeric neutral cure sealant that:
 - i) is approved by the *cladding system* supplier, and
 - ii) complies with either Type F, Class 20LM, or 25LM of ISO 11600; or with low modulus Type II Class A of Federal Specification TT-S-00230C.

COMMENT: This is the minimum standard, and extra elements deemed suitable by the system supplier should not be excluded on the basis of this acceptable solution.

- 9.9.2.2 Polystyrene sheet shall be a minimum of 40 mm thick and shall be either:
 - a) expanded polystyrene (EPS) complying with AS 1366: Part 3, Class H or Class S; or
 - b) extruded polystyrene (XPS) that complies with AS 1366: Part 4.
- 9.9.2.3 Fibreglass reinforcing mesh shall be alkali-resistant fibreglass mesh that complies with Subsection 4.2.2 of the Building Product Specifications.

9.9.3 Installation

- 9.9.3.1 A *wall underlay*, as specified in [Table C.2.1.1](#) and Subsections [9.1.4](#), [9.1.5](#), and [9.1.6](#), shall be fixed to the *framing*.
- 9.9.3.2 Polystyrene sheets shall be fixed through the *cavity battens*, and *wall underlay* into the *wall framing* with fixings as required in [Table C.3.1.1](#). Fixings shall:
 - a) be spaced as shown in [Table C.3.1.1](#); and
 - b) penetrate the *framing* by 30 mm minimum; and
 - c) comply with AS/NZS 4680; and
 - d) be either:
 - i) hot-dipped galvanized springhead nails with a 22 mm top, or
 - ii) hot-dipped galvanized flat head nails used in conjunction with a 22 mm minimum diameter plastic washer.
- 9.9.3.3 Joints to plain-edged sheets shall be butt jointed over solid timber backing. Rebated or tongued boards may be jointed away from solid timber backing, providing the joint is self-supporting at both edges. Corner joints shall be butted together and fully supported along the length of the joint.
- 9.9.3.4 *Control joints* shall always be located over solid timber backing and shall be as shown in [Figure 9.9.3.4](#), and shall be provided:
 - a) on all walls over 20 metres long or over 7 metres high including gables; and
 - b) at abutments to different *cladding* types; and
 - c) where *cladding* covers different structural materials such as timber to concrete; and
 - d) over a movement *control joint* in the underlying *framing*.

COMMENT: The system supplier may require *control joints* at closer spacings than those specified in Paragraph 9.9.3.4(a).

- 9.9.3.5 H3.2 treated timber fixing blocks shall be provided at appropriate locations for fixing all downpipe brackets, garden taps, and other outside fittings. The blocks shall be cut to suit the polystyrene thickness, and fixed to *framing* or *cavity battens*. Prior to applying the plaster basecoat, a patch shall be applied that:

Wall claddings

- a) extends over the timber block face and overlaps the adjacent polystyrene by a minimum of 50 mm; and
- b) is suitable for the direct application of the base coat, and is either:
 - i) a butyl-based *flexible flashing tape* that complies with Parts 3.2 and 4 of ICBO Acceptance Criteria AC148, or
 - ii) a *waterproofing membrane* that complies with the requirements of AS/NZS 4858 Table 8, Parts (a) to (e), except that bleach and detergent immersion set out in Appendix A1 shall not be required.

9.9.3.6 The design of fixing blocks for connecting items carrying substantial loads such as stringers for decks are outside the scope of this acceptable solution and will require *specific design*.

Figure 9.9.3.4: Control joints for EIFS

Paragraph 9.9.3.4

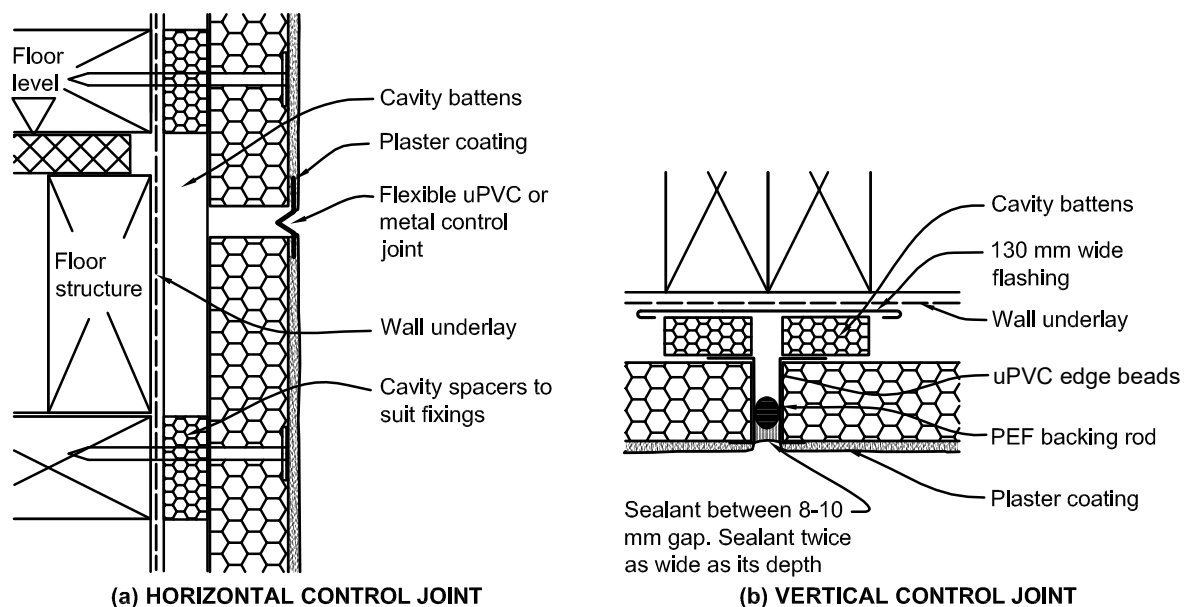

Notes:

- (1) This detail is only suitable for up to 2 storeys or 7 metres in height.
- (2) For cavities in buildings over 2 storeys or 7 metres in height, refer to [Figure 9.1.8.4](#).

9.9.4 Battens

9.9.4.1 *Cavity battens* shall comply with Paragraph [9.1.7.8](#) and [9.1.7.9](#) and installed as in Subsection [9.1.7](#).

COMMENT: *Cavity spacers* must be short and sloped to prevent water being trapped by the battens and ventilation being restricted.

9.9.5 Coating

- 9.9.5.1 *EIFS cladding systems* and their coatings shall be tested for their tensile-adhesion performance in accordance with Paragraph 4.2.2.4 of the Building Product Specifications.
- 9.9.5.2 The entire surface of the polystyrene sheet (including corners) must be continuously reinforced with alkali-resistant fibreglass reinforcing mesh as specified in Paragraph [9.9.2.3](#).

Wall claddings

- 9.9.5.3 The reinforcing base coat shall have:
- a base coat plaster at the greater of the system supplier's minimum recommended thickness or 3 mm thick, and be either:
 - polymer-modified cement-based,
 - polymer-based; and
 - reinforcing with an alkali-resistant fibreglass mesh (Paragraph [9.9.2.3](#)); and
 - cover to mesh of at least 1.5 mm plaster.
- 9.9.5.4 Finish colour shall have a reflectance of 40% or more, as outlined in Subsection [2.1.3](#). The finish shall comprise either:
- one or more coats of polymer-modified cement-based plaster or polymer-based plaster; or
 - one or more coats of a pre-coloured polymer-modified cement-based plaster; or
 - a pre-coloured polymer-based plaster applied according to the conditions specified by the plaster manufacturer.
- 9.9.5.5 Where necessary to maintain *weathertightness*, *EIFS* shall be finished with a latex exterior paint system complying with any of Parts 7, 8, 9, or 10 of AS 3730.
- 9.9.5.6 Polymer-modified cement-based plaster shall only be applied out of direct sunlight and when the temperature is between 5°C and 30°C, with the expectation that the temperature will be in that range for the following 24 hours.
- 9.9.5.7 Decorative mouldings shall be formed from polystyrene, and shall be glued or mechanically fastened to ensure they remain securely attached to *EIFS cladding or framing*.
- 9.9.5.8 Where decorative mouldings are attached, the basecoat shall be applied before the moulding.

COMMENT: Alternatively, a decorative moulding may be formed from the coating by using mesh and plaster.

9.9.6 EIFS/floor slab junctions

- 9.9.6.1 The bottom of the *EIFS cladding* shall be as shown in [Figure 9.9.6.1](#).

Figure 9.9.6.1: Bottom of cladding for EIFS

Paragraph [9.9.6.1](#)

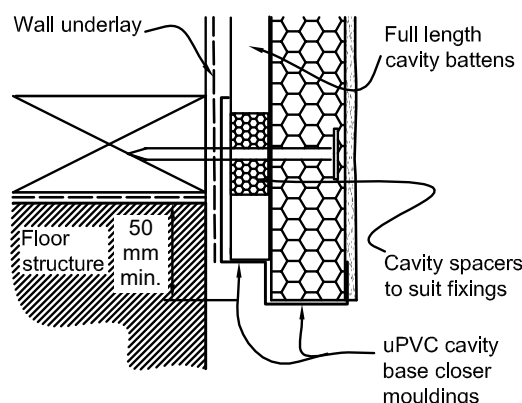

Notes:

- A 6 mm offset of *framing* to the foundation is not necessary where *drained cavities* are used.
- Refer to Subsection [9.1.2](#) for ground clearances.

Wall claddings

9.9.7 Pipes and service penetrations

9.9.7.1 All pipes and service penetrations through the *EIFS* shall be made weatherproof, by either:

- a) a sleeve or conduit penetrating the *EIFS* and sealed into the *EIFS* system as shown in [Figure 9.9.7.1](#); or
- b) a face-fitted flange at *EIFS* surface, sealed with a neutral cure sealant complying with:
 - i) Type F, Class 20LM, or 25LM of ISO 11600, or
 - ii) low modulus Type II Class A of Federal Specification TT-S-00230C.

9.9.7.2 Pipe penetrations shall be installed to slope downwards to exterior. Refer to [Figure 9.1.8.3A](#).

9.9.7.3 Where cables penetrate *cladding*, a sleeve or conduit shall be provided and sealed into the *EIFS* system. All wires that pass through a conduit shall be sealed into position inside the conduit.

Figure 9.9.7.1: Penetration for EIFS

Paragraph [9.9.7.1](#)

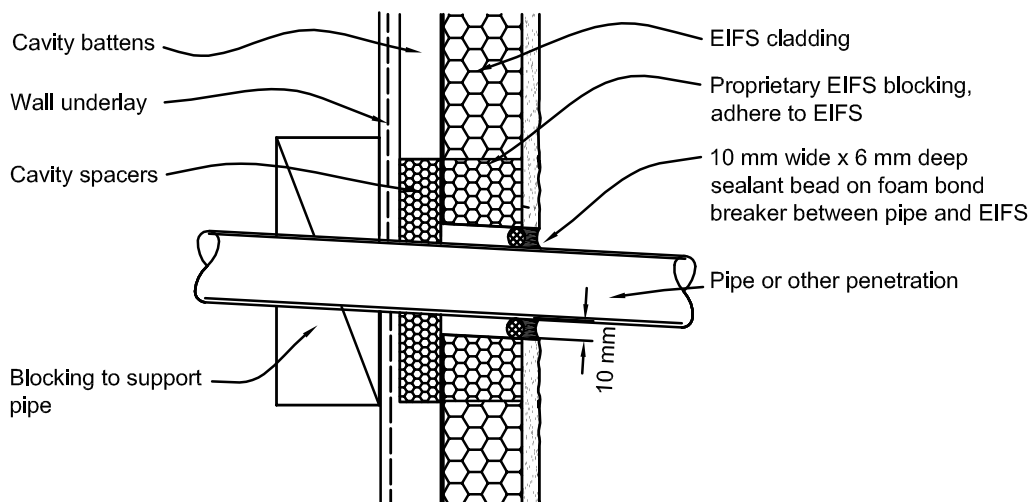

Note: (1) For pipe sealing to the *wall underlay*, refer to [Figure 9.1.8.3A](#).

9.9.8 Windows and doors

9.9.8.1 Windows and doors shall be installed in accordance with Subsection [9.1.9](#) and [9.1.10](#), and shown in [Figure 9.1.10.4](#), [Figure 9.9.8.1A](#), and [Figure 9.9.8.1B](#).

9.9.8.2 Install uPVC three-way corner *flashings* at jamb/sill junctions as shown in [Figure 9.9.8.1A](#). Corner *flashings* shall be installed behind *EIFS* jamb and sill *flashings*, with flanges turned out over polystyrene backing sheets.

9.9.9 Parapets and enclosed balustrades

9.9.9.1 Parapets shall comply with [Part 6. Parapets](#).

9.9.9.2 Enclosed balustrades shall comply with Section [7.5](#).

9.9.9.3 Where the tops to enclosed balustrades are formed using *EIFS*, they shall have a minimum fall of 10° (1:6), and be wrapped as shown in [Figure 9.9.9.3](#) and [Figure 9.9.9.4](#), with a liquid waterproofing *membrane* approved by the supplier. The *membrane* shall be fully protected by the coating, and shall comply with the requirements of AS/NZS 4858 Table 8, Parts (a) to (e), except that bleach and detergent immersion set out in Appendix A1 shall not be required.

9.9.9.4 Metal *cappings* shall comply with the requirements of Subsection [6.2.2](#), and shall be as shown in [Figure 9.9.9.4](#).

Wall claddings

9.9.9.5 Where a parapet or an enclosed balustrade meets *EIFS wall cladding*, a *saddle flashing* shall be used, as shown in [Figure 6.2.3.1A](#) and [Figure 6.2.3.1B](#).

Figure 9.9.8.1A: Window and door corner flashing for EIFS

Paragraph [9.9.8.1](#)

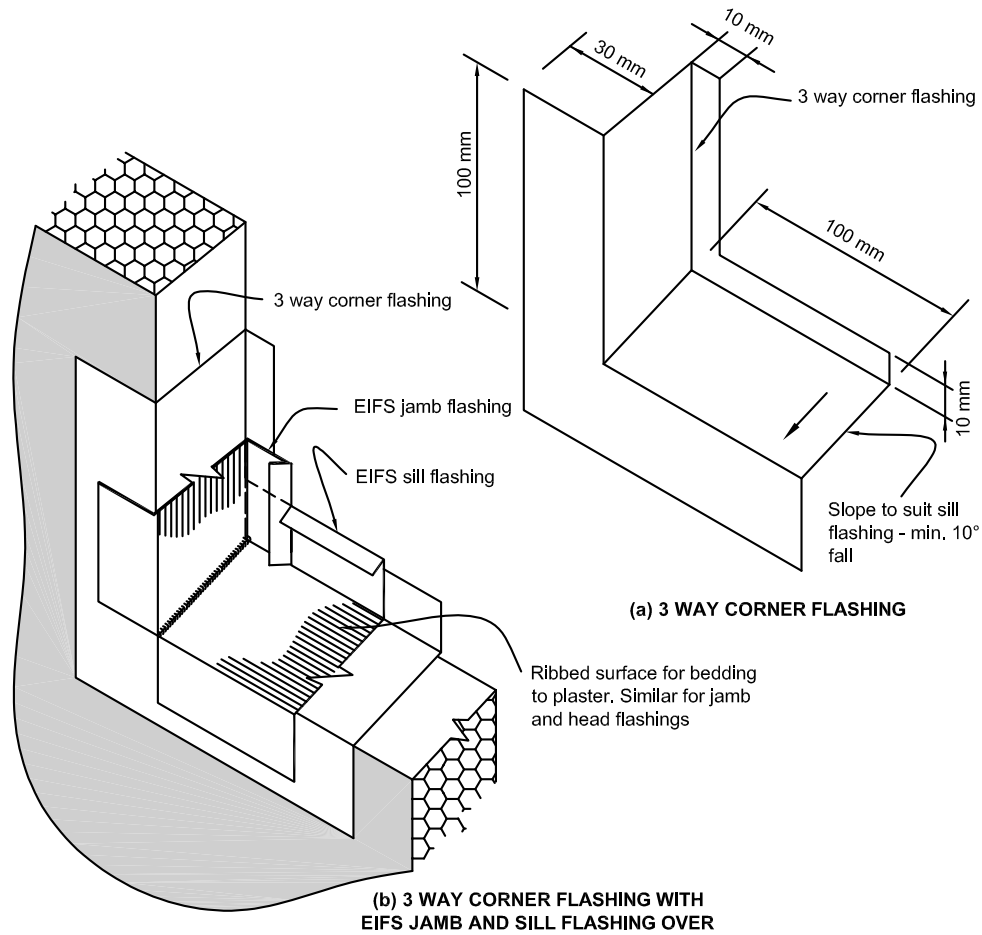

Wall claddings

Figure 9.9.8.1B: Windows and doors in EIFS

Paragraph 9.9.8.1

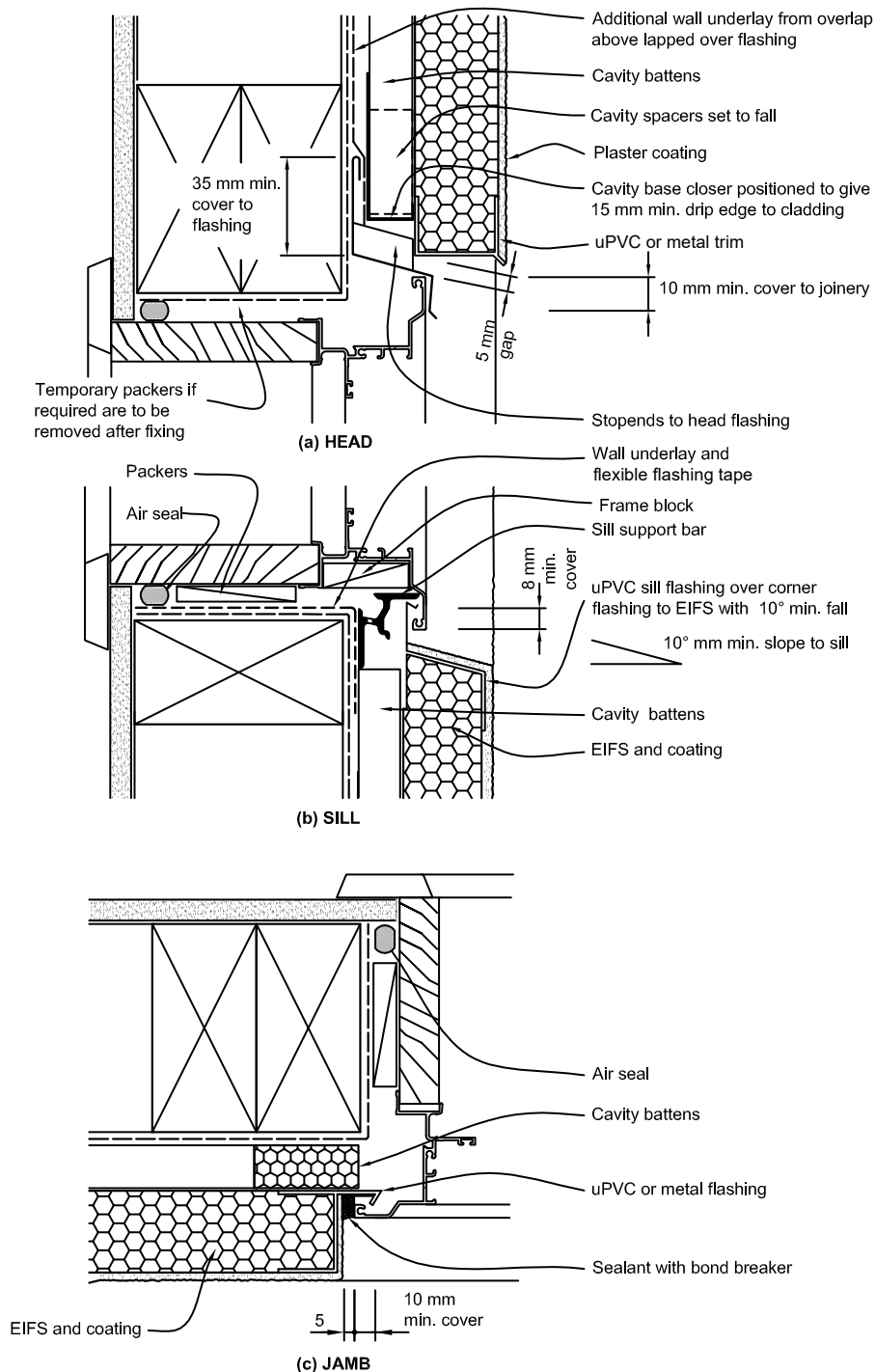

- Notes:**
- (1) Window profile to be selected to achieve the cover shown in the details.
 - (2) Architraves are shown for consistency only. The details may be used with rebated liner.
 - (3) A sill support bar conforming to EM6 and Paragraph 9.1.10.4 is required. Refer to [Figure 9.1.9.6](#).
 - (4) For wrapping of a framed opening prior to window installation, refer to [Figure 9.1.9.6](#).
 - (5) For sealant at head for Very High and Extra High wind zones, refer to [Figure 9.1.10.1\(c\)](#).

Wall claddings

Figure 9.9.9.3: Enclosed balustrade-to-wall junction for EIFS

Paragraph [9.9.9.3](#) and [Table 4.5.1.1](#)

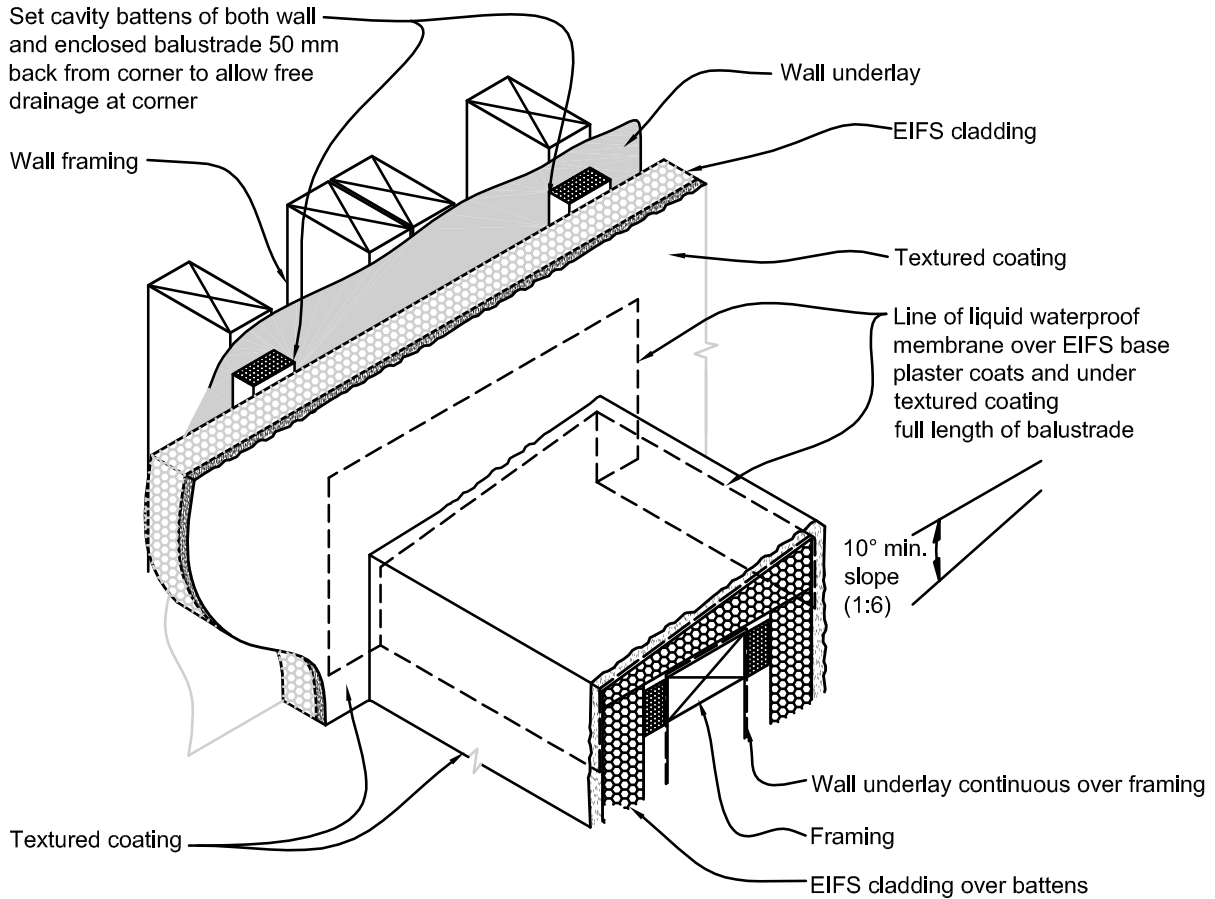

Note: (1) For framing and bridge over a drained cavity, refer to [Figure 6.2.3.1A](#) and [Figure 6.2.3.1B](#).

Figure 9.9.9.4: Parapet with metal capping for EIFS

Paragraphs [9.9.9.3](#), [9.9.9.4](#), and [Table 4.5.1.1](#)

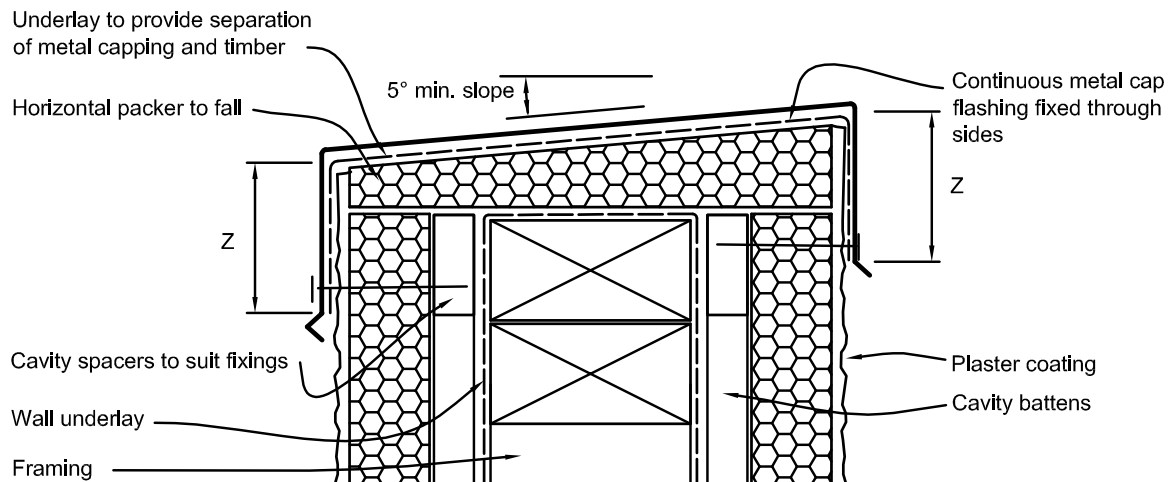

Note: (1) For dimension Z, refer to [Table 4.5.1.1](#)

Construction moisture

Part 10. Construction moisture

10.1 Managing construction moisture

10.1.1 Moisture in materials

10.1.1.1 Moisture contained in the *building* structure at completion of *construction* shall not be permitted to damage the *building elements*.

10.1.1.2 Construction moisture includes the moisture contained in:

- a) timber products as a result of a treatment or manufacturing process; and
- b) green timber, and timber or other materials that have been exposed to the weather; and
- c) concrete, mortar or plaster that is not completely cured.

10.1.2 Maximum acceptable moisture contents

10.1.2.1 The maximum moisture contents shall be:

- a) for timber *framing* at the time of installing interior *linings*, the lesser of:
 - i) 20% for insulated *buildings* or 24% for non-insulated *buildings*, as applicable, or
 - ii) as specified in NZS 3602; and
- b) for timber weatherboards and exterior joinery, 20% at the time of painting; and
- c) for reconstituted wood products, 18% at all times; and
- d) for concrete floors, sufficiently dry to give a relative humidity reading of less than 75% at the time of laying fixed floor coverings.

COMMENT: Some manufacturers of timber or other wall or floor components may recommend lower moisture contents for their products. It is advisable to use the manufacturer's moisture content requirements, if these are lower than those required by this paragraph.

10.2 Measuring moisture content

10.2.1 Timber

10.2.1.1 Measurement shall be by the recommended procedure in the Scion (New Zealand Forest Research Institute) publication "Measuring the moisture content of wood" using electrical resistance type moisture meters with insulated probes. Representative samplings of measurements shall be taken:

- a) with meters calibrated to AS/NZS 1080.1 Appendix E; and
- b) by inserting probes to at least 1/3 the depth of timber being measured, at a distance exceeding 200 mm from board ends; and
- c) using correction factors for timber species, temperature, and treatment type (outlined in Scion publication above).

COMMENT: For convenience of site measurement, readings of moisture content can be compared against a 'control' *framing* sample of known acceptable moisture content. The comparative readings must be taken during the same test period, be of the same framing type, and using the same resistance moisture meter. This method of moisture testing may be appropriate for non-boron treated *framing*, or processed timber *framing*.

Construction moisture

10.2.2 Concrete floors

- 10.2.2.1 Measurement shall be made in accordance with BRANZ Bulletin 330 “Thin Flooring Materials” using hygrometers calibrated to ASTM E104.

References

Appendix A. References

For the purposes of Building Code compliance, the standards referenced in this acceptable solution must be the editions, along with their specific amendments, listed below.

Standards New Zealand		Where quoted
AS/NZS 1734:1997	Aluminium and aluminium alloys – Flat sheet, coiled sheet and plate	4.2.3.1 , 8.3.2.4 , 8.4.2.3 , 9.6.2.3
AS/NZS 2269.0:2008	Plywood – Structural	8.5.2.1 , 9.3.5.3 , 9.8.2.2
NZS 2295:2006	Pliable, Permeable Building Membranes	8.1.3.1 , Table C.2.1.1
AS/NZS 2699.1:2000	Built-in components for masonry construction - Wall ties	Table 9.2.7.1A
AS/NZS 2699.3:2002	Built-in components for masonry construction - Lintels and shelf angles (durability requirements)	Table 9.2.9.4A
AS/NZS 2728:2013	Prefinished/prepainted sheet metal products for interior/exterior building applications – Performance requirements	8.3.2.3 , 8.3.2.4 , 9.6.2.3 , 9.6.2.4 , Table C.1.1.1A , 4.2.1.2 Comment, 8.4.2.1 Comment, 9.6.2.1 Comment
AS/NZS 2904:1995	Damp-proof courses and flashings Amendment 1	4.2.11.2 , 9.2.4.2
NZS 3602:2003	Timber and wood-based products for use in building	9.1.9.2 , 9.4.2.2 , 9.4.9.1 , 9.4.7.3 , 9.8.2.2 , 10.1.2.1 , Table C.2.1.1
NZS 3604:2011	Timber framed buildings	1.1.1.1 , 1.1.1.2 , 1.1.2.5 , 7.3.1.2 , 8.3.2.4 , 9.1.2.8 , 9.2.1.2 , 9.2.7.3 , 9.2.9.4 , 9.3.1.2 , C.3.1.2 , Definitions , Table 3.1.2.1 , Table 3.1.3.1 , Table 9.1.2.1 , Table 9.2.7.1A , Table C.1.1.1A , 4.2.1.2 Comment, 8.4.2.1 Comment, 8.4.4.2 Comment, 8.5.1.3 Comment, 9.1.2.4 Comment, 9.1.9.1 Comment, 9.6.2.1 Comment
NZS 3617:1979	Specification for profiles of weatherboards, fascia boards and flooring	9.4.1.2
AS/NZS 4020:2005	Testing of products for use in contact with drinking water	8.1.1.2 Comment
NZS 4206:1992	Concrete interlocking roofing tiles	8.2.2.1 , 8.2.3.1 , 8.2.3.2

References

Standards New Zealand		Where quoted
NZS 4210:2001	Code of practice for masonry construction: materials and workmanship, Amendment 1	9.2.2.3 , 9.2.7.1
NZS 4217:1980	Pressed metal tile roofs	8.3.2.1
SNZ HB 4236:2002	Masonry veneer wall cladding	9.2.2.1 , Definitions , Table 3.1.3.2
NZS 4251.1:2007	Solid plastering – Part 1: Cement plasters for walls, ceilings and soffits	9.3.1.2 , 9.3.2.1 , 9.3.3.2 , 9.3.5.3 , 9.3.5.4
AS/NZS 4256.2:1994	Plastic roof and wall cladding materials – Part 2: Unplasticized polyvinyl chloride (uPVC) building sheets	4.2.2.2 , 4.2.2.3
AS/NZS 4534:2006	Zinc and zinc/aluminium-alloy coatings on steel wire	9.1.7.10
AS/NZS 4858:2004	Wet area membranes	9.7.8.4 , 9.9.3.5 , 9.9.9.3
These standards can be accessed from www.standards.govt.nz .		
Standards Australia		Where quoted
AS 1366.3:1992	Rigid cellular plastics sheets for thermal insulation – Part 3: Rigid cellular polystyrene – moulded (PC/PS-M) Amendment 1	9.9.2.2
AS 1366.4:1989	Rigid cellular plastics sheets for thermal insulation – Part 4: Rigid cellular polystyrene – extruded (RC/PS-E)	9.9.2.2
AS 1397:2011	Continuous hot-dip metallic coated steel sheet and strip – Coatings of zinc and zinc alloyed with aluminium and magnesium, Amendment 1	4.2.5.1 , Table C.1.1.1A
AS 1566:1997	Copper and copper alloys – Rolled flat products	4.2.7.1
AS 1804:1976	Soft lead sheet and strip	4.2.8.1
AS 2049:2002	Roof tiles	8.2.2.1
AS 2050:2002	Installation of roof tiles	8.2.3.1
AS 3566.2:2002	Self-drilling screws for the building and construction industries – Part 2: Corrosion resistance	8.4.6.1 , 8.4.7.1 , 9.6.4.1 , C.3.1.3 , Table C.1.1.1A
AS 3730.7:2006	Guild to the properties of paints for buildings – Part 7: Latex – Exterior – Flat	9.3.6.1 , 9.4.9.2 , 9.5.6.1 , 9.7.4.4 , 9.7.5.2 , 9.8.9.2 , 9.9.2.1 , 9.9.5.6
AS 3730.8:2006	Guild to the properties of paints for buildings – Part 8: Latex – Exterior – Low-gloss	9.3.6.1 , 9.4.9.2 , 9.5.6.1 , 9.7.4.4 , 9.7.5.2 , 9.8.9.2 , 9.9.2.1 , 9.9.5.6
AS 3730.9:2006	Guild to the properties of paints for buildings – Part 9: Latex – Exterior – Semi-gloss	9.3.6.1 , 9.4.9.2 , 9.5.6.1 , 9.7.4.4 , 9.7.5.2 , 9.8.9.2 , 9.9.2.1 , 9.9.5.6
AS 3730.10:2006	Guild to the properties of paints for buildings – Part 10: Latex – Exterior – Gloss	9.3.6.1 , 9.4.9.2 , 9.5.6.1 , 9.7.4.4 , 9.7.5.2 , 9.8.9.2 , 9.9.2.1 , 9.9.5.6

References

Standards Australia		Where quoted
AS 4046.9:2002	Methods of testing roof tiles – Part 9: Determination of dynamic weather resistance	8.2.3.4
AS 4680:2006	Hot-dip galvanised (zinc) coatings on fabricated ferrous articles	9.9.3.2 , Table C.1.1.1A
These standards can be accessed from www.standards.org.au .		
British Standards Institution		Where quoted
BS 6538.3:1987	Air permeance of paper and board – Part 3: Method for determination of air permeance using the Garley apparatus	Table C.2.1.1
BS EN 988:1997	Zinc and zinc alloys. Specification for rolled flat products for building	4.2.9.2
These standards can be accessed from www.standards.govt.nz .		
American Society for Testing and Materials		Where quoted
ASTM C1330-02	Standard Specification for Cylindrical Sealant Backing for Use with Cold Liquid Applied Sealants	9.1.5.1 Comment, 9.2.4.2 Comment, 9.2.8.4 Comment
ASTM C1549-09	Standard Test Method for Determination of Solar Reflectance Near Ambient Temperature Using a Portable Solar Reflectometer	2.1.3.1
ASTM D1667-05	Standard Specification for Flexible Cellular Materials— Poly (Vinyl Chloride) Foam (Closed-Cell)	9.1.9.9
ASTM D2240-05	Standard Test method for Rubber Property	9.1.9.9
ASTM D6134-07	Standard Specification for Vulcanised Rubber Sheets Used in Waterproofing Systems	4.2.10.2 , 8.5.2.2
ASTM E96-05	Standard Test Methods for Water Vapor Transmission of Materials	Table C.2.1.1
ASTM E104-02	Standard Practice for Maintaining Constant Relative Humidity by Means of Aqueous Solutions	10.2.2.1
ASTM G154-06	Standard Practice for Operating Fluorescent Light Apparatus for UV Exposure of Nonmetallic Materials	9.1.9.9
ASTM G155-05	Standard Practice for Operating Xenon Arc Light Apparatus for UV Exposure of Nonmetallic Materials	9.1.9.9
These standards can be accessed from http://www.astm.org .		
BRANZ		Where quoted
BRANZ Bulletin 330:1995	Thin flooring materials – 2 Preparation and laying. Appendix 1	10.2.2.1
BRANZ Bulletin 411:2001	Recommended timber cladding profiles	9.4.1.2
BRANZ EM4:2005	Evaluation method for jointing systems for flush finished fibre cement sheet	9.7.5.2

References

BRANZ		Where quoted
BRANZ EM5:2005	Evaluation method for adhesives and seam tapes for butyl and EPDM rubber membranes	8.5.2.2
BRANZ EM6:2011	Evaluation method for window and door support mechanisms or bars	9.1.10.4, Definitions, Figure 9.3.9.1, Figure 9.4.7.1, Figure 9.4.7.2, Figure 9.5.4.3, Figure 9.6.6.8, Figure 9.6.7.9A, Figure 9.7.7.1B, Figure 9.9.8.1B
These documents can be accessed from http://www.branz.co.nz .		
Other organisations		Where quoted
AC148:2001	ICBO Evaluation Services Inc. Acceptance criteria for flashing materials.	4.2.12.1, 9.1.4.1, 9.9.3.5
Federal Specification TT-S-00230C	Elastomeric type, cold applied single component for caulking, sealing, and glazing in buildings, building areas (plazas, decks, pavements), and other structures	4.4.4.1, 8.4.9.6, 9.1.5.1, 9.1.8.3, 9.2.8.4, 9.5.3.5, 9.6.5.4, 9.9.2.1, 9.9.7.1
ISO 9223:1992	Corrosion of metals and alloys; corrosivity of atmospheres; classification	4.2.1.2, 8.3.2.4, 8.4.2.1, 9.6.2.1, Table C.1.1.1A
ISO 11600:2002	Building Construction – Jointing products Classification and requirements for sealants	4.4.4.1, 8.4.9.6, 9.1.5.1, 9.1.8.3, 9.2.8.4, 9.5.3.5, 9.6.5.4, 9.9.2.1, 9.9.7.1
ISO/TS 15510:2003	Stainless steels – chemical composition	4.2.6.1
New Zealand Metal Roofing Manufacturers Inc., “New Zealand Metal Roof and Wall Cladding Code of Practice”, 2008		4.4.4.1, 4.2.1.5 Comment, 4.4.3.4 Comment, 8.1.6.1 Comment, 8.3.1.1 Comment, 8.4.1.1 Comment, 8.4.9.7 Comment, 8.4.10.2 Comment, 8.4.10.3 Comment, 8.4.11.3 Comment, 8.4.12.3 Comment
SCION (New Zealand Forest Research Institute) FRI Bulletin No. 200, “Measuring the moisture content of wood”, 1996		10.2.2.1

Definitions

Appendix B. Definitions

These definitions are specific to this acceptable solution. Other defined terms italicised within the definitions are provided in clause A2 of the Building Code.

Term	Definition
Access route	A continuous route that permits people and goods to move between the apron or <i>construction</i> edge of the <i>building</i> to spaces within a <i>building</i> , and between spaces within a <i>building</i> .
Air seal	A continuous seal fitted between a window or door reveal and the surrounding <i>wall framing</i> to prevent the flow of air into the interior of the <i>building</i> .
Anti-ponding board	A board laid under the lowest row of concrete and clay roof tiles and supports the <i>roof underlay</i> .
Apron flashing	A near flat or sloping <i>flashing</i> with a vertical upstand, used at junctions between <i>roofs</i> and <i>walls</i> .
Attached garage	A garage that shares a common <i>wall</i> or <i>walls</i> with a habitable <i>building</i> , and is enclosed by <i>roof</i> and <i>wall claddings</i> that are continuous with the habitable part of the <i>building</i> .
Base metal thickness (BMT)	The thickness of the bare or base metal before any subsequent coating, such as galvanizing.
Bird's beak	A double fold applied to the edge of a horizontal metal <i>flashing</i> to stiffen the edge and to assist in deflecting moisture away from the <i>cladding system</i> below. Refer also Kick-out and Drip edge . COMMENT: A <i>bird's beak</i> is used at the bottom of a <i>capping</i> to deflect water away from the <i>enclosed balustrade cladding</i> .
Building	Has the meaning given to it by sections 8 and 9 of the Building Act 2004.
Building consent authority	Has the meaning ascribed to it by section 7 of the Building Act 2004.
Building element	Any structural and non-structural component or assembly incorporated into or associated with a <i>building</i> . Included are <i>fixtures</i> , <i>services</i> , <i>drains</i> , permanent mechanical installations for access, glazing, partitions, ceilings and temporary supports.
Butt flashing	A preformed <i>wall flashing</i> , used to flash windows and corners on horizontal profiled metal <i>wall cladding</i> . It is shaped to underflash the <i>cladding</i> , with the <i>cladding</i> butting against the exposed box portion of the <i>flashing</i> .
Cantilevered deck	A <i>deck</i> where no support is provided at the outer extremities of the <i>deck</i> . COMMENT: <i>Cantilevered decks</i> are often <i>constructed</i> by extending <i>framing</i> members through the <i>cladding</i> beyond the <i>building</i> face. <i>Cantilevered decks</i> are sometimes known as balconies.
Capping	A <i>flashing</i> formed to cover the top of an <i>enclosed balustrade</i> or <i>parapet</i> . Also known as a coping.
Cavity batten	A vertical packing member used to create a <i>drained cavity</i> as part of a <i>cladding system</i> .

Definitions

Term	Definition
Cavity wall	A term used to describe a <i>wall</i> that incorporates a <i>drained cavity</i> .
Cavity spacer	A short block used to provide intermittent support for fixings or pipe penetrations through a <i>drained cavity</i> , while not interrupting drainage within the cavity. It is required to be set to a slight fall (5° minimum from horizontal) to allow drainage of any moisture from the top.
Chimney	A <i>non-combustible</i> structure which encloses one or more <i>flues</i> , <i>fireplaces</i> or other heating appliances.
Cladding	The exterior weather-resistant surface of a <i>building</i> . COMMENT: Includes any supporting substrate and, if applicable, surface treatment.
Cladding system	The outside or exterior weather-resistant surface of a <i>building</i> ; including <i>roof cladding</i> and <i>roof underlays</i> , <i>wall cladding</i> and <i>wall underlays</i> , cavity components, rooflights, windows, doors, all penetrations, <i>flashings</i> , seals, joints, and junctions. Where required by this acceptable solution, this will include a drained cavity.
Construct	In relation to a <i>building</i> , includes to design, build, erect, prefabricate, and relocate the <i>building</i> ; and construction has a corresponding meaning.
Control joint	A joint designed to prevent damage by accommodating movement. See also Expansion joint .
Damp-proof course (DPC)	A strip of <i>durable vapour barrier</i> placed between <i>building elements</i> to prevent the passage of moisture from one element to another.
Damp-proof membrane (DPM)	A sheet material, coating or <i>vapour barrier</i> , having a low water vapour transmission, and used to minimise water and water vapour penetration into <i>buildings</i> . It is usually applied against concrete in contact with the ground and is also known as a concrete <i>underlay</i> .
Deck	An open platform projecting from an <i>external wall</i> of a <i>building</i> and supported by <i>framing</i> . It may be over enclosed internal spaces, or may be open underneath. Refer also Enclosed deck . It is also known as a balcony.
Direct fixed	A term used to describe a <i>wall cladding</i> attached directly to the <i>wall framing</i> , without the use of a <i>drained cavity</i> .
Dormer or Dormer window	A framed structure that projects from a sloping <i>roof</i> , and has a window at its outer end.
Drained cavity	A cavity space, immediately behind a <i>wall cladding</i> , that has vents at the base of the <i>wall</i> . It is also known as a drained and vented cavity and referred to in this acceptable solution as a cavity or drained cavity. A drained cavity assists drying by allowing water which occasionally penetrates the <i>wall cladding system</i> to drain to the exterior of the <i>building</i> , and any remaining moisture to dry by evaporation. Where this acceptable solution requires a nominal 20 mm drained cavity, the depth shall be between limits of 18 mm and 25 mm. For definition of masonry veneer cavity refer to SNZ HB 4236.

Definitions

Term	Definition
Drip edge	Fold(s) applied to the edge of a horizontal metal <i>flashing</i> to deflect moisture away from the <i>cladding system</i> below. Refer also Bird's beak and Kick-out .
Dwang	A short (usually horizontal) member fixed between <i>framing</i> timbers and also known as nogging.
Eaves	That part of the <i>roof construction</i> , including cladding, fascia, and eaves gutter (spouting), that extends beyond the exterior face of the <i>wall</i> .
EIFS (Exterior Insulation and Finish System)	A polystyrene sheet-based <i>cladding system</i> that uses mesh reinforced polymer-modified cement-based or polymer-based plaster base coats and a protective top coating.
Electrolytic corrosion	Galvanic corrosion commonly resulting from the contact of two dissimilar metals when an electrolyte such as water is present.
Enclosed balustrade	A timber-framed barrier with <i>cladding</i> across all exposed faces. Refer also Parapet .
Enclosed deck	A <i>deck</i> , whether over an interior or exterior space, that has an impermeable upper surface and is closed on the underside. It may also be known as a balcony.
Envelope complexity	The categorisation of the complexity of the total <i>building envelope</i> into one of four classes depending on the particular features of the <i>building</i> as specified in this acceptable solution.
EPDM (Ethylene Propylene Diene Monomer)	A thermosetting synthetic rubber used as a resilient part of a sealing washer, or as a <i>roof membrane</i> .
Expansion joint	A joint designed to prevent damage by accommodating movement. See also Control joint .
External wall	Any vertical exterior face of a <i>building</i> consisting of primary and/or secondary elements intended to provide protection against the outdoor environment.
Finished ground level (FGL)	The level of the ground against any part of a <i>building</i> after all backfilling and/or landscaping and/or surface paving has been completed.
Fire	The state of combustion during which flammable materials burn producing heat, toxic gases, or smoke or flame or any combination of these.
Fire stop	A material or method of construction used to restrict the spread of fire within or through <i>fire separations</i> , and having a <i>FRR</i> no less than that of the <i>fire separation</i> . <i>Fire stops</i> are mainly used to seal around penetrations, but can also be used to seal narrow gaps between <i>building elements</i> .
Flashing	A component, formed from a rigid or flexible <i>waterproof</i> material, that drains or deflects water back outside the <i>cladding system</i> .
Flexible flashing tape	A flexible self-adhesive <i>waterproof</i> tape. Usually used as an accessory for <i>wall underlays</i> , to seal corners and intersections.
Flush-finished	The description of a <i>cladding</i> and joints system which relies on a protective coating applied to the face of the <i>cladding</i> to prevent the penetration of water.
Framing	Timber members to which <i>lining</i> , <i>cladding</i> , flooring, or decking is attached; or which are depended upon for supporting the structure, or for resisting forces applied to it.

Definitions

Term	Definition
Hem	A flat fold, not completely closed, applied to the edge of a metal <i>flashing</i> .
Hidden gutter	A gutter located within the boundaries of the <i>roof framing</i> that may also be known as secret gutters or internal gutters. See also Valley gutters . COMMENT: Hidden gutters are distinct from gutters or spouting that are externally located beyond the bounds of the <i>roof</i> and <i>wall framing</i> .
Hook	An open fold applied to the edge of a metal flashing. COMMENT: A <i>hook</i> is distinct from a <i>hem</i> , as it is open at an acute angle rather than flattened.
Kick-out	A single fold applied to the edge of a horizontal metal <i>flashing</i> to deflect moisture away from the <i>cladding system</i> below. Refer also Bird's beak . COMMENT: A <i>stopend</i> assists the control of moisture by ensuring any moisture reaching the edge of the roofing is deflected from further entry.
Lining	The rigid sheet covering for a wall, ceiling, or other interior surface.
Masonry tiles	Clay or concrete tile <i>roof cladding</i> .
Masonry veneer	Clay or concrete block veneer <i>cladding</i> .
Membrane	A non-metallic material, usually synthetic, used as a fully supported <i>roof cladding</i> , deck surface or, in conjunction with other <i>claddings</i> , as gutters or <i>flashings</i> .
Parallel flashing	A <i>roof flashing</i> that runs along the <i>roof slope</i> , parallel to the <i>roof cladding</i> profile. Also known as a longitudinal flashing.
Parapet	A timber-framed wall that extends above the level of the <i>roof cladding</i> . Refer also Enclosed balustrade .
Purlin	A horizontal member laid to span across rafters or trusses, and to which the <i>roof cladding</i> is attached.
Rafter	A <i>framing timber</i> , normally parallel to the slope of the <i>roof</i> , providing support for sarking, purlins, or <i>roof cladding</i> .
Risk matrix	A table that allows the calculation of a <i>risk score</i> by the allocation and summing of scores for a range of design and location factors applying to a specific <i>building</i> design.
Risk score	An aggregated numerical score for a proposed <i>building</i> as defined by this acceptable solution. The risk score is determined by completion of the <i>risk matrix</i> .
Roof	That part of a <i>building</i> having its upper surface exposed to the outside and at an angle of 60° or less to the horizontal.
Roof underlay	An absorbent permeable <i>building paper</i> that absorbs or collects condensation or water in association with <i>roof cladding</i> performance.
Saddle flashing	A <i>flashing</i> used to <i>weatherproof</i> the junction between a horizontal and vertical surface.

Definitions

Term	Definition
Scupper	An opening in a <i>parapet</i> or <i>enclosed balustrade</i> to allow water to drain into a rainwater head.
Sill support bar	A bar or mechanism complying with EM6, E2/VM1, and clause B2 Durability of the Building Code; and used to support the weight of aluminium window and door joinery that is installed over drained cavities.
Soft edge	A compatible soft edging seamed onto <i>flashings</i> to provide closure to profiled <i>cladding</i> .
Specific design	Design and detailing for compliance with the Building Code, of a proposed part or parts of a <i>building</i> which are not shown in this acceptable solution
Stanchion	A connecting device, fixed into the structure of a building, that provides support for handrails, aerials and similar structures.
Stopend	A turn-up at the upper edge of profiled metal <i>cladding</i> , or at the end of gutters and some types of <i>flashings</i> . <div style="border: 1px solid black; padding: 5px; margin: 5px 0;"> <p>COMMENT: A <i>stopend</i> assists the control of moisture by ensuring any moisture reaching the edge of the roofing is deflected from further entry.</p> </div>
Storey	That portion of a <i>building</i> included between the upper surface of any floor and the upper surface of the floor immediately above, except the top storey shall be that portion of a <i>building</i> included between the upper surface of the topmost floor and the ceiling or roof above.
Stucco	A <i>wall cladding system</i> formed from reinforced solid plaster over a rigid or nonrigid backing.
Stud	A vertical <i>framing timber</i> .
Transverse flashing	A <i>roof flashing</i> that runs across the <i>roof slope</i> , at right angles to the <i>roof cladding profile</i> .
Trapezoidal	A type of profiled metal <i>cladding</i> with symmetrical or asymmetrical crests, with troughs between the crests.
Trough profile	e A type of profiled metal cladding comprising vertical ribs with flat, or lightly profiled pans between the ribs. Also known as ribbed, secret fixed, or tray profile.
Underlay	The material used behind a <i>roof</i> or <i>wall cladding</i> . Also refer to Wall underlay and Roof underlay .
Valley gutter	A gutter running down the valley formed by the intersection of two pitched <i>roof surfaces</i> .
Vapour barrier	Sheet material or coating having a low water-vapour transmission, and used to minimise water-vapour penetration in <i>buildings</i> .
Wall	Refer to External wall .
Wall underlay	A building paper, synthetic material or rigid sheathing used as part of the <i>wall cladding system</i> to assist the control of moisture by ensuring moisture which occasionally penetrates the <i>wall cladding</i> is directed back to the exterior of the <i>building</i> .
Waterproof and waterproofing	The complete and total resistance of a <i>building element</i> to the ingress of any moisture.

Definitions

Term	Definition
Weathertightness and weathertight	<p>Terms used to describe the resistance of a <i>building</i> to the weather.</p> <p><i>Weathertightness</i> is a state where water is prevented from entering and accumulating behind the <i>cladding</i> in amounts that can cause undue dampness or damage to the <i>building elements</i>.</p> <div style="border: 1px solid black; padding: 5px;"> <p>COMMENT: The term <i>weathertightness</i> is not necessarily the same as <i>waterproof</i>.</p> <p>However, a <i>weathertight building</i>, even under severe weather conditions, is expected to limit moisture ingress to inconsequential amounts, insufficient to cause undue dampness inside <i>buildings</i> and damage to <i>building elements</i>. Moisture that may occasionally enter is able to harmlessly escape or evaporate.</p> </div>
Wind zone	<p>Categorisation of wind force experienced on a particular site as determined in NZS 3604 Section 5.</p> <div style="border: 1px solid black; padding: 5px;"> <p>COMMENT: Maximum ultimate limit state speeds are:</p> <p>Low <i>wind zone</i> = wind speed of 32 m/s</p> <p>Medium <i>wind zone</i> = wind speed of 37 m/s</p> <p>High <i>wind zone</i> = wind speed of 44 m/s</p> <p>Very High <i>wind zone</i> = wind speed of 50 m/s</p> <p>Extra High <i>wind zone</i> = wind speed of 55 m/s.</p> <p><i>Specific design</i> is required for wind speeds greater than 55 m/s.</p> </div>

Material tables

Appendix C. Material tables

C.1 Materials

C.1.1 Material selection

- C.1.1.1 Materials used to *construct* the *building envelope* shall be:
- In accordance with the durability requirements of Building Code clause B2 Durability; and
 - suitable for their end-use, location, and environment as shown in [Table C.1.1.1A](#); and
 - compatible with adjoining materials as shown in [Table C.1.1.1B](#) and [Table C.1.1.1C](#).
- C.1.1.2 Refer to the relevant parts of this acceptable solution for *cladding* and *flashings* for the material and coating specifications.

C.2 Underlays and membranes

C.2.1 Roof underlays, wall underlays, and DPC/DPM

- C.2.1.1 The properties of *roof underlays*, *wall underlays*, and *DPC/DPM* shall be in accordance with [Table C.2.1.1](#).

C.3 Fixing selection

C.3.1 Wall claddings

- C.3.1.1 Fixings for *wall claddings* shall be selected in accordance with [Table C.3.1.1](#) except where otherwise required by this acceptable solution.
- C.3.1.2 Refer to NZS 3604 for fixing types where *claddings* act as structural bracing.
- C.3.1.3 Minimum fixing materials for non-structural *claddings*, shall be galvanised steel for exposure zones B,C, and D (as outlined in NZS 3604). Galvanised nails shall be hot-dipped galvanised; galvanised screws shall be mechanically zinc plated in accordance with AS 3566.2 Class 4.
- C.3.1.4 Where the *cladding* is a corrosive timber, such as western red cedar or redwood, or is treated with copper based ACQ or CuAz preservatives, use stainless steel. Stainless steel nails shall have annular grooves to provide similar withdrawal resistance to hot-dip galvanised nails.

COMMENT: Some manufacturers may require more durable fixings than those stated in [Table C.3.1.1](#) or in NZS 3604 to maintain product warranties.

Material tables

Table C.1.1.1A: Material selection (see notes on next page)

Paragraphs [2.1.1.1](#), [4.2.1.2](#), [4.2.1.5](#), [4.2.4.1](#), [4.2.5.1](#), [4.2.9.1](#), [4.2.10.1](#), [4.2.11.1](#), [4.3.1.1](#), [8.1.2.2](#), [8.2.3.3](#), [8.2.2.3](#), [8.3.2.2](#), [8.4.2.1](#), [8.3.2.2](#), [8.4.7.1](#), [9.1.9.8](#), [9.4.3.2](#), [9.6.2.1](#), [9.6.4.1](#), [9.8.5.1](#), and [C.1.1.1](#)

Category	Material	Exposure (2),(3),(5),(7)	Type	Acceptable exposure zone ^{(1),(4),(5),(7)} for 15 years	Acceptable exposure zone ^{(1),(4),(5),(7)} for 50 years for hidden elements	
Claddings and flashings	Aluminium, zinc	Hidden ⁽³⁾		B,C,D,E	B,C,D,E	
	Copper, lead, or stainless steel	Exposed Sheltered				
	Factory painted					
	Aluminium-zinc-magnesium	Hidden ⁽¹⁰⁾	Type 4	B,C,D,E	B,C,D	
	(combinations) coated or galvanised	Hidden ⁽¹⁰⁾	Type 6	B,C,D,E	B,C,D,E	
	steel, to AS 1397 and AS/NZS 2728 with	Exposed ⁽⁹⁾	Type 4	B,C,D		
	AM100, ZM274, and AZ150 minimum	Exposed ⁽⁹⁾	Type 6	B,C,D,E		
	coatings	Sheltered	Type 4	B,C		
		Sheltered	Type 6	B,C,D		
	Pressed metal tiles coated to minimum	Exposed	Type 6	B,C,D,E		
	AZ150 or AM100 to AS 1397, AS/NZS	Sheltered	Type 6	B,C,D		
	2728 or with post-form factory painting					
	to Paragraph 8.3.2.3 .					
	Non-factory painted					
	Aluminium-zinc-magnesium	Hidden ⁽¹⁰⁾		B,C,D,E	B,C,D	
(combinations) coated steel, to	Exposed ⁽⁹⁾		B,C			
AS 1397 with AZ150 or AM125 minimum	Sheltered		B			
coatings						
Galvanised steel Z450 to AS 1397	Hidden ⁽¹⁰⁾		B,C,D	B,C		
	Exposed ⁽⁹⁾		B,C			
	Sheltered		B			
Non-metallic						
Bituminous material, or uPVC	Hidden		B,C,D,E	B,C,D,E		
	Exposed (uPVC)		B,C,D,E			
	Sheltered(uPVC)		B,C,D,E			
Butyl rubber	Hidden		B,C,D,E	B,C,D,E		
	Exposed		B,C,D,E			
	Sheltered		B,C,D,E			
Fixings⁽⁸⁾	Aluminium, bronze, and stainless steel	Hidden		B,C,D,E	B,C,D,E	
	(Types 304 and 316) ⁽¹¹⁾	Exposed		B,C,D,E		
		Sheltered		B,C,D,E		
	Nails – Hot-dip galvanised steel to	Hidden ^{(6),(10)}		B,C,D	B,C	
	AS/NZS 4680	Exposed		B,C		
		Sheltered		B		
Screws – galvanised steel, painted or	Hidden ^{(6),(10)}	Class 3	B,C,D,E ^{(4),(5)}	B,C,D,E		
unpainted, to AS 3566.2	Exposed	Class 4	B,C,D			
	Sheltered	Class 4	B,C			

Material tables

Notes:

- (1) Exposure zones are as per NZS 3604 Section 4.
- (2) Refer to manufacturer's information for maintenance requirements in Exposed and Sheltered locations.
- (3) The term "hidden" means concealed behind another element such that no part is visible. Hidden elements require a 50 year durability under the Building Code. The term "exposed" means having surfaces exposed to rain washing. The term 'sheltered' means being visible, but not rain washed. For diagrammatic outline, refer NZS 3604 Figure 4.3(a). Exposed and sheltered elements require a 15 year durability. Where an element can be categorised as both 'sheltered' and 'exposed', the 'sheltered' condition will apply.
- (4) AS/NZS 2728 lists atmospheric classes derived from ISO 9223 for Australia and New Zealand, determined by exposure to wind-driven sea-spray. NZS 3604 references atmospheric classes B (Low), C (Medium) and D (High). E2/AS1 references atmospheric zones B,C,D,E. For the purposes of *cladding* selection, Zone E (Severe marine classified as breaking surf beach fronts) has been included. Designers must consult metal supplier's information for specific durability requirements of sites in Zone E.
- (5) The geographic limits of atmospheric classes in NZS 3604 and AS/NZS 2728 may vary. Table C.1.1.1A uses the limits outlined in NZS 3604.
- (6) Includes fixings protected by putty and an exterior paint system of primer, undercoat and two top coats of paint.
- (7) Microclimates based on evidence from adjacent structures of corrosion caused by industrial or geothermal atmospheres are outside the scope of this acceptable solution.
- (8) Refer to [Table C.1.1.1B](#) and [Table C.1.1.1C](#) for compatibility of fixings with metal *claddings*.
- (9) *Roof* only. Coated steel wall claddings must be considered as 'sheltered'.
- (10) Hidden steel coated elements in ventilated cavities in zones D and E (exposure to salt air) must be considered as 'sheltered'
- (11) The use of stainless steel fixings is not recommended by steel manufacturers for use with coated steel in severe marine and industrial environments, as they are considered to cause deterioration.

Material tables

Table C.1.1.1B: Compatibility of materials in contact

Paragraphs 2.1.1.1, 4.2.1.3, 4.2.1.5, 4.2.9.1, 4.2.10.1, 4.3.1.1, 4.4.4.1, 7.4.2.2, 8.1.2.2, 8.2.2.3, 8.4.7.1, 8.4.9.1, 9.1.9.8, 9.6.5.6, 9.8.5.1 and C.1.1.1 and Table C.1.1.1A

Materials ⁽¹⁾	Aluminium: anodised or mill-finish	Aluminium: coated ⁽²⁾	Butyl Rubber and EDPM	CCA-treated timber ⁽³⁾	Cedar	Cement plaster (uncoated)	Ceramic tiles (cement grout)	Clay bricks (cement mortar)	Concrete old (unpainted)	Concrete green (unpainted)	Copper and brass	Glass	Glazed roof tiles	Lead (including lead-edged) unpainted	Plastics	Stainless steel	Steel, galvanised coil-coated	Steel, galvanised (unpainted)	Zinc	Zinc-aluminium-magnesium (combinations), coated ⁽²⁾	Zinc-aluminium-magnesium (combinations) unpainted
Aluminium: anodised or mill-finish	✓	✓	✓	✗	✓	✗	✗	✗	✓	✗	✗	✓	✓	✗	✓	B	✓	✓	✓	✓	✓
Aluminium: coated ⁽²⁾	✓	✓	✓	B	✓	✗	✗	✗	✓	✗	✗	✓	✓	B	✓	B	✓	✓	✓	✓	✓
Butyl Rubber and EDPM	✓	✓	✓	✓	✓	✓	✓	✓	✓	✓	✓	✓	✓	✓	✓	✓	✓	✓	✓	✓	✓
CCA-treated timber ⁽³⁾	✗	B	✓	✓	✓	✓	✓	✓	✓	✓	✓	✓	✓	✓	✓	✓	B	✗	✗	B	✗
Cedar	✓	✓	✓	✓	✓	✓	✓	✓	✓	✓	✓	✓	✓	✓	✓	✓	✓	✗	✗	✓	✗
Cement plaster (uncoated)	✗	✗	✓	✓	✓	✓	✓	✓	✓	✓	✓	✓	✓	✗	✓	✓	✓	✓	✓	✓	✗
Ceramic tiles (cement grout)	✗	✗	✓	✓	✓	✓	✓	✓	✓	✓	✓	✓	✓	✓	✓	✓	✓	✓	✓	✓	✗
Clay bricks (cement mortar)	✗	✗	✓	✓	✓	✓	✓	✓	✓	✓	✓	✓	✓	✓	✓	✓	✓	✓	✓	✓	✗
Concrete old (unpainted)	✓	✓	✓	✓	✓	✓	✓	✓	✓	✓	✓	✓	✓	✓	✓	✓	✓	✓	✓	✓	✓
Concrete green (unpainted)	✗	✗	✓	✓	✓	✓	✓	✓	✓	✓	✓	✓	✓	✗	✓	✓	✗	✗	✗	✗	✗
Copper and brass	✗	✗	✓	✓	✓	✓	✓	✓	✓	✓	✓	✓	✓	B	✓	B	✗	✗	✗	✗	✗
Glass	✓	✓	✓	✓	✓	✓	✓	✓	✓	✓	✓	✓	✓	✓	✓	✓	✓	✓	✓	✓	✓
Glazed roof tiles	✓	✓	✓	✓	✓	✓	✓	✓	✓	✓	✓	✓	✓	✓	✓	✓	✓	✓	✓	✓	✓
Lead (including lead-edged) unpainted	✗	B	✓	✓	✓	✗	✓	✓	✓	✗	B	✓	✓	✓	✓	B	B	B	B	B	✗
Plastics	✓	✓	✓	✓	✓	✓	✓	✓	✓	✓	✓	✓	✓	✓	✓	✓	✓	✓	✓	✓	✓
Stainless steel	B	B	✓	✓	✓	✓	✓	✓	✓	✓	B	✓	✓	B	✓	✓	B	✗	✗	B	B
Steel, galvanised coil-coated	✓	✓	✓	B	✓	✓	✓	✓	✓	✗	✗	✓	✓	B	✓	B	✓	✓	✓	✓	✓
Steel, galvanised (unpainted)	✓	✓	✓	✗	✗	✓	✓	✓	✓	✗	✗	✓	✓	B	✓	✗	✓	✓	✓	✓	✓
Zinc	✓	✓	✓	✗	✗	✓	✓	✓	✓	✗	✗	✓	✓	B	✓	✗	✓	✓	✓	✓	✓
Zinc-aluminium-magnesium (combinations), coated ⁽²⁾	✓	✓	✓	B	✓	✓	✓	✓	✓	✗	✗	✓	✓	B	✓	B	✓	✓	✓	✓	✓
Zinc-aluminium-magnesium (combinations) unpainted	✓	✓	✓	✗	✗	✗	✗	✗	✓	✗	✗	✓	✓	✗	✓	B	✓	✓	✓	✓	✓

Notes: (1) ✓ means materials are satisfactory in contact. ✗ means contact between materials is not permitted. A minimum gap of 5 mm is required to prevent moisture bridging. B means that contact shall be avoided in sea-spray zone or exposure zone D and E.

(2) Coated includes factory-painted, coil-coated and powder-coated.

(3) Includes copper azole and copper quaternary salts.

Material tables

Table C.1.1.1C: Compatibility of materials subject to run-off

Paragraph 2.1.1.1, 4.2.1.3, 4.2.1.5, 4.2.9.1, 4.2.10.1, 4.3.1.1, 4.4.4.1, 7.4.2.2, 8.1.2.2, 8.2.2.3, 8.4.9.1, 9.1.9.8, 9.6.5.6, 9.8.5.1 and C.1.1.1 and Table C.1.1.1A

Material that water flows onto (to the right)	Aluminium: anodised or mill-finish	Aluminium: coated ⁽²⁾	Butyl Rubber and EDPM	CCA-treated timber ⁽³⁾	Cedar	Cement plaster (uncoated)	Ceramic tiles (cement grout)	Clay bricks (cement mortar)	Concrete old (unpainted)	Concrete green (unpainted)	Copper and brass	Glass	Glazed roof tiles	Lead (including lead-edged) unpainted	Plastics	Stainless steel	Steel, galvanised coil-coated	Steel, galvanised (unpainted)	Zinc	Zinc-aluminium-magnesium (combinations), coated ⁽²⁾	Zinc-aluminium-magnesium (combinations) unpainted
Aluminium: anodised or mill-finish	✓	✓	✓	✓	✓	✓	✓	✓	✓	✓	✓	✓	✓	✓	✓	✓	✓	✓	✓	✓	✓
Aluminium: coated ⁽²⁾	✓	✓	✓	✓	✓	✓	✓	✓	✓	✓	✓	✓	✓	✓	✓	✓	✓	✓	✓	✓	✓
Butyl Rubber and EDPM	✓	✓	✓	✓	✓	✓	✓	✓	✓	✓	✓	✓	✓	✓	✓	✓	✓	✓	✓	✓	✓
CCA-treated timber ⁽³⁾	✗	✗	✓	✓	✓	✓	✓	✓	✓	✓	✓	✓	✓	✓	✓	✓	✗	✗	✗	✗	✗
Cedar	✓	✓	✓	✓	✓	✓	✓	✓	✓	✓	✓	✓	✓	✓	✓	✓	✓	✓	✓	✓	✓
Cement plaster (uncoated)	✗	✗	✓	✓	✓	✓	✓	✓	✓	✓	✓	A	✓	✗	✓	✓	✓	✓	✓	✓	✓
Ceramic tiles (cement grout)	✗	✗	✓	✓	✓	✓	✓	✓	✓	✓	✓	A	✓	✓	✓	✓	✓	✓	✓	✓	✓
Clay bricks (cement mortar)	✗	✗	✓	✓	✓	✓	✓	✓	✓	✓	✓	A	✓	✓	✓	✓	✓	✓	✓	✓	✓
Concrete old (unpainted)	✓	✓	✓	✓	✓	✓	✓	✓	✓	✓	✓	A	✓	✓	✓	✓	✓	✓	✓	✓	✓
Concrete green (unpainted)	✗	✗	✓	✓	✓	✓	✓	✓	✓	✓	✓	A	✓	✗	✓	✓	✗	✗	✗	✗	✗
Copper and brass	✗	✗	✓	✓	✓	✓	✓	✓	✓	✓	✓	✓	✓	✓	✓	✓	✗	✗	✗	✗	✗
Glass	✓	✓	✓	✓	✓	✓	✓	✓	✓	✓	✓	✓	✓	✓	✓	✓	✓	✓	✓	✓	✓
Glazed roof tiles	✓	✓	✓	✓	✓	✓	✓	✓	✓	✓	✓	✓	✓	✓	✓	✓	✓	✓	✓	✓	✓
Lead (including lead-edged) unpainted	✗	✗	✓	✓	✓	✓	✓	✓	✓	✓	✓	✓	✓	✓	✓	✓	✓	✓	✓	✓	✗
Plastics	✓	✓	✓	✓	✓	✓	✓	✓	✓	✓	✓	✓	✓	✓	✓	✓	✓	✓	✓	✓	✓
Stainless steel	✓	✓	✓	✓	✓	✓	✓	✓	✓	✓	✓	✓	✓	✓	✓	✓	✓	✓	✓	✓	✓
Steel, galvanised coil-coated	✓	✓	✓	✓	✓	✓	✓	✓	✓	✓	✓	✓	✓	✓	✓	✓	✓	✓	✓	✓	✓
Steel, galvanised (unpainted)	✓	✓	✓	✓	✓	✓	✓	✓	✓	✓	✓	✓	✓	✓	✓	✓	✓	✓	✓	✓	✓
Zinc	✓	✓	✓	✓	✓	✓	✓	✓	✓	✓	✓	✓	✓	✓	✓	✓	✓	✓	✓	✓	✓
Zinc-aluminium-magnesium (combinations), coated ⁽²⁾	✓	✓	✓	✓	✓	✓	✓	✓	✓	✓	✓	✓	✓	✓	✓	✓	✓	✓	✓	✓	✓
Zinc-aluminium-magnesium (combinations) unpainted	✓	✓	✓	✓	✓	✓	✓	✓	✓	✓	✓	✓	✓	✓	✓	✓	✓	✓	✓	✓	✓

Notes: (1) ✓ means materials are satisfactory in contact. ✗ means contact between materials is not permitted. A minimum gap of 5 mm is required to prevent moisture bridging. A means that etching or staining of glass may occur with run-off.

(2) Coated includes factory-painted, coil-coated and powder-coated.

(3) Includes copper azole and copper quaternary salts.

Material tables

Table C.2.1.1: Properties of roof underlays and wall underlays

Paragraphs [6.1.1.4](#), [8.1.3.1](#), [8.2.3.1](#), [8.2.3.2](#), [8.3.4.1](#), [8.4.5.1](#), [9.1.1.6](#), [9.1.3.2](#), [9.1.6.1](#), [9.1.6.2](#), [9.1.6.3](#), [9.1.6.4](#), [9.1.7.4](#), [9.2.4.1](#), [9.2.4.2](#), [9.2.5.4](#), [9.3.1.5](#), [9.3.4.1](#), [9.4.2.1](#), [9.4.3.1](#), [9.5.3.1](#), [9.6.6.1](#), [9.6.7.1](#), [9.6.7.2](#), [9.7.3.1](#), [9.8.3.1](#), [9.9.3.1](#), and [C.2.1.1](#)

Category	Application	Properties
<i>Roof underlay</i> ⁽¹⁾ (Bitumen and fire-retardant paper-based products) ⁽²⁾	All roofs	Vapour resistance ≤ 7 MNs/g (ASTM E96 B) Absorbency: NZS 2295 Section 3 Water resistance: NZS 2295 Section 3 pH of extract: NZS 2295 Section 3 Moisture shrinkage: NZS 2295 Section 3 Mechanical: NZS 2295 Section 3
Flexible wall underlay (includes paper and synthetic underlays)	<i>Wall claddings</i> over a cavity ⁽⁶⁾ , or Flexible underlays over rigid underlays (Paragraph 9.1.7.2), or <i>Direct fixed absorbent wall claddings</i> ⁽⁴⁾ (for example, timber, fibre cement)	Vapour resistance: NZS 2295 Section 2 Absorbency: No minimum requirement Water resistance: NZS 2295 Section 2 pH of extract: NZS 2295 Section 2 Moisture shrinkage: NZS 2295 Section 2 Mechanical: NZS 2295 Section 2
	Direct fixed non-absorbent claddings ⁽³⁾	Vapour resistance: NZS 2295 Section 2 Absorbency ≥ 100 g/m ² (NZS 2295) Water resistance: NZS 2295 Section 2 pH of extract: NZS 2295 Section 2 Moisture shrinkage: NZS 2295 Section 2 Mechanical: NZS 2295 Section 2
Rigid wall underlay (plywood ⁽⁵⁾ and fibre cement sheet)	<i>Wall claddings</i> over a cavity ⁽⁶⁾ , or <i>Direct fixed absorbent wall claddings</i> (for example, timber, fibre cement)	Vapour resistance ≤ 7 MNs/g (ASTM E96 B) Water resistance ≥ 20 mm (NZS 2295)
	Direct fixed non-absorbent claddings ⁽⁶⁾	Vapour resistance ≤ 7 MNs/g (ASTM E96 B) Absorbency ≥ 100 g/m ² (AS/NZS 4201.6) Water resistance ≥ 20 mm (AS/NZS 4201.4) pH of extract ≥ 6.0 and ≤ 9.0
Air barrier	Where no internal <i>linings</i>	Vapour resistance ≤ 7 MNs/g (ASTM E96 B) Absorbency ≥ 100 g/m ² (NZS 2295) ⁽⁷⁾ Water resistance ≥ 20 mm (NZS 2295) pH of extract ≥ 6.0 and ≤ 9.0 Moisture shrinkage ≤ 0.5% (NZS 2295) Mechanical edge tear strength (NZS 2295) Air resistance ≥ 0.1 MN s/m ³ (BS 6538.3)
DPC/DPM	All applications	Vapour resistance ≥ 90 MNs/g (ASTM E96)

Notes: (1) Metal roofs and direct fixed metal wall claddings require paper-based underlays.

(2) Excludes synthetic underlays.

(3) Use paper based underlays where directly behind (in contact with) profiled metal wall cladding.

(4) Excludes profiled metal wall cladding.

(5) Plywood to be treated in accordance with NZS 3602.

(6) Bitumen based products shall not be used in direct contact with LOSP-treated plywood

(7) Applies only to air barriers used with non-absorbent claddings.

Material tables

Table C.3.1.1: Fixing selection for wall claddings (continued on following pages)Paragraph [9.3.1.7](#), [9.4.3.2](#), [9.4.3.3](#), [9.4.5.4](#), [9.5.3.2](#), [9.7.3.1](#), [9.8.3.2](#), [9.9.3.2](#), [C.3.1.1](#), and [C.3.1.4](#)

Joint	Length (mm) ⁽¹⁾ x diameter (mm) and type ⁽²⁾	Minimum framing penetration	Fixing pattern	Additional requirements
Cavity battens (battens to framing)	N/A	N/A	N/A	See Note (3)
Stucco plaster				
Rigid backing to <i>framing</i>				Refer to: 9.3.5.3(c) and 9.3.5.4(d)
Metal lath to <i>framing</i>	40 x 2.4 FH nail or 40 x 2.8 FH nail	35 mm	150 mm centres	
Fibre cement weatherboards				
Weatherboard (direct fixed)	50 x 2.8 fibre cement nail	35 mm	Single fixing 20 mm above lower board, through both thicknesses	
Weatherboard (over cavity)	75 x 3.15 fibre cement nail	35 mm	Single fixing 20 mm above lower board, through both thicknesses	
Timber weatherboards: paint finish (direct fixed)				
Horizontal bevel-back	75 x 3.15 JH nail	35 mm	Single fixing 10 mm above top of lower board	
Horizontal rebated bevel-back	60 x 2.8 JH nail	35 mm	Single fixing 10 mm above top of lower board	
Horizontal rusticated	60 x 2.8 JH nail	35 mm	Single fixing 10 mm above top of lower board	
Vertical shiplap	60 x 2.8 JH nail	35 mm	Single fixing 10 mm from side lap (40 mm from edge of board)	See Note (4)
Board and batten: board	60 x 2.8 JH nail	35 mm	Single fixing in centre or nail clenched over each side.	See Note (4)
Board and batten: batten	75 x 3.15 JH nail	35 mm	Single fixing in centre of batten	See Note (4)
Timber weatherboards: paint finish (over cavity)				
Horizontal bevel-back	90 x 4.0 JH nail	35 mm	Single fixing 10 mm above top of lower board	
Horizontal rebated bevel-back	75 x 3.15 JH nail	25 mm	Single fixing 10 mm above top of lower board	

Notes:

(1) Nail lengths are designed for minimum penetration of *framing*. If thickness of the batten or *cladding* is varied, length shall be adjusted accordingly.

(2) RH is a rose head, JH is a jolt head, and FH is a flat head.

(3) Battens will be fixed by the *cladding* fixings, which will penetrate the *wall framing*. Battens will therefore need only temporary fixing until the *cladding* is fixed.

(4) *Dwangs* at maximum 480 mm centres.

Material tables

Table C.3.1.1: Fixing selection for wall claddings (continued on following page)Paragraph [9.3.1.7](#), [9.4.3.2](#), [9.4.3.3](#), [9.4.5.4](#), [9.5.3.2](#), [9.7.3.1](#), [9.8.3.2](#), [9.9.3.2](#), [C.3.1.1](#), and [C.3.1.4](#)

Joint	Length (mm) ⁽¹⁾ x diameter (mm) and type ⁽²⁾	Minimum framing penetration	Fixing pattern	Additional requirements
Horizontal rusticated	75 x 3.15 JH nail	35 mm	Single fixing 10 mm above top of lower board	
Timber weatherboards: stained or bare finish (direct fixed)				
Horizontal bevel-back	65 x 3.2 RH annular grooved nail	30 mm	Single fixing 10 mm above top of lower board	
Horizontal rebated bevel-back	50 x 3.2 RH annular grooved nail	35 mm	Single fixing 10 mm above top of lower board	
Horizontal rusticated	50 x 3.2 RH annular grooved nail	35 mm	Single fixing 10 mm above top of lower board	
Vertical shiplap	50 x 3.2 RH annular grooved nail	35 mm	Single fixing 10 mm from side lap(40 mm from edge of board)	See Note (4)
Board and batten: board	60 x 3.2 RH annular grooved nail	35 mm	Single fixing in centre of board	See Note (4)
Board and batten: batten	75 x 3.2 RH annular grooved nail	35 mm	Single fixing in centre of batten	See Note (4)
Timber weatherboards: stained or bare finish (over cavity)				
Horizontal bevel-back	85 x 3.2 RH annular grooved nail	30 mm	Single fixing 10 mm above top of lower board	
Horizontal rebated bevel-back	70 x 3.2 RH annular grooved nail	35 mm	Single fixing 10 mm above top of lower board	
Horizontal rusticated	70 x 3.2 RH annular grooved nail	35 mm	Single fixing 10 mm above top of lower board	
Vertical profiled metal (direct fixed)				Refer to 9.6.4
Horizontal profiled metal (direct fixed)				Refer to 9.6.4
Plywood sheet: paint finish (direct fixed)				
Plywood to stud or batten	50 x 2.8 FH nail	30 mm	150 mm centres to sides, 300 mm centres in middle	
External cover batten	60 x 2.8 RH annular grooved nail	30 mm	300 mm centres in centre of batten	

Notes:

(1) Nail lengths are designed for minimum penetration of *framing*. If thickness of the batten or *cladding* is varied, length shall be adjusted accordingly.

(2) RH is a rose head, JH is a jolt head, and FH is a flat head.

(4) *Dwangs* at maximum 480 mm centres.

Material tables

Table C.3.1.1: Fixing selection for wall claddings (continued from previous pages)

Paragraph 9.3.1.7, 9.4.3.2, 9.4.3.3, 9.4.5.4, 9.5.3.2, 9.7.3.1, 9.8.3.2, 9.9.3.2, C.3.1.1, and C.3.1.4

Joint	Length (mm) ⁽¹⁾ x diameter (mm) and type ⁽²⁾	Minimum framing penetration	Fixing pattern	Additional requirements
Plywood sheet: paint finish (over cavity)				
Plywood to stud or batten	60 x 2.8 FH nail	30 mm	150 mm centres to sides, 300 mm centres in middle	
External cover batten	60 x 2.8 JH nail	To cavity battens only	300 mm centres in centre of batten	
Plywood sheet: stained or bare finish (direct fixed)				
Plywood to stud or batten	50 x 2.8 FH nail	30 mm	150 mm centres to sides, 300 mm centres in middle	
External cover batten	60 x 3.2 RH annular grooved nail	30 mm	300 mm centres in centre of batten	
Plywood sheet: stained or bare finish (over cavity)				
Plywood to stud or batten	65 x 3.2 FH nail	30 mm	150 mm centres to sides, 300 mm centres in middle	
External cover batten	65 x 3.2 RH annular grooved nail	To cavity battens only	300 mm centres in centre of batten	
Fibre cement sheet: jointed (direct fixed)				
Sheet	40 x 2.8 fibre cement nail	30 mm	150 mm centres to sides, 300 mm centres in middle	
External cover batten	65 x 3.15 JH nail	30 mm	Single fixing in centre of batten	
Fibre cement: jointed (over cavity)				
Sheet	60 x 3.15 fibre cement nail	30 mm	150 mm centres to sides, 300 mm centres in middle	
External cover batten	65 x 3.15 JH nail	To cavity battens only	Single fixing in centre of batten	
Fibre cement sheet: flush-finish (over cavity)				
	60 x 3.15 fibre cement nail		Single fixing in centre of batten	
EIFS (over cavity)				
40 mm polystyrene sheet	90 x 4.0 nail	30 mm	Single fixing in centre of batten, and with 40 mm plastic washers on external corner fixings	

Notes:

(1) Nail lengths are designed for minimum penetration of *framing*. If thickness of the batten or *cladding* is varied, length shall be adjusted accordingly.

(2) RH is a rose head, JH is a jolt head, and FH is a flat head.

Examples using the risk matrix

Appendix D. Examples using the risk matrix

D.1 Simple buildings – example 1

D.1.1 Description of the building

D.1.1.1 The first example illustrates the use of the *risk matrix* for a simple traditionally styled *building* as shown in [Figure D.1.1.1](#).

D.1.1.2 The house in this example is a simple single *storey* L-shape and is considered low risk in terms of envelope complexity.

D.1.1.3 The eaves are 500 mm wide, and the site is in a High wind zone.

D.1.1.4 The covered porch is at ground level and so is considered low risk.

Figure D.1.1.1: Risk matrix example 1 for a simple building

Paragraph [D.1.1.1](#)

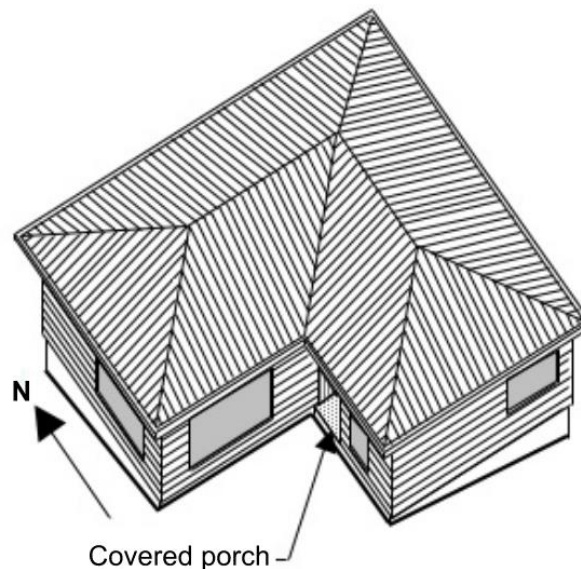

D.1.2 Calculation of the risk score

D.1.2.1 The risk score has been calculated for the south elevation in accordance with Paragraphs [3.1.2.1](#) and [3.1.3.1](#) and is shown in [Table D.1.2.1](#). This face scores as very low risk. A similar *risk score* would result for all elevations of this *building*.

Examples using the risk matrix

Table D.1.2.1: Risk matrix example 1 for the south face of a simple building

Paragraph [D.1.2.1](#)

Risk factor	Low risk		Medium risk		High risk		Very High risk		Subtotals for each risk factor ⁽¹⁾
	severity ⁽¹⁾	Score	Severity ⁽¹⁾	Score	severity ⁽¹⁾	Score	severity ⁽¹⁾	Score	
Wind zone (as per NZS 3604) ⁽¹⁾	0		0		1	1	2		1
Number of storeys	0	0	1		2		4		0
Roof/wall junction design	0	0	1		3		5		0
Eaves width	0		1	1	2		5		1
Envelope complexity	0	0	1		3		6		0
Deck design	0	0	2		4		6		0
Total risk score for use in Table 3.1.3.2									2

D.1.3 Cladding options

D.1.3.1 As all faces score low, *cladding* options from [Table 3.1.3.2](#) are:

- a) *direct fixed claddings*:
 - i) timber weatherboards – all types shown, and
 - ii) fibre cement weatherboards, and
 - iii) vertical profiled metal – corrugated and symmetrical *trapezoidal* only, and
 - iv) fibre cement sheet – not *flush-finished*, and
 - v) plywood sheet; and
- b) Wall *cladding* with a nominal 20 mm *drained cavity* (note: *claddings* in Extra High wind zones require rigid *underlays*):
 - i) *masonry veneer*, and
 - ii) *stucco*, and
 - iii) horizontal profiled metal – corrugated and *trapezoidal* only, and
 - iv) fibre cement – *flush-finished*, and
 - v) *EIFS*.

D.2 Moderately complex buildings – example 2

D.2.1 Description of the building

- D.2.1.1 The second example illustrates the use of the *risk matrix* for a moderately complex *building* as shown in [Figure D.2.1.1](#).
- D.2.1.2 Overall, the house in this example is still a relatively simple design with a single *cladding* type. It would be considered to be medium risk in terms of *envelope complexity*.
- D.2.1.3 The lean-to style room on the ground floor is quite simple but does introduce a roof-to-wall intersection which requires the correct *flashing* and particular care with the *kick-out* at the west end of the junction. This would make this factor very high risk.

Examples using the risk matrix

D.2.1.4 The timber *deck*, itself low risk, connects to the house at the first floor level, and so is considered to be medium risk. Any leaks at the connection points have an opportunity to enter the *wall* below.

D.2.1.5 The eaves are less than 450 mm wide, and the site is in a High *wind zone*.

Figure D.2.1.1: Risk matrix example 2 for a moderately complex building

Paragraph [D.2.1.1](#)

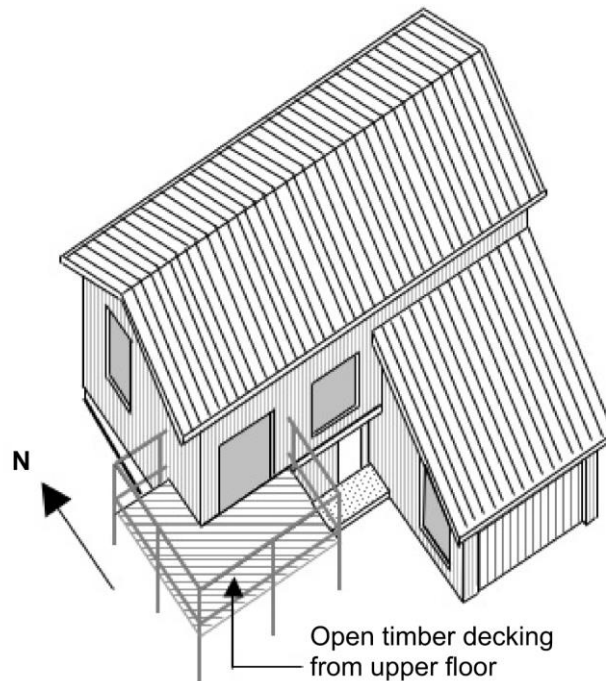

D.2.2 Calculation of the risk score

D.2.2.1 The risk score has been calculated for the south elevation in accordance with Paragraphs [3.1.2.1](#) and [3.1.3.1](#) and is shown in [Table D.2.2.1](#). The other elevations of this *building* score lower because they are simpler.

D.2.2.2 The west elevation still has the *deck* connection and scores 7. *Cladding* options would be the same as for the south face.

D.2.2.3 The east elevation scores 6 and the north elevation scores 5, so these have more *cladding* options.

Examples using the risk matrix

Table D.2.2.1: Risk matrix example 2 for the south face of a moderately complex building

Paragraph [D.2.2.1](#)

Risk factor	Low risk		Medium risk		High risk		Very High risk		Subtotals for each risk factor ⁽¹⁾
	severity ⁽¹⁾	Score	Severity ⁽¹⁾	Score	severity ⁽¹⁾	Score	severity ⁽¹⁾	Score	
Wind zone (as per NZS 3604) ⁽¹⁾	0		0		1	1	2		1
Number of storeys	0		1	1	2		4		1
Roof/wall junction design	0		1		3		5	5	5
Eaves width	0		1		2	2	5		2
Envelope complexity	0		1	1	3		6		1
Deck design	0		2	2	4		6		2
Total risk score for use in Table 3.1.3.2									12

D.2.3 Cladding options

D.2.3.1 *Cladding* options for the south and west elevations from [Table 3.1.3.2](#) are:

a) *direct fixed claddings*:

- i) bevel-back timber weatherboards, and
- ii) vertical board and batten weatherboards, and
- iii) vertical corrugated metal; and

b) *Wall cladding* with a nominal 20 mm *drained cavity*:

- i) *masonry veneer* (with 40 mm cavity), and
- ii) *stucco*, and
- iii) horizontal profiled metal – corrugated and *trapezoidal* only, and
- iv) rusticated weatherboards, and
- v) fibre cement weatherboards, and
- vi) fibre cement sheet, and
- vii) plywood sheet, and
- viii) *EIFS*.

D.2.3.2 *Cladding* options for the north and east elevations from [Table 3.1.3.2](#) are:

a) *direct fixed claddings*:

- i) timber weatherboards – all types shown, and
- ii) fibre cement weatherboards, and
- iii) vertical profiled metal – corrugated and symmetrical *trapezoidal* only, and
- iv) fibre cement sheet, and
- v) plywood sheet, and
- vi) *EIFS*; and

Examples using the risk matrix

- b) Wall *cladding* with a nominal 20 mm *drained cavity*:
 - i) *masonry veneer* (with 40 mm cavity), and
 - ii) *stucco*, and
 - iii) horizontal profiled metal – corrugated and *trapezoidal* only.

D.3 Complex buildings – example 3

D.3.1 Description of the building

D.3.1.1 The third example illustrates the use of the *risk matrix* for a complex *building* as shown in [Figure D.3.1.1](#).

D.3.1.2 The combination of features present on the south elevation results in a very high *risk score*. The presence of a parapet at the roof, *decks*, enclosed *balustrade-to-wall* junctions and pergola connections all contribute to this risk. The site is in a High *wind zone*.

Figure D.3.1.1: Risk matrix example 3 for a complex building

Paragraph [D.3.1.1](#)

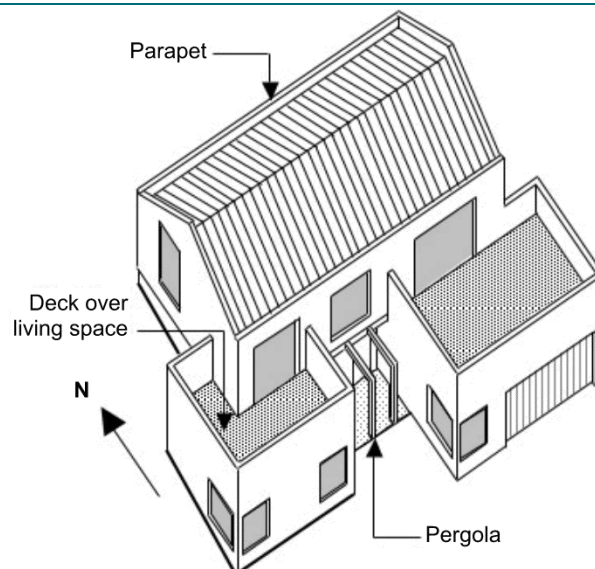

D.3.2 Calculation of the risk score

D.3.2.1 The risk score has been calculated for the south elevation in accordance with Paragraphs [3.1.2.1](#) and [3.1.3.1](#) and is shown in [Table D.3.2.1](#), is sufficiently high that the south elevation would require *specific design*, or redesign to lower the risk.

D.3.2.2 *Specific design* may result in the *building consent authority* possibly:

- a) needing more details to be provided; and
- b) requiring more inspections during construction; and
- c) requiring a third-party audit of the design.

D.3.2.3 The east and west elevations also score very highly at 18-20, and would require a *cladding* with a cavity such as vertical profiled steel, *masonry veneer* or any other *cladding* with a nominal 20 mm drained cavity.

D.3.2.4 The north elevation scores 14, so would require the use of the same *cladding* option as the east and west elevations.

Examples using the risk matrix

Table D.3.2.1: Risk matrix example 3 for the south face of a complex building

Paragraph [D.3.2.1](#)

Risk factor	Low risk		Medium risk		High risk		Very High risk		Subtotals for each risk factor ⁽¹⁾
	severity ⁽¹⁾	Score	Severity ⁽¹⁾	Score	severity ⁽¹⁾	Score	severity ⁽¹⁾	Score	
Wind zone (as per NZS 3604) ⁽¹⁾	0		0		1	1	2		1
Number of storeys	0		1	1	2		4		1
Roof/wall junction design	0		1		3		5	5	5
Eaves width	0		1		2		5	5	5
Envelope complexity	0		1		3		6	6	6
Deck design	0		2		4	4	6		4
Total risk score for use in Table 3.1.3.2									22

D.3.3 Cladding options

D.3.3.1 As the south face has a *risk score* over 20, it will require:

- a) redesigning the proposal to reduce the risk and reduce the *risk score*; or
- b) *specific design*.

D.3.3.2 As the other faces score from 14 to 20, *cladding options* from [Table 3.1.3.2](#) are:

- a) *direct fixed claddings*:
 - i) vertical corrugated metal; and
- b) *wall cladding system* with a nominal 20 mm *drained cavity*:
 - i) *masonry veneer* (with 40 mm cavity), and
 - ii) *stucco*, and
 - iii) horizontal profiled metal – corrugated and *trapezoidal* only, and
 - iv) rusticated weatherboards, and
 - v) fibre cement weatherboards, and
 - vi) fibre cement sheet, and
 - vii) plywood sheet, and
 - viii) *EIFS*, and
 - ix) bevel-back timber weatherboards.

BUILDING PERFORMANCE

CONTACT DETAILS PO Box 1473, Wellington 6140 | T 0800 242 243 | E info@building.govt.nz

For more information, visit building.govt.nz

ISBN (online) 978-1-991409-04-1

© Ministry of Business, Innovation and Employment 2025. You may use and reproduce this document for your personal use or for the purposes of your business provided you reproduce the document accurately and not in an inappropriate or misleading context. You may not distribute this document to others or reproduce it for sale or profit.

The Ministry of Business, Innovation and Employment owns or has licences to use all images and trademarks in this document. You must not use or reproduce images and trademarks featured in this document for any purpose (except as part of an accurate reproduction of this document) unless you first obtain the written permission of the Ministry of Business, Innovation and Employment.